

Use and Maintenance Manual

Rotating telehandlers

RTH

Deutz stage IIIA

Deutz stage V

Data regarding the manual

Code	99261_RTMD
Revision	C
Release date	12/2023

Reference regulatory framework

This Manual has been drafted in compliance with the main reference standards:

Machinery Directive 2006/42/EC;

Standard Family EN 1459 *“Rough-terrain trucks - Safety requirements and verification”*;

Standard UNI 10653 *“Technical documentation – Quality of product technical documentation”*;

Standard UNI 10893 *“Technical documentation of product – Instructions for use – Articulation and exposition of the content”*.

Translation of the original instructions for:

Vehicle model	Trade name	Engine	Emissions regulation	Nominal power	Road approval
RTH 5.18-D5/A	RTH 5.18	Deutz	Stage IIIA	55.4 kW	
RTH 5.18-D5/D	RTH 5.18	Deutz	Stage V	55.4 kW	
RTH 5.21-D/A-1	RTH 5.21	Deutz	Stage IIIA	100 kW	-
RTH 5.21-D/D-1	RTH 5.21	Deutz	Stage V	100 kW	-
RTH 5.23-D/A-1	RTH 5.23	Deutz	Stage IIIA	100 kW	-
RTH 5.23-D/D-1	RTH 5.23	Deutz	Stage V	100 kW	-
RTH 5.25-D/A-1	RTH 5.25	Deutz	Stage IIIA	100 kW	-
RTH 5.25-D/D-1	RTH 5.25	Deutz	Stage V	100 kW	-
RTH 6.22-D/A	RTH 6.22	Deutz	Stage IIIA	100 kW	-
RTH 6.22-D/D	RTH 6.22	Deutz	Stage V	100 kW	LGPP008A (**)
RTH 6.26-D/A	RTH 6.26	Deutz	Stage IIIA	100 kW	-
RTH 6.26-D/D	RTH 6.26	Deutz	Stage V	100 kW	LGPP008 (**)

**** Certification number only valid for Italy**

INDEX

Data regarding the manual	2	Sound power level	24
Reference regulatory framework	2	Vibration level	25
PREFACE	8	VEHICLE'S IDENTIFICATION ELEMENTS	26
Manufacturer's details	8	Vehicle plates and marking	26
Important safety information	8	Cab identification plate	26
Using the manual	9	Engine identification plate	26
People to whom this manual is addressed	9	Transmission pump identification plate	27
Symbols used	10	Service pump identification plate	27
Declaration of initial testing	10	Gear pump identification plate	27
Delivery of the vehicle	10	Transmission motor identification plate	27
Receipt of the vehicle	10	Axles identification plate	27
Assistance	10	TECHNICAL PRODUCT INFORMATION	28
How to request assistance	10	Glossary	28
Spare parts	10	Features of the vehicle	28
EC Declaration of Conformity	11	Optional accessories	29
Warranty	12	Interchangeable equipment	29
Recall campaigns for product defects	13	General description of the vehicle	30
GENERAL WARNINGS	14	Front/left side	30
Hazards and safety instructions	15	Rear/right side	31
Noise protection	15	Cab interior (plan view)	32
Danger of crushing	15	Cab interior (front view)	33
Prevention of cuts and crushing	15	Safety labels	34
Danger from hanging load	16	FEATURES OF THE VEHICLE	40
Danger of burns	16	Vehicle features and main safety devices	40
Danger of battery explosion	16	Vehicle cab	40
Electrocution hazard	16	Climbing on to or climbing down from the vehicle	40
Works near power lines	16	Door window	42
Accident prevention in case of thunderstorms with		Rear window	42
lightning	17	Emergency exit	42
Risk of slipping	17	Driver's seat	43
Risk of falling, tripping	17	Adjustments	43
Penetration of fluids	17	Armrests	44
Pressurised air and water	17	Joystick	44
Limiting the ejection of liquids	17	Right joystick	45
Braking system accumulators	18	Left joystick	45
Storage of hazardous liquids	18	Steering column	46
Information regarding AdBlue®	18	Light, window wiper, horn selector	46
Information regarding asbestos	19	Steering wheel	47
Cabin air conditioning system information	19	Pedals	47
USE OF THE VEHICLE	22	Control dashboard	48
Correct use	22	Vehicle ignition key	48
Before starting the vehicle	22	Safety system limit override key	48
Visual inspection	22	Key for radio control wiring override in aerial work	
Concomitant work phases	22	platform	48
Reasonably foreseeable misuse	23	Multifunctional manipulator;	48
Incorrect use	23	Service buttons	49
Safety devices	23	Levelling on wheels	49
Safety devices on the vehicle	24	Stabiliser controls	50
Roll-Over Protective Structure (ROPS), Falling Objects		Electric emergency pump button	50
Protective Structure (FOPS)	24	Parking brake engagement button	50
Sound pressure level	24	Automatic parking brake	51
		Hazard lights button	51

Red emergency stop button	51	Additional cab work lights	74
Double USB socket	51	Additional work lights on the telescopic boom (Optional).....	74
Multiple function display	52	Shear pin housing for interchangeable equipment	74
Drive page	53	Anchoring points.....	74
Graduated indicators.....	53	Tow hook	75
Levelling indicator	53	Quick-fit coupling for the equipment	75
Turret rotation indicator	53	“l” and “U” couplings.....	75
Anti-tipping system indicator	54	Secondary access ladder.....	76
List of warning lights and functions that can be selected in the Drive page	55	Turret rotation lock pin	76
Handling mode	60	OPERATING TECHNIQUES.....	77
Speed of movements	60	Before using the vehicle	77
Reset.....	60	Work area	77
Eco mode.....	60	Weather conditions	77
Radio control connection	60	Climatic conditions of use	78
Steering modes.....	60	Road circulation.....	80
Boom suspension	61	Parking the vehicle	80
Winter mode	61	Interchangeable equipment installation	80
Stabilizers page.....	61	Equipment confirmation.....	82
Setup function	62	Removing the equipment	82
Auto levelling.....	63	Hydraulic shear pin	82
Radio control connection	63	List of compatible accessories	83
Limits page	63	Approved equipment.....	83
Limitation of telescopic boom extension	63	Handling of loads	84
Setting the movement speed limits	64	Centre of gravity of the load	84
Load page	65	Picking up a load from the ground with fork attachment plate.....	84
Flow rate diagram in static view	65	Moving the centre of gravity	86
Flow rate diagram in dynamic side view	66	Visibility	86
Flow rate diagram in dynamic plan view.....	66	Traversing over sloping ground	86
Commands page.....	66	INFORMATION REGARDING TRANSPORT.....	88
Air-conditioning system	66	Shipping the vehicle	88
Auxiliary lighting system.....	67	Lifting the vehicle	88
Ancillary functions.....	67	Anchoring the vehicle for transportation.....	88
Radio control connection	67	Towing the vehicle.....	89
Hydraulic rotation lock	67	Mechanical brake release.....	90
Working mode.....	68	Manual positioning of the reverse gear in neutral	90
24V electrical output at boom head.....	68	How to tow a vehicle	91
Continuous hydraulic fluid	69	MAINTENANCE	92
Idle speed/engine control	69	General information	92
Start & STOP	69	Vehicle in maintenance position	92
Cooling fan rotation reversal.....	70	Tightening torques	92
Password Pages	70	Tyres	93
System Info page	70	Standard inflation pressures	93
Air vents	71	Inflation with air	93
Service compartments for the vehicle driver.....	71	Inflation with nitrogen.....	94
Safety keys container	71	Replacing the wheels.....	94
Vehicle radio.....	71	Washing	94
Reading light.....	72	Liquids, lubricants and spare parts.....	95
Sunshade	72	List of spare parts for routine maintenance.....	96
Radio control battery charger	72	Maintenance Schedule	97
Radio control housing (Optional)	72	Maintenance operations	98
External elements	73		
Work and emergency lights	73		
Rear view mirrors	73		
Headlights.....	73		
Tail lights (Optional)	73		

Safety information	98	AXLES.....	143
Battery disconnect switch	98	BRAKES	143
Maintenance operations under the telescopic boom ..	98	HYDRAULIC SYSTEM	144
Maintenance operations in areas not accessible from the ground.....	99	ELECTRICAL SYSTEM	144
Hydraulic hoses	99	MASSES	144
Differentials oil.....	99	PERFORMANCES.....	145
Wheel reduction gears oil	100	SOUND POWER	146
Transmission shaft	100	SOUND PRESSURE AND VIBRATIONS	146
Steering elements	100	REFERENCE INFORMATION.....	148
Axles	101	REGISTER OF CHANGE OF OWNERSHIP	150
Transmission belt	101		
Checking the belt tension	101		
Replacement	101		
Engine oil.....	102		
Checking the engine oil level.....	102		
Changing the engine oil.....	102		
Replacing the lubrication oil cartridge	102		
Fuel prefilter.....	103		
Fuel filter	103		
Bleed the fuel supply system	104		
AdBlue® filter	104		
Fuel tank.....	104		
Coolant.....	105		
Bleeding the cooling system	105		
Engine radiator.....	106		
Hydraulic fluid	106		
Hydraulic fluid filter	106		
Two-speed reduction gear oil	107		
Engine air filter	107		
Cab air filter.....	108		
Telescopic boom sliding blocks.....	108		
Telescopic boom pins.....	109		
Telescopic boom chains	110		
Adjustment.....	110		
Checking for wear	111		
Windscreen washer liquid tank.....	111		
Emergency hydraulic pump.....	112		
Turret rotation slewing ring gear	112		
Check slewing gear bearing wear every 500 hours....	113		
Batteries.....	113		
FUSE SECTION.....	115		
TROUBLESHOOTING	124		
Error and display messages.....	124		
Engine troubleshooting.....	126		
VEHICLE STORAGE	135		
Leaving the vehicle unused for long periods	135		
Leaving the vehicle unused for less than 12 months ..	135		
Leaving the vehicle unused for less than 36 months ..	135		
Reusing the vehicle	135		
Dismantling and disposal of the vehicle.....	136		
DIMENSIONS.....	138		
RTH 5.18 – RTH 5.21 – RTH 5.23 - RTH 5.25.....	138		
RTH 6.22 - RTH 6.26	140		
TECHNICAL DATA.....	142		
ENGINE: DEUTZ (STAGE IIIA / STAGE V)	142		
TRANSMISSION	143		

PREFACE

Manufacturer's details

Magni Telescopic Handlers S.r.l.

Via Magellano, 22

41013 Castelfranco Emilia (MO) – ITALY

Tel. +39 059 8031000

Fax. +39 059 8638012

www.magnith.com

Important safety information

Most accidents caused by the use, maintenance and repair of a vehicle are due to failure to observe the most elementary rules of safety and caution. An accident can often be avoided if the potential hazards to which one is exposed are known, and the required precautions are taken. Those working on the vehicle must take the utmost care, have suitable technical skills, knowledge and equipment for carrying out the various operations correctly.

Improper and/or incorrect use, maintenance or repair of these vehicles can lead to serious injury and also death of workers.

Use the vehicles and/or carry out maintenance or repairs on them only after having completely read and understood all the instructions in this use and maintenance Manual.

The precautions and warnings regarding safety are highlighted in this Manual and on the vehicle by means of the informative stickers. Failure to heed these warnings may result in serious injury or even death of the operator or other persons.

Magni Telescopic Handlers S.r.l. may not be able to foresee all the possible circumstances which can constitute a safety hazard. The warnings contained in this Manual or applied on the vehicle may not be considered as all-inclusive. When adopting procedures, equipment or methods not expressly recommended and when using equipment different to that permitted, it is the operator's responsibility to make sure work is carried out in accordance with the main safety and legal standards.

Moreover, it is necessary to ensure that the vehicles are not rendered hazardous by accidental damage or emergency maintenance carried out without authorisation.

Magni Telescopic Handlers S.r.l. reserves the right to make modifications to the vehicles, their accessories, calibration and other information disclosed at any time without prior notification.

Using the manual

This manual must be considered an integral part of the vehicle, and must accompany it throughout its working life from commissioning to final disposal.

Therefore, it must be stored inside the vehicle, in the space provided or where it will be kept safe from premature deterioration, so that it is always readily available for consultation and in the best possible condition.



If lost and/or damaged, contact the Manufacturer directly for replacement documentation, indicating the manual code or vehicle code/model shown on its identification plate.

This manual has been drawn up by the Manufacturer with the aim of providing all the information necessary for the operator to use the vehicle correctly and safely and carry out routine maintenance on it.

This Manual contains all the information necessary for the operator. The operator must use the vehicle for the purposes envisaged and identified in this manual. The information must be read carefully and its contents strictly applied. Failure to comply with this information can lead to risks to the health, safety and welfare of persons and result in damage to property.

The manual reflects the state-of-the-art at the time the product was placed on the market. The Manufacturer reserves the right to make changes, additions or improvements to the Manual, without however resulting in this publication being considered inadequate.

All changes to the documentation are made following a controlled process. The different revisions ensure traceability by associating the manual with the different versions of the product placed on the market.

If the vehicle is fitted with optional accessories, a use and maintenance manual for the following will be provided together with this manual:

- **interchangeable equipment (lifting accessories, fork carriage, platforms, etc.).**
- **special set-ups (elevating cab, electromagnetic braking device, additional heater, etc.)**

The use and maintenance manuals of the interchangeable equipment and special set-ups must be considered as an integral part of the manual; therefore they must be kept safe and consulted using the same methods and with the same care.

People to whom this manual is addressed

This manual is addressed to:

- *operator*: a person trained and instructed with a specific theoretical-practical course for the use of the vehicle and related equipment,
- *general maintenance technician*: a person trained to carry out ordinary maintenance work with basic knowledge of mechanics, electricity and hydraulics,
- *specialised maintenance technician*: a person trained and instructed to carry out ordinary and extraordinary maintenance work with specific in-depth knowledge of mechanics, electricity and hydraulics.

Symbols used

The symbols used in this Manual comply with standard UNI EN ISO 7010:2012.

Danger indications included in this manual are made easily identifiable by a “warning symbol” flanked by one or more “words of warning”; in addition, there is always a message, in written or illustrated form, underneath the symbol, illustrating the danger and techniques for avoiding it.

Parts of the text that are considerably important or specific operating procedures have been highlighted with the use of the following symbols:

NOTICE

BLUE – WITHOUT safety alert symbol

Used to indicate the presence of a potentially dangerous situation which, if not avoided, can cause damage to property.



CAUTION

YELLOW – WITH safety alert symbol

Used to indicate the presence of a potentially dangerous situation which, if not avoided, can cause minor or moderate injury.



WARNING

ORANGE – WITH safety alert symbol

Used to indicate the presence of a potentially dangerous situation which, if not avoided, can cause death or serious injury.



DANGER

RED – WITH safety alert symbol

Used to indicate the presence of an imminently dangerous situation which, if not avoided, can cause death or serious injury.

Declaration of initial testing

Magni Telescopic Handlers S.r.l. declares that each vehicle and interchangeable equipment manufactured in its factories, before being placed on the market, has been subjected to inspections and tests in order to certify its compliance with the EU directives to which it is subject.

Following successful testing, Magni Telescopic Handlers S.r.l. issues a CE certificate for each of its vehicles/interchangeable equipment, which must be kept by the owner of the latter for the purposes of legal obligations.

Delivery of the vehicle

Magni Telescopic Handlers S.r.l. delivers the vehicle in compliance with the relevant construction standards and legislation in force depending on the country of use.

All references to standards are referred to in the CE certificate delivered with the vehicle and this Use and Maintenance Manual.

Receipt of the vehicle

If there are any damage, defects or missing items upon receipt of the vehicle, please contact the Sales Department immediately:

Magni Telescopic Handlers S.r.l.
Via Magellano, 22
41013 Castelfranco Emilia (MO) – ITALY
Tel. +39 059 8031000
Fax. +39 059 8638012
www.magnith.com

Assistance

How to request assistance

For all requests for assistance, the customer must contact Magni Telescopic Handlers S.r.l. After-Sales Service or Sales network directly, indicating the data given on the vehicle identification plate and the type of problem encountered.

Spare parts

For any spare parts, the customer can contact Magni Telescopic Handlers S.r.l. After-Sales Service directly, indicating the vehicle model and its serial no., and order the necessary components and/or devices.

EC Declaration of Conformity

DICHIARAZIONE "CE" DI CONFORMITA'
secondo Direttiva 2006/42/CE, allegato II, parte 1, lettera A



Il sottoscritto Dott. Riccardo Magni, in qualità di Legale Rappresentante della Società,

MAGNI TELESCOPIC HANDLERS S.r.l
Via Magellano 22
41013 Castelfranco Emilia (MO), Italia

quale persona autorizzata a costituire e conservare il Fascicolo Tecnico,

DICHIARA

sotto la propria esclusiva responsabilità,
che la macchina:

Carrello elevatore telescopico rotativo

MODELLO: **RTH 6.22-D/D**
NUMERO DI SERIE: **XXXXXXXX**
ANNO DI FABBRICAZIONE: **XXXX**

è conforme alle disposizioni delle seguenti direttive e leggi:

2006/42/CE		
D.Lgs. 262/2002		
2005/88/CE		
2000/14/CE procedura applicata secondo allegato VI proc. 1		
Organismo notificato; ECO Certificazioni S.p.a. , via Mengolina 33; 48018 Faenza (RA) Italy		
Organismo notificato n° 0714		
Potenza netta installata	[kW]	100
Livello di potenza acustica misurata L_{WA}	[dB(A)]	104
Livello di potenza acustica garantita L_{WA}	[dB(A)]	106
2014/30/UE		
2014/53/UE		

- e altresì conforme alle seguenti norme armonizzate
EN 12895:2015+A1:2019 Carrelli industriali - Compatibilità elettromagnetica

MAGNI TELESCOPIC HANDLERS S.r.l
Dott. Riccardo Magni
Legale Rappresentante
Castelfranco Emilia (MO), Italia, XX/XX/XXXX

ce_IT_82072_00

Warranty

Magni Telescopic Handlers s.r.l. ensures that its new Products (vehicles, interchangeable equipment and spare parts), under normal use and operation, shall be free from defects in material or workmanship for a period of twenty-four (24) months or 2000 hours of operation (vehicles and interchangeable equipment), and twelve (12) months, for spare parts. Each such period shall commence on the date on which Magni Telescopic Handlers S.r.l. delivers the Product to the Buyer, if the Buyer is a distributor of Magni Telescopic Handlers S.r.l. and delivers the Product to the End User. Each such period shall commence on the date of delivery of the Product by the distributor to the End User, but never more than six (6) months from the date of delivery of the Product by Magni Telescopic Handlers to the distributor, through the Magni portal channel. Spare parts mounted on or in a Product under warranty repair will acquire the warranty of the Product itself. The above warranties shall be honoured provided that Magni Telescopic Handlers S.r.l. receives written notice of the defect within thirty (30) days of its discovery, and it is stipulated that the product is stored and operated within the nominal limits and normal use and in strict compliance with the Magni Telescopic Handlers operation and maintenance manual, and the defect does not result in any way from the intervention, inactivity or abuse of the purchaser or third parties. If it cannot be established that the conditions and the above are fulfilled, this warranty will not cover the alleged defect.

If requested by Magni Telescopic Handlers, the defective product shall be returned to Magni Telescopic Handlers, or other premises designated by Magni Telescopic Handlers, for inspection. Magni Telescopic Handlers reserves the right to review product maintenance procedures to determine whether the alleged defect is covered by this warranty. Inspection procedures are required on delivery to validate warranty and workmanship.

Under the terms of this warranty, the obligation and liability of Magni Telescopic Handlers are expressly limited - at the sole discretion of Magni Telescopic Handlers S.r.l. - to the repair or replacement with new or reproduced parts or components, in any part, which Magni Telescopic Handlers S.r.l. finds defective in material or manufacture. Spare parts will be supplied to the buyer in accordance with Magni Telescopic Handlers S.r.l.'s current warranty management procedures.

All products replaced under warranty become the property of Magni Telescopic Handlers S.r.l.

Accessories, assemblies and components included in the products, which are not manufactured by Magni Telescopic Handlers, are subject to the warranty of their respective manufacturers.

This warranty shall be deemed null and void if the parts (including worn parts) used or assembled to the product are not original Magni Telescopic Handlers S.r.l. or if the serial numbers have been altered, made illegible or removed with respect to Magni Telescopic Handlers products or if the product has been tampered with without Magni Telescopic Handlers' prior written consent.

MAGNI TELESCOPIC HANDLERS MAKES NO OTHER WARRANTIES, EXPRESSED OR IMPLIED, AND MAKES NO WARRANTIES OF MERCHANTABILITY OR FITNESS FOR ANY PARTICULAR PURPOSE WHATSOEVER.

No employee or representative is authorised to modify this warranty unless such modification is made in writing and signed by an authorised officer of Magni Telescopic Handlers.

This warranty is intended to be continuous for the specified periods. Magni Telescopic Handlers does not accept interruptions and resumptions of such periods ("stop-and-go").

Magni Telescopic Handlers S.r.l.'s obligation under this warranty does not include the items listed below under "This warranty does not cover".

NON-TRANSFERABILITY OF THIS WARRANTY: This warranty is limited to the buyer or, where the purchase is made from a Magni Telescopic Handlers distributor, to the first end-user using the product, and is not assignable or otherwise transferable without the prior written consent of Magni Telescopic Handlers.

THIS WARRANTY DOES NOT COVER:

- normal maintenance, repair, spare or worn parts, including without limitation bearings, seals, couplings, hoses, clutch plates, glass, clutch and brake linings, filters, rope, outer covering, proper sealing of bolts, nuts and fittings, addition or replacement of fluids, filters, vents, belts, nozzles, adjustments of any kind, supplies and services offered, such as hand cleansers, wipes and lubricants, inspections, travel time;
- products sold by any person, company, collaborator or any other third party who is not authorised to distribute the product by Magni Telescopic Handlers;



- damage or defects, or any related costs, resulting from work performed by personnel not authorised to service and repair the product by Magni Telescopic Handlers;
- damage or defects caused by the use of the product by personnel or operators not authorised, instructed or trained in the use of the product;
- damage or defects resulting from inappropriate storage, exposure to external agents, non-use, use in an environment with the presence of chemical or corrosive agents;
- damage or defects caused by using the product in extreme geographical or weather conditions without the prior written consent of Magni Telescopic Handlers;
- damage or defects caused by non-compliance with Magni Telescopic Handlers' campaign bulletins, product safety and service announcements.

THIS WARRANTY EXPRESSLY SUPERSEDES AND EXCLUDES ALL OTHER WARRANTIES, REPRESENTATIONS AND CONDITIONS, EXPRESS OR IMPLIED, AND ALL OTHER LEGAL, CONTRACTUAL, NON-CONTRACTUAL AND COMMON LAW OBLIGATIONS OR LIABILITIES ON THE PART OF MAGNI TELESCOPIC HANDLERS S.R.L., WHICH ARE HEREBY EXPRESSLY EXCLUDED TO THE FULLEST EXTENT PERMITTED BY LAW.

IN THE EVENT OF ANY BREACH OF WARRANTY BY MAGNI TELESCOPIC HANDLERS, ITS LIABILITY SHALL BE LIMITED EXCLUSIVELY TO THE REMEDIES OF REPAIR OR REPLACEMENT OF ANY DEFECTIVE PRODUCT COVERED BY THE WARRANTY. EXCEPT AS OTHERWISE CONTAINED IN THIS WARRANTY, MAGNI TELESCOPIC HANDLERS DISCLAIMS ALL LIABILITY AND SPECIFICALLY EXCLUDES ANY INDIRECT, CONSEQUENTIAL, INCIDENTAL OR ANY OTHER DAMAGES OR LOSSES WHETHER OR NOT ADVISED OF.

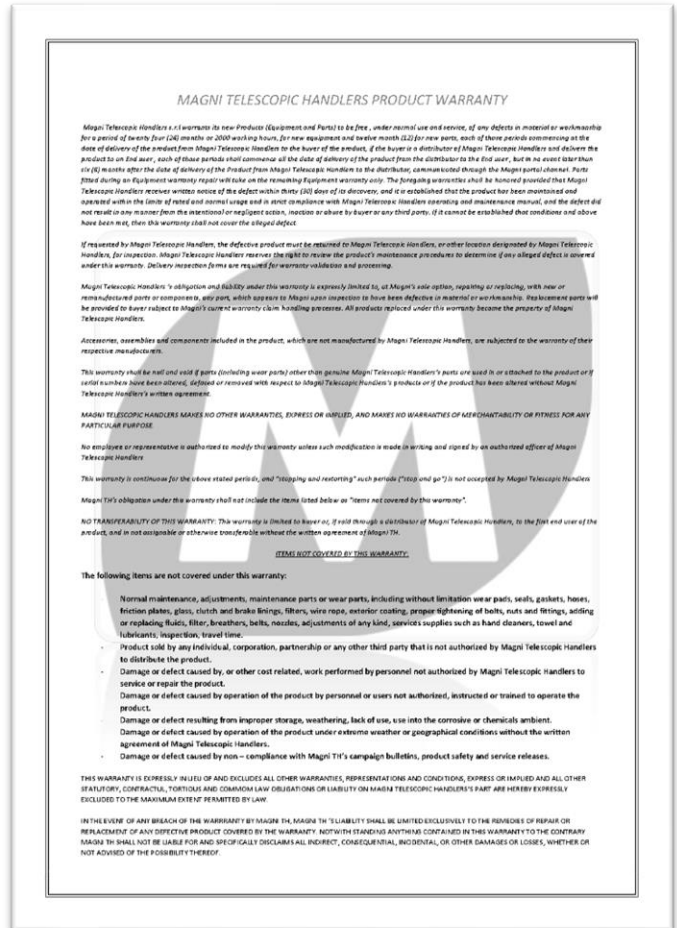

Recall campaigns for product defects

Magni Telescopic Handlers S.r.l., only after ascertaining the nature of the defect found, shall agree with its dealers, resellers and authorised workshops on the method and time of intervention (repair, replacement, modification).

Any work carried out without authorisation, communication sent to/received from Magni Telescopic Handlers S.r.l. or in full autonomy, shall invalidate the warranty on the modified/replaced element and on directly related parts that could be affected by poorly performed work.

GENERAL WARNINGS

NOTICE

Read this manual before using the vehicles covered in it



WARNING

Vehicles may only be operated and/or repaired by qualified and properly trained and instructed personnel.



DANGER



It is strictly forbidden to use the vehicle in an enclosed area with an explosive atmosphere or where vapours, gases or dusts are created that could make it potentially explosive (as described above), as this telescopic handler does not comply with ATEX ("ATmosphere EXplosive") regulations.



DANGER

All uses of the vehicles and operating procedures not described in this manual are prohibited.

It is strictly forbidden to use the vehicles and their applications otherwise than in accordance with this manual and the nature for which they were designed.



WARNING

Check the condition of the vehicle and interchangeable equipment in use on a daily basis before using them: safety devices, oil leaks, condition of service and safety stickers present.

If there are anomalies and/or damage, make the necessary corrections.

- Do not use the vehicles with wet hands and/or shoes, grease or oil on them.
- If the operator is new to the vehicle, he/she must become familiar with it before using and manoeuvring it in an open area to learn its dimensions as well as the controls and their position.

- Use all appropriate precautions when driving the vehicle:
 - verification of the work area;
 - verification of the weather conditions;
 - signal the movement of the vehicle with an acoustic and light signal;
 - always keep a safe distance from people or things.
- Carefully read the Use and Maintenance Manual of the equipment you intend to use with the vehicle in order to know its specific uses and warnings.



DANGER

Do not operate under the influence of medicinal, alcoholic or narcotic substances that may impair the driver's reflexes.



DANGER

Do not smoke or light naked flames under any circumstances whatsoever. Naked flames in contact with fuel, oil or solvents present on the vehicle or necessary for its maintenance can cause injuries, even fatal.

Inhalation of gases produced by a flame or contact with coolant gas can cause injury to the respiratory airways, even fatal.



DANGER



Do not stand or walk near moving operating vehicles.



DANGER



Do not carry passengers on the vehicle and any equipment connected to it.



DANGER

Do not carry passengers on the vehicle and any equipment connected to it.

Hazards and safety instructions

The persons involved in the operational phases on the construction site must become aware of the potential risks present and the safety measures to be followed.

Appropriate accident-prevention clothing and equipment specific to each type of work must be worn.



CAUTION

Keep Personal Protective Equipment (PPE) in good condition.

Accident-prevention clothing and equipment must always be in good condition and the right size to perform the assigned task.

Replace immediately in case of damage or incorrect sizes before starting or continuing operations.



In order to carry out site activities correctly, always wear:

- protective footwear with anti-crush toe cap and anti-puncture sole,
- protective gloves,
- appropriate clothing,
- high visibility clothing,
- protective goggles,
- protective helmet for falling objects.

NOTICE

In view of the several processing steps that can occur, be aware in advance of the activities to be performed in order to have the required equipment when needed.

Noise protection



WARNING



Wear hearing protection devices (headphones or earplugs) to protect yourself from excessive and annoying noise.

Prolonged exposure to loud noises can lead to hearing damage or loss.

Danger of crushing.



DANGER



Pay attention to mobile and/or moving parts to avoid crushing or dragging.

Prevention of cuts and crushing

Support the equipment adequately before carrying out any kind of work on it. Do not rely on hydraulic jacks for supporting the equipment: these may fall if a pipe breaks or in case of involuntary activation.

Do not try to make any adjustment while the vehicle is in motion or with the engine switched on, unless otherwise specified.

Avoid tampering with the electrical system of the vehicle to try starting the engine. This may cause involuntary movements of the equipment.

Keep at a safe distance while operating the equipment using the control levers. Increase the safety distance if there is a possibility of the moving parts making rapid and sudden movements.

If it is necessary to remove the safety devices fitted on the vehicle to carry out maintenance or repairs, always refit these at the end of operations.

Keep limbs away from the moving fan blades. The fast moving blades are comparable to sharp blades, and can cause serious tears.

Keep small objects away from the moving fan blades. The blades may throw off these objects at high speed, making it dangerous for the safety of persons.

Do not use frayed or bent steel cables. Always wear protective gloves while handling steel cables.

If a pin is tapped with great force, it may come out of its seat suddenly. A pin thrown off with force can cause serious injuries to persons in the vicinity. If tapping on a pin, make sure there is no one in the surrounding area.



WARNING

When removing pins, ensure that you have secured the parts in question to prevent them from falling accidentally and causing damage and injury to property and persons.

Danger from hanging load



DANGER



Pay attention to suspended loads, danger of falling material. Do not approach people when using the vehicle; keep a safe distance.

Danger of burns



DANGER



Do not touch the engine or any components directly connected to it during operation. Allow the engine to cool down before carrying out any maintenance. Before disconnecting any component of the hydraulic or pneumatic circuits, make sure all the residual pressure has been discharged from the circuit.

After operation, the engine coolant is hot and under pressure. Contact with hot water or steam leaks can cause severe burns.

Avoid possible injuries caused by hot water jets. Do not remove the radiator cap until the engine has cooled down. To open, unscrew the cap until it stops. Before removing the cap, discharge all of the pressure.

The oil in the engine, gearboxes and hydraulic system heats up during vehicle operation. The engine, rigid and flexible hoses and other components heat up.

Wait for the components to cool down before starting maintenance or repairs.

Avoid these hazards while repairing or carrying out maintenance on the vehicle by discharging the pressure (with the hydraulic levers on the control valves) before disconnecting or repairing hoses and hydraulic parts.

Before restarting the engine make sure that all fittings are tightened correctly.

Look for any leaks with a piece of cardboard; make sure that your hands and body are protected against pressurised fluids. Protect your eyes with a face shield or safety goggles.

If an accident occurs, immediately seek medical attention. Any fluid injected under the skin must be surgically removed within a few hours to avoid infection.

Danger of battery explosion



DANGER



Keep away from battery poles, sparks, open flames and/or cigarettes.

Do not overturn or tilt the battery to prevent acid leakage.

Do not generate sparks when connecting batteries when charging or connecting with other batteries.

Do not charge batteries at extreme temperatures (too hot or cold) or if they are damaged: they may burst.

When servicing batteries, always wear protective gloves and goggles.

Electrocution hazard



DANGER



All maintenance work and/or adjustments to be performed on live parts must only be carried out by qualified and suitably trained personnel.

Works near power lines

In the case of work to be performed in the presence of power lines, check in advance the availability of adequate safe manoeuvring space.



DANGER



When working close to power lines, maintain the distances specified below:

Voltage (kV)	Distance (m)
≤ 1	3
1 < Un ≤ 30	3.5
30 < Un ≤ 132	5
> 132	7

Source Italian Legislative Decree No. 81/08 Annex IX for ITALY.

For work close to unprotected power lines performed outside Italy, refer to the local regulations.

**WARNING**

If it is necessary to work close to power lines, organise the work with an operator on the ground who, at a safe distance, can supervise the vehicle's movements and inform the operator in the cab about excessive proximity to power cables.

The vehicle operators must equip themselves with rubber shoes and gloves, cover the vehicle seat with a rubber cover and take care not to touch any part of the chassis with unprotected body parts.

**DANGER**

In the event of contact of power lines with the vehicle, the operator inside the vehicle must remain inside waiting for the power supply to be interrupted.

Accident prevention in case of thunderstorms with lightning**DANGER**

During a thunderstorm with lightning, the operator must move away from the vehicle and keep at a safe distance.

Never try to climb on or get down from the vehicle if lightning strikes in the vicinity. The operator in the cab must stay inside until the thunderstorm and lightning is over.

Risk of slipping**DANGER**

During operations carried out on site, the areas around the equipment can contain various kinds of debris and liquids (oil, water, etc.) that can make the ground slippery. Be extremely careful.

Risk of falling, tripping**DANGER**

Be extremely careful when climbing up and down the vehicle.

Penetration of fluids**DANGER**

Pressurised fluids such as fuel or hydraulic fluid can penetrate the skin or eyes, causing serious injury.

The pressure values in the hydraulic circuit may remain high for a long time even after the vehicle is switched off. If not discharged properly, the pressure can cause violent ejection of oil and objects.

Do not disconnect or dismantle any of the hydraulic components if the pressure has not been discharged correctly, as this can lead to serious accidents.

Refer to the maintenance section of this Manual for the methods for discharging the hydraulic pressure correctly.

Pressurised air and water**DANGER**

Pressurised water can cause injury to tissues, especially if accompanied by debris. Compressed air can cause injuries.

If water or compressed air is used for cleaning operations, wear suitable protective equipment, in particular for sensitive organs like the eyes.

NOTICE

The maximum air pressure for cleaning must be less than 2 bar. The maximum water pressure must be less than 3 bar.

Limiting the ejection of liquids**CAUTION**

It is necessary to deal with the leakage of liquids during the operations carried out on the vehicle. Provide suitable containers for collecting the liquids before acting on any component of the vehicle containing fluids.

Dispose of the liquids used in compliance with the regulatory standards in force in the country in which the vehicle will be used.

Braking system accumulators



DANGER



Take utmost care while performing maintenance on the pressurised accumulators.

In order to remove the accumulators safely, switch off the vehicle and then pump the brake pedal about 35 to 40 times.

Once this has been done, and wearing appropriate PPE (overalls, goggles, gloves), carefully wrap an absorbent cloth around the accumulator coupling and start gently unscrewing it, allowing the oil to slowly bleed out until it runs dry.

When the pressure has been fully discharged, remove the accumulator and replace it.

Storage of hazardous liquids



DANGER



All fuels, most lubricants and some antifreeze liquids are flammable; handle them with care to avoid fire and potential explosion.



WARNING

Keep flammable products away from persons not competent and authorised to handle them.



WARNING

Under no circumstances should substances of a different type be mixed.



DANGER



Due to the toxicity of the chemicals, avoid contact with skin and eyes by wearing suitable PPE.

Information regarding AdBlue®

AdBlue® is a water-soluble non-flammable, non-toxic, colourless, odourless liquid. It may be referred to as “urea” or “DEF” (Diesel Exhaust Fluid).

If AdBlue® comes in contact with painted surfaces or aluminium, wash the areas concerned immediately with water.



CAUTION

Do not mix AdBlue® with any additive. Mixing additives with AdBlue® can cause serious faults in the system for post-treatment of exhaust gases.

Any impurity present in AdBlue® can cause malfunctioning of the engine and of the exhaust gases post treatment system. Make sure the AdBlue® is free of impurities. Do not reuse the AdBlue extracted from the system.



This sign is positioned near the AdBlue® tank connector.

AdBlue® and high temperatures

The chemical composition of AdBlue® can change if exposed to temperatures exceeding 50°C (122°F), releasing ammonia vapours.



WARNING

Ammonia vapours are highly toxic and corrosive. Ammonia vapours have a pungent smell, and irritate:

The skin;
The airways;
The eyes.

Do not open the AdBlue tank or any part of its supply circuit while the liquid is hot.

Strictly avoid inhaling ammonia vapours or contact with the eyes and skin.

In case of contact with any part of the body, rinse immediately with water for at least 15 minutes and see a doctor immediately.

AdBlue® and low temperatures

AdBlue® freezes at temperatures below -11°C (12.2°F). However, it is possible to use the vehicle below -11°C (12.2°F). AdBlue® crystals are mainly formed in the lines between the engine and silencer. Wash with water to remove these crystals.

Storage and disposal

To store AdBlue®, use only containers made of one or more of the following materials:

Cr-Ni steel according to standard
DIN EN 10088--1 /2 /3;

Mo-Cr-Ni steel according to standard DIN EN 10088-1
/2 /3;

Polypropylene;
Polyethylene.

Do not use containers made of the following materials:

Aluminium;
Copper;
Copper alloys;
Non-alloy carbon steels;
Galvanised steels.

AdBlue® can corrode these materials and cause severe damage to the exhaust gases post-treatment system.

Dispose of AdBlue® in accordance with the standards in force in the country in which the vehicle is used.

NOTICE

For engines satisfying the Stage V anti-pollution standards, in order to protect the AdBlue® purification system, wait at least 5 minutes after the I.C. engine is switched off, before acting on the main electric circuit to disconnect it.

Information regarding asbestos

Magni Telescopic Handlers S.r.l. products and spare parts are asbestos-free. Using non genuine spare parts can lead to risk of handling products containing asbestos.

Avoid inhaling dusts which may be produced when handling components containing asbestos fibres. Inhaling these dusts can be harmful for health. The non original components which may contain asbestos are the friction elements of the brakes and clutches, linings and types of gaskets. The asbestos used in these components is generally immersed in resin or sealed in another manner. Normal handling is not hazardous as long as suspended dusts are not produced.



DANGER

If dusts containing asbestos are present, the following precautions must be taken:

Do not use compressed air for cleaning;

Avoid brushing materials containing asbestos;

Avoid grinding materials containing asbestos;

Use wet cleaning methods for parts containing asbestos;

Equip the work area with appropriate air extractors;

If there are no other methods for controlling the dusts, wear a suitable respiratory mask;

Avoid areas where asbestos particles may be present in the air.

Cabin air conditioning system information

The machines built by Magni Telescopic Handlers S.r.l. equipped with an air conditioning system, use R-134a type gas in compliance with point 15 of Annex III of European Regulation no. 517/2014.



Declaration of conformity with Article 14 of Regulation (EU) No 517/2014 of the European Parliament and of the Council

We MAGNI TELESCOPIC HANDLERS S.r.l, VAT NUMBER 03353620366, declare under our sole responsibility that when placing on the market pre-charged equipment, which we manufacture in the Union, the hydrofluorocarbons contained in that equipment are accounted for within the quota system referred to in Chapter IV of Regulation (EU) No 517/2014 as:

✓	C. The hydrofluorocarbons charged into the equipment were placed on the market by a producer or importer of hydrofluorocarbons subject to Article 15 of Regulation (EU) No 517/2014.
	B. The hydrofluorocarbons contained in the equipment have been placed on the market in the Union, subsequently exported and charged into the equipment outside the Union, and the undertaking that placed the hydrofluorocarbons on the market made a declaration stating that the quantity of hydrofluorocarbons has been or will be reported as placed on the market in the Union and that it has not been and will not be reported as direct supply for export in the meaning of Article 15(2)(c) of Regulation (EU) No 517/2014 pursuant to Article 19 of Regulation (EU) No 517/2014 and Section 5C of the Annex to Commission Implementing Regulation (EU) No 1191/2014 (2).
	A. We hold authorisation(s) issued in accordance with Article 18(2) of Regulation (EU) No 517/2014 and registered in the registry referred to in Article 17 of that Regulation, at the time of release for free circulation to use the quota of a producer or importer of hydrofluorocarbons subject to Article 15 of Regulation (EU) No 517/2014 that cover(s) the quantity of hydrofluorocarbons contained in the equipment.

MAGNI TELESCOPIC HANDLERS
Mr. Riccardo Magni
 LEGAL REPRESENTATIVE

MAGNI TELESCOPIC HANDLERS SRL
 Via Magellano, 22 - Loc. Cavazzona
 41013 Castelfranco Emilia (MO)
 C.F. / P. IVA 03353620366
 Tel. 059.8031000 - Fax 059.8638012

Castelfranco Emilia
 ITALY
 11/10/2023

Magni Telescopic Handlers Srl

Via Magellano, 22 - 41013 Castelfranco Emilia (MO) - ITALY
 Tel. +39 059 8031000 • Fax +39 059 8638012 • P. IVA/C.F. IT03353620366 • SDI: R7Y4CEC • Capitale Sociale 1.262.500 Euro i.v.
www.magnith.com

USE OF THE VEHICLE

Correct use

NOTICE

Read this manual before using the vehicles covered in it.

Be aware of all the dangers and warnings described here.

The telescopic handler is a vehicle designed for lifting material (and people with an aerial work platform) that can cause serious damage to the operator(s) and the environment if not used as intended.

Therefore, this vehicle **MUST** only be used for the purposes given in this use and maintenance manual.

Observance of the use, maintenance and repair instructions in this document are essential parts of the intended use.



WARNING

The vehicle **MUST** only be used by trained and qualified personnel who are aware of and follow the instructions given in this use and maintenance manual.

In some countries, it is compulsory for personnel using slewing variable-reach trucks to attend courses in order to obtain a licence.

Before starting the vehicle

Visual inspection

To ensure the maximum useful operating life of the vehicle, and maximum efficiency of and in the operating phases, proceed with a thorough visual inspection before every start-up of the vehicle and the working area.

Look around and under the vehicle, checking to make sure there are no loose or missing bolts, no accumulated dirt, leakage of oil, fuel and other liquids, broken or worn parts.

Check the state of the equipment and hydraulic components.

Check the state and wear of the tyres. If necessary, adjust the inflation pressure.

Check the tightness of the wheel bolts.

Check the levels of the oil, coolant and fluid.

Check the AdBlue® tank level (if present).

Take a view of the work area, check for any obstacles and assess their extent and the best approach to the operational phases.

Clean the windows, headlamp glass and rear-view mirrors.

Adjust the orientation of the rear-view mirrors to best cover the visual area around the vehicle.

Remove dirt residues from the engine, radiator and the various joints on the vehicle (steering hubs, swing jack, telescopic boom hinges, etc.)

Clean and ensure that steps and grab handles in the cab are dry.

Check the integrity and legibility of all safety and information stickers: replace if not in good conditions.

Check the correct functioning of all joints.

Check under the vehicle for oil, fuel or coolant leaks.

Make sure all the hoods are closed and all guards are installed correctly on the vehicle.



WARNING

It is forbidden to start work with the vehicle or equipment not in perfect condition.



WARNING

Carry out repairs or resetting if necessary.

Concomitant work phases

In the presence of other operating vehicles in the same work area, call a meeting to organise the operational phases.

Assess the presence of a suitably trained signalman to coordinate manoeuvres in the vicinity of several vehicles.

Ensure that the operators in the cab are familiar with the indications given by the signalman on the ground.

Reasonably foreseeable misuse

During daily work, it can happen that the vehicle may be used incorrectly or the instructions in this manual may not be followed.



CAUTION

Experience has taught us that there may be some indications of reasonably foreseeable misuse of the slewing variable-reach truck.

The various type of slewing variable-reach truck misuse are strictly forbidden by the manufacturer.

Below is a list of reasonably foreseeable, potentially dangerous situations of misuse:

- the accidental loss of control of the vehicle by the operator;
- the behaviour resulting from a lack of concentration or carelessness by the operator, which does not stem from a desire to misuse the vehicle;
- operating the vehicle on sloping ground without following the guidelines described in the relevant section of this manual;
- the instinctive, unforeseeable reaction of an operator in the event of a malfunction, accident or breakdown while using the vehicle;
- the operator using the vehicle with the feeling that the protection devices are only a hindrance to the operations to be carried out;
- the behaviour resulting from the adoption of the "law of least effort" while carrying out a task with the vehicle;
- the behaviour resulting from external pressure on the operator to keep the vehicle in operation under all circumstances, even potentially dangerous ones;
- the predictable behaviour of certain categories of people such as: adolescents, trainees, apprentices, disabled people, etc.;
- operators tempted to use the vehicle for a bet, for competitions, etc.



WARNING

It is absolutely forbidden to carry passengers other than the driver in the vehicle: they may obstruct the view and hinder the driving manoeuvres of the regularly seated operator.



WARNING

It is absolutely forbidden to transport people in the presence of a passenger platform, even if it is regularly coupled and certified.

The platform may only be used when the vehicle is properly stabilised and the parking brake is applied.

Incorrect use



WARNING

It is strictly forbidden to use the vehicles without adequate knowledge of them.



WARNING

It is strictly forbidden to use the vehicle as a ram to demolish structures: Magni Telescopic Handlers are not designed to withstand and support such stresses.



WARNING

It is strictly forbidden to lift material and persons without the use of specific interchangeable equipment: it is forbidden to tie straps directly onto the telescopic boom or quick-fit coupling.



WARNING

It is absolutely forbidden to carry passengers other than the driver in the vehicle: they may obstruct the view and hinder the driving manoeuvres of the regularly seated operator.

Safety devices

Before using the vehicle, ensure that all safety devices are visible and working properly.

Should you find any anomalies in the safety devices, stop working until the fault has been repaired (Contact your dealer or Magni Telescopic Handlers S.r.l. Support Service).

Check that the symbols and safety stickers are clearly legible.

For your own safety and that of others, do not disable or alter operation of the safety devices.



WARNING

When using equipment with electrical or hydraulic connections, these must always be connected properly to the vehicle with the respective connectors.

Failure to connect them stops the safety devices from working correctly, with a risk of damage to property and people and a risk of overturning the vehicle.

The main checks for the equipment safety devices are recommended by the manufacturer with time schedules and must be indicated on the Inspection Register attached to this manual or in the manual of the equipment itself.

These checks ensure that the safety devices work correctly.

Safety devices on the vehicle

Below is a list of the main safety devices on the vehicle:

- ROPS-FOPS certified cab
- Emergency light^[SEP] (red beacon on top of the cab)
- Emergency stop button in the cab
- Safety symbols and stickers on the vehicle
- Driver's seat microswitch^[SEP] (operator seated correctly)
- Dead Man's Joystick Button^[SEP] (manoeuvre enabling button)
- Seat belt, driver's seat
- Emergency exit^[SEP] (door side glass and back window in cab)
- Parking brake button **(P)**;
- Hazard lights button
- Electric emergency pump
- Quick-fit coupling shear pin^[SEP] (manual or hydraulic)
- Work area Control System
- Load Control System (LMI)
- Fire extinguishers (depending on equipment)

A detailed description of the safety devices listed can be found in the relevant sections of this manual.

Roll-Over Protective Structure (ROPS), Falling Objects Protective Structure (FOPS)

The cab structure is designed, tested and certified (Level II) ROPS/FOPS. The certification label is applied in the upper part inside the cab.



WARNING

Any alteration of the structure can weaken and put the operator at risk.

The protection offered by ROPS/FOPS structures will be affected in case of structural damage.

Avoid structural repair or modification of the ROPS/FOPS structure. These operations will make the structure different from the original, and cause invalidation of the certification.

Sound pressure level

The sound pressure level perceived by the operator inside the cab is less than 80dB. This level was measured on a standard vehicle. The measuring procedure used is described in detail in the following standards:

EN 12053

ISO 11201

Sound power level

The level of acoustic power emitted (guaranteed) is indicated inside the cab for each model according to the applied engine. The measurement was carried out according to Directive 2000/14/EC subsequently modified by Directive 2005/88/EC.

Vibration level

Hands and arms are subjected to an average weighted acceleration level less than 5 m/s^2 .

The entire body is subjected to an average weighted acceleration level less than 1 m/s^2 .

These levels are measured on a standard vehicle. The measuring procedure used is described in detail in the following standards:

ISO 2631-1:2014

UNI EN ISO 5349-1:2004

UNI EN 13059:2008

VEHICLE'S IDENTIFICATION ELEMENTS

Vehicle plates and marking

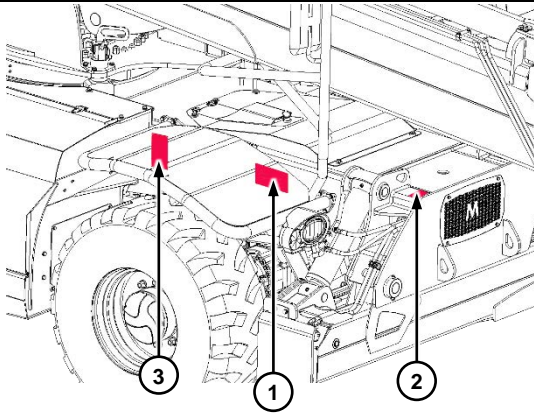

- ① Manufacturer's plate with vehicle identification data, located under the right front mudguard



- ② Serial code marking on the upper right-hand portion of the chassis.



- ③ Road traffic certification plate, located under the right front mudguard.



Cab identification plate

The cab identification plate is affixed on the upper crossbar, to the left of the driver.

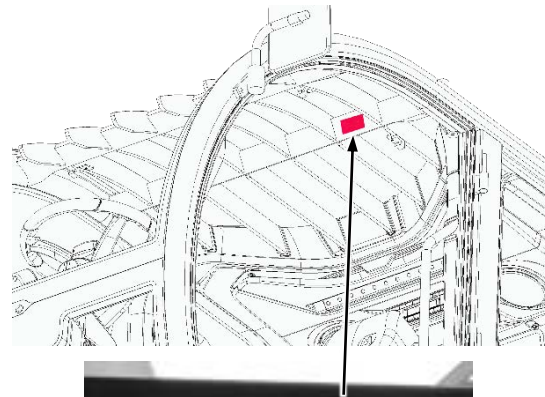

Engine identification plate



The engine identification plate is applied on the upper part of the cover.

Transmission pump identification plate

The transmission pump plate is affixed at the bottom of it, inside the engine compartment, as shown above.

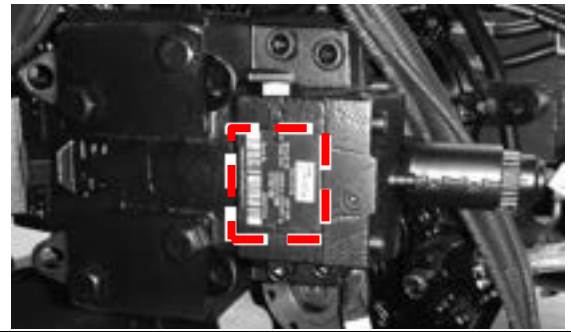
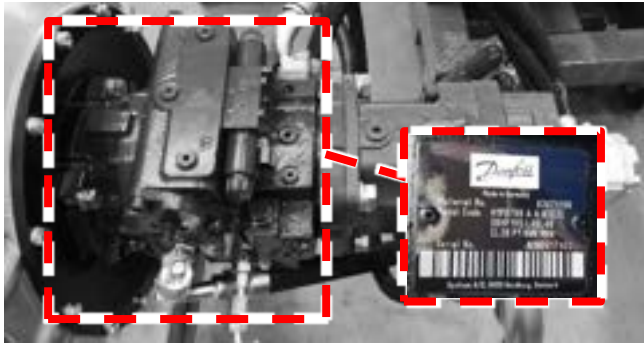

Axles identification plate

The axles (front and rear) identification plate is affixed on the top of the differential.



Service pump identification plate

The service pump identification plate is affixed to the pump inside the engine compartment, as shown above.

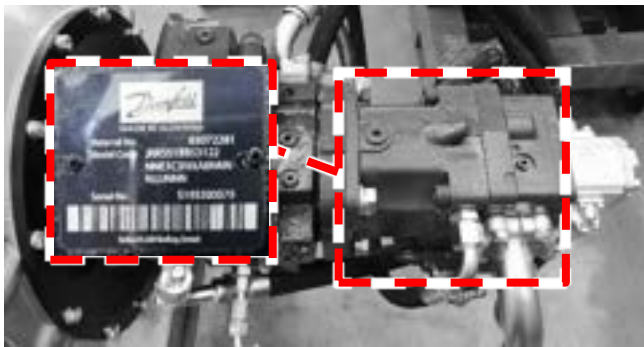

WARNING

Do not remove/damage the plates on the vehicle and its components. The absence of a plate can have an impact on the correct identification of the vehicle/components with consequences in terms of:

- warranty
- certification
- safety

Gear pump identification plate

The gear pump identification plate is affixed to the pump inside the engine compartment, as shown above.



Transmission motor identification plate

The transmission motor plate is affixed to the motor on the bottom right hand side of the vehicle. To access it, lie down under the vehicle between the two axles near the right front wheel.

TECHNICAL PRODUCT INFORMATION

Glossary

Front:

area in front of the operator correctly seated in the cab while the vehicle is moving forward.

Rear:

side behind the operator correctly seated in the cab while the vehicle is moving forward.

RH side:

side to the right of the operator correctly seated in the cab while the vehicle is moving forward.

LH side:

side to the left of the operator correctly seated in the cab while the vehicle is moving forward.

Operating machine / vehicle / telehandler:

self-propelled vehicle intended for operation on roads or construction sites equipped with special interchangeable equipment.

Interchangeable equipment:

device which, when assembled with the operating machine, allows the latter a specific functionality.

Features of the vehicle

The telehandler model is equipped with the following standard elements:

- 4-wheel drive and steering of equal size
- Limited slip differential on axle
- Swing lock on rear axle
- Steering alignment indicator
- 4 independent stabilisers with electronic position controls
- Telescopic boom with multiple extensions, hinged to rotating turret
- Anti-tilt device with block for dangerous movements
- Easy selection of interchangeable equipment
- Telescopic boom limit switch
- Two-way hydraulic supply at the boom end
- Two-speed operation
- Road lights
- Work lights
- Airtight driver's cab with heating, demisting, ventilation and air conditioning, soundproofed and ROPS / FOPS certified
- Front, rear and top window wipers
- Adjustable seat
- Adjustable steering wheel
- Service alarms
- Digital display
- Working area limit control
- Joystick for hydraulic controls
- Hydraulic movements with proportional control valve
- Radio with CD player
- Lockable fuel cap

Optional accessories

Below is a list of accessories available for your vehicle model that can be installed at the time of your order or later by contacting your local dealer (if the vehicle is properly preset):

- Cameras with in-cab monitor for perimeter view
- Standard radio control
- Radio control for "aerial platform driving" kit
- Complete tow hook
- Rear 24V electric plug for trailer (7 pin/13 pin)
- Double hydraulic output at the boom head
- Triple hydraulic output at the boom head
- Engine coolant heater (110V/230V)
- Hydraulic fluid heater (24V)
- Hydraulic fluid heater (110V/230V)
- Complete right spare wheel
- Complete left spare wheel
- Road use (subject to country-specific certification)
- Boom suspension
- Air-suspension driver's seat
- 24V heated driver's seat
- Heated rear view mirrors (24V)
- DAB Radio
- 110/220 Volt plug at boom end
- Pair of LED headlights on the top-front of the cab
- Pair of LED headlights on the top-rear of the cab
- Pair of LED boom lights
- Complete toolbox
- Nordic climate package
- Oversized stabiliser mobile support bases and associated chassis support
- Hydraulic equipment lock at the telescopic boom end
- Hydraulic blocking of turret rotation
- Hydraulic fluid for cold climate
- Bio hydraulic fluid
- Setup for the Twin Power kit
- Switching off the external battery
- Ladder and chassis supports
- Protective grilles for cab windows
- Wheel chocks

NOTICE

The list of optional accessories is subject to change without notice.

Interchangeable equipment

- Fork attachment plate
- Lifting hook
- Lattice-encased boom with lifting hook
- Hydraulic winch
- Hydraulic winch on lattice/encased support
- Aerial work platform for passenger transport (fixed/extendable/rotating)
- Bucket for concrete
- Bucket for light material
- Debris bucket
- Grapple bucket
- Wheel handling gripper
- Rib-laying pliers
- Rotary blade trimmer

NOTICE

The list of interchangeable equipment is subject to change without notice.



CAUTION

All interchangeable equipment not manufactured by Magni Telescopic Handlers S.r.l., in order to be connected to its vehicles, must mandatorily have test clearance and approval from Magni Telescopic Handlers S.r.l..



WARNING

The use of unauthorised equipment by Magni Telescopic Handlers S.r.l. entails full liability on the part of the operator in terms of damage to property and injury to persons.

General description of the vehicle

Front/left side

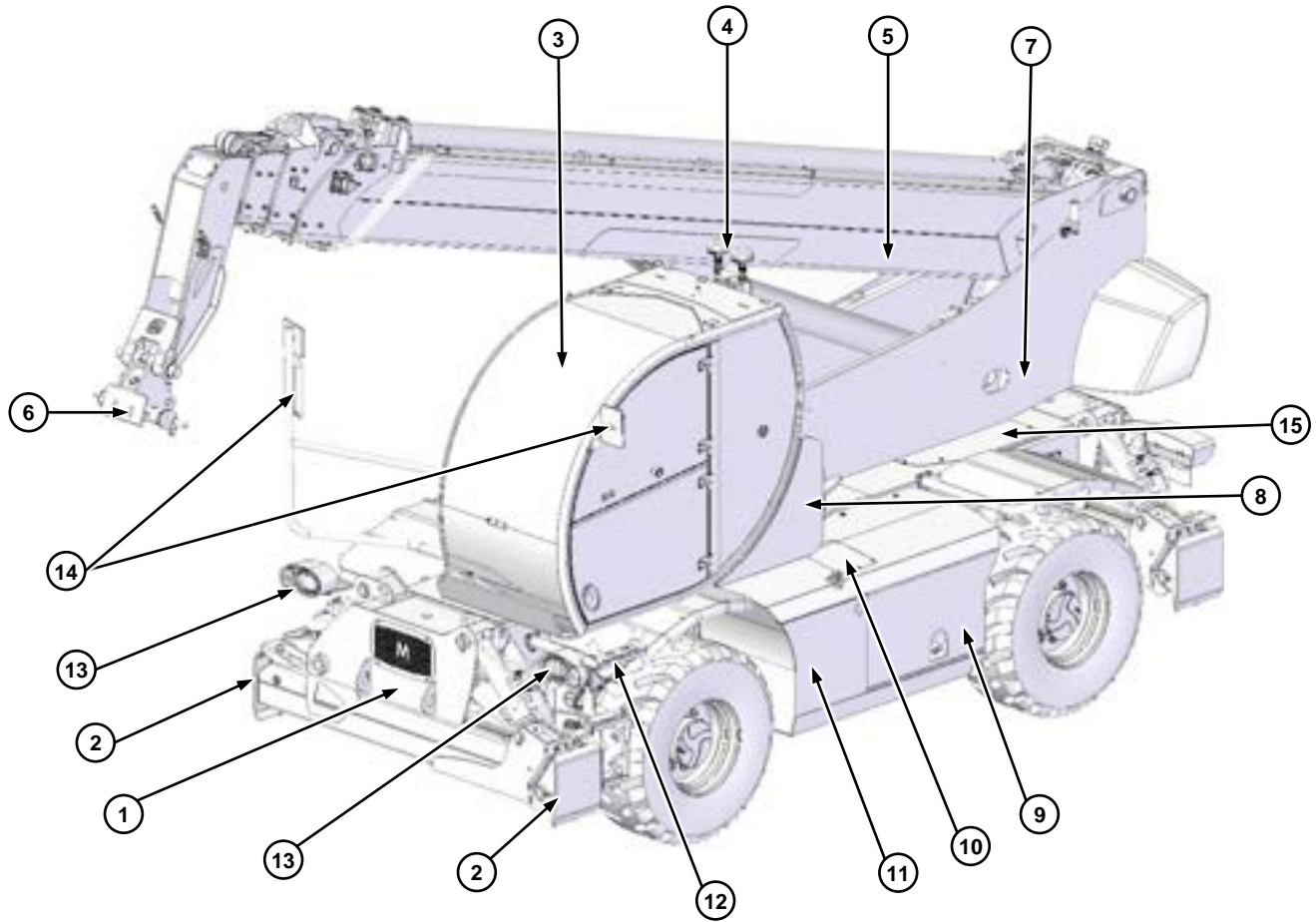

1	Chassis	2	Front stabilisers
3	Driving and manoeuvring cab	4	Manoeuvre/alarm signal lights
5	Telescopic boom	6	Interchangeable equipment quick-fit coupling
7	Rotating turret frame	8	Electrical system technical compartment, rotating part / cab air filter
9	Electrical system technical compartment, slewing variable-reach truck part and AdBlue tank	10	Hydraulic service oil tank
11	Diesel tank	12	Main access ladder
13	Slewing variable-reach truck front lighting devices	14	Rear view mirrors
15	Battery compartment		

Rear/right side

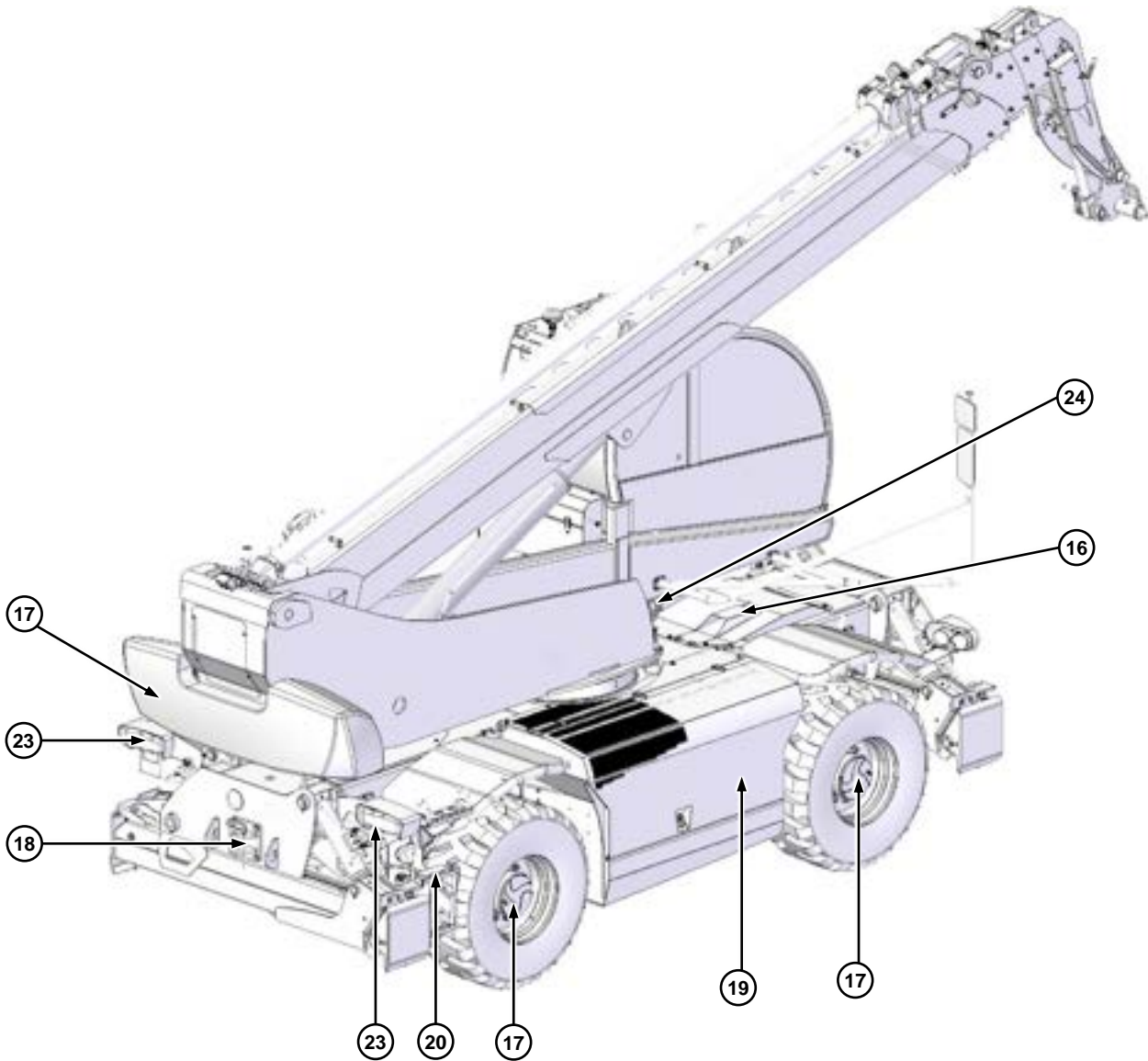

16	Engine air filter compartment	17	Counterweight
18	Tow hook	19	Engine compartment
20	Secondary access ladder (depending on vehicle model)	21	Front axle
22	Rear axle	23	Slewing variable-reach truck rear lighting devices
24	Turret rotation lock pin		

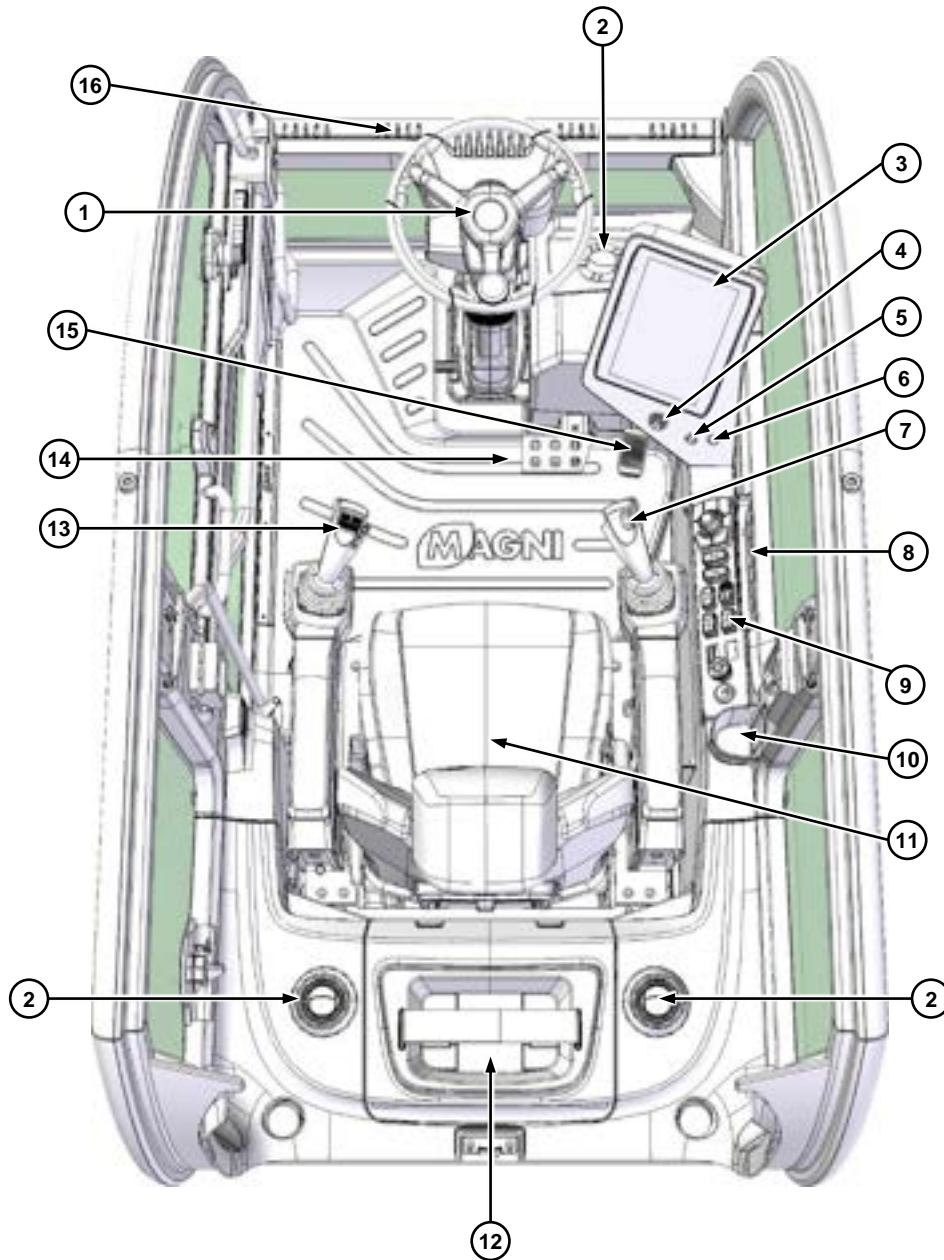
Cab interior (plan view)

1	Steering wheel	2	Air vents
3	Multiple function display	4	Ignition key
5	Anti-tilt limiter override key	6	Wired radio override key on aerial work platform
7	Right joystick	8	Document/device pocket
9	Control dashboard	10	Beverage holder
11	Seat with headrest	12	Location for radio control when not used
13	Left joystick	14	Brake pedal
15	Accelerator pedal	16	Air blower for the windscreen

Cab interior (front view)

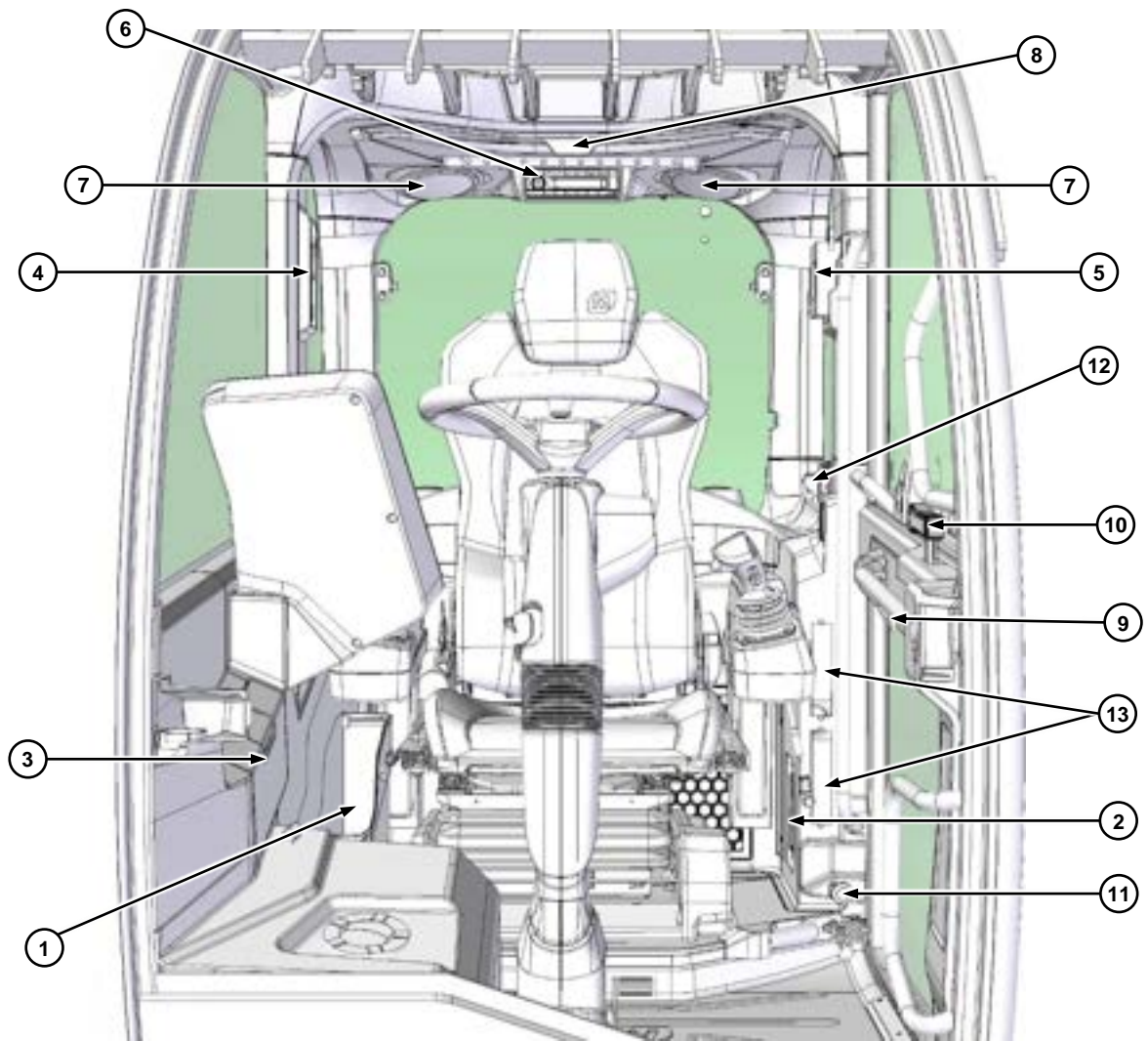

1	Document pocket	2	Battery charger housing for radio control
3	Fuse compartment and operating system USB	4	Rear window breaker hammer seat for emergency exit
5	Emergency key seat with safety glass breaker hammer	6	Vehicle radio
7	Loudspeakers	8	Sunshade
9	Hatch opening lever	10	Door upper portion opening lever
11	Open door lock release knob, from the ground	12	Open door lock release knob, from the cab
13	Air vents		

Safety labels

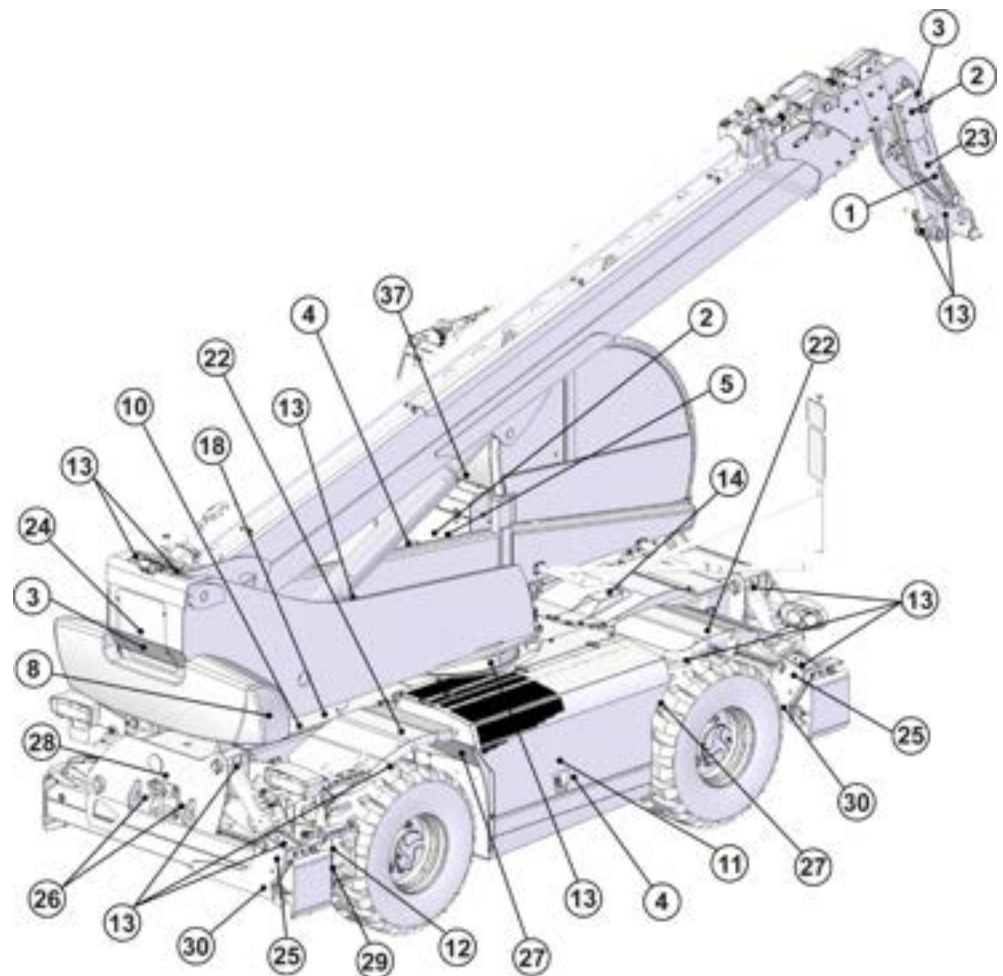
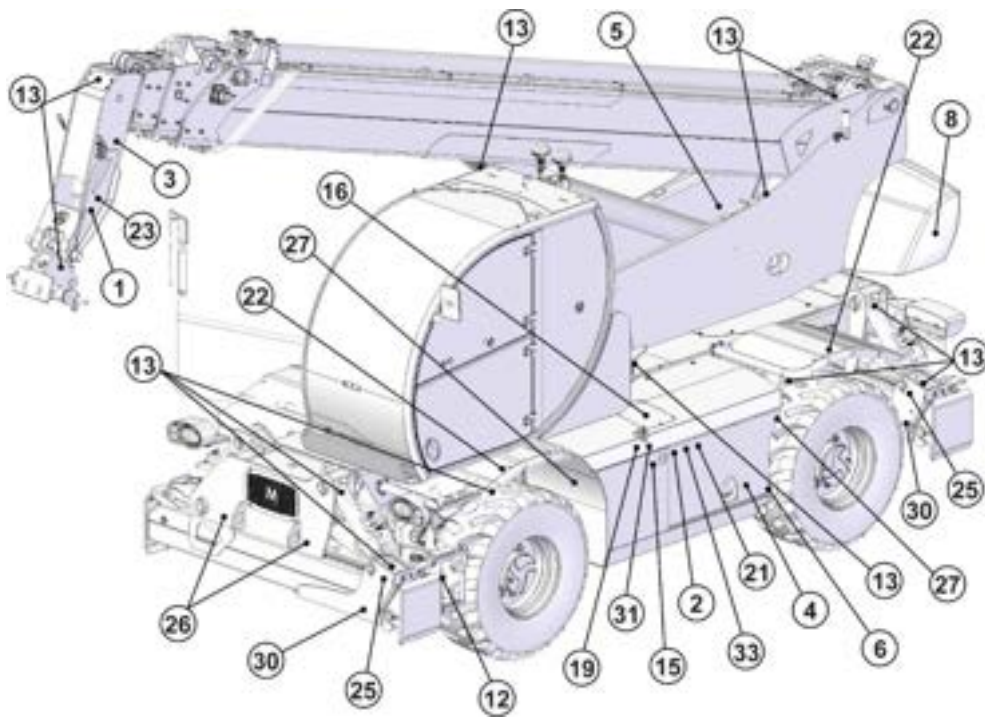

Engine compartment

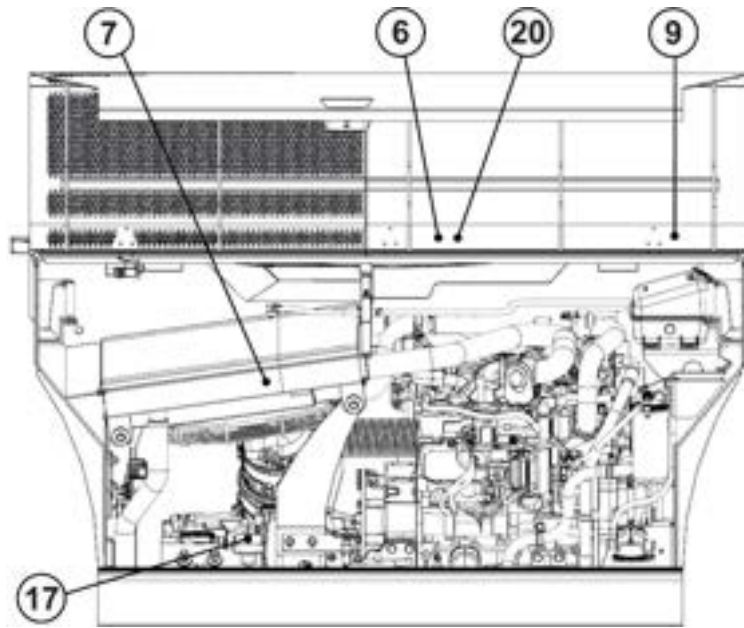



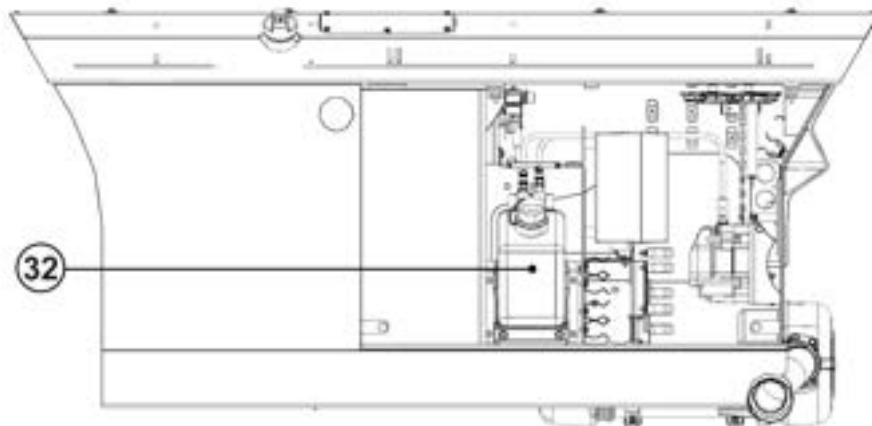



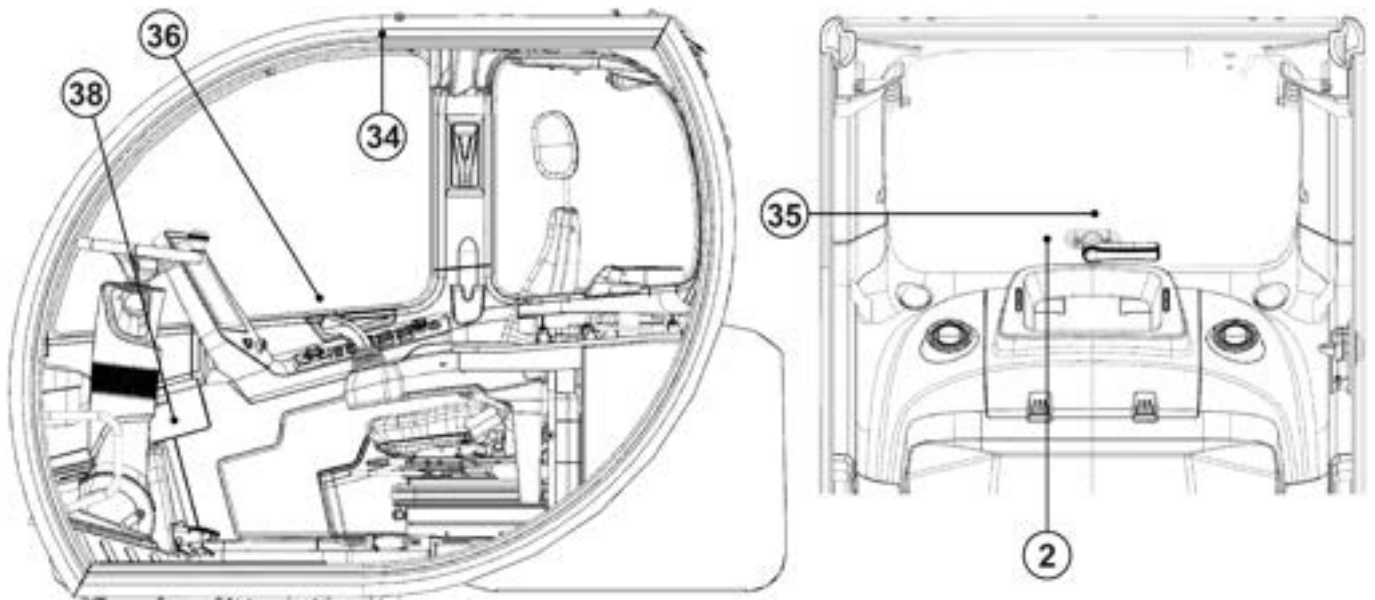

















Service compartment



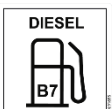

Cab

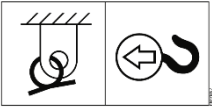
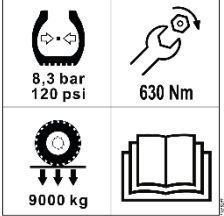
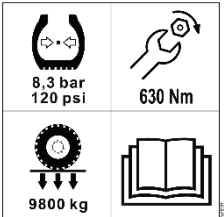
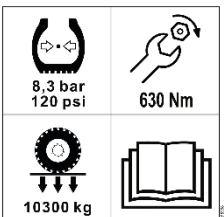
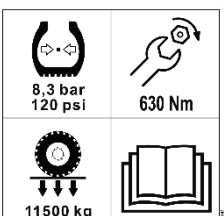
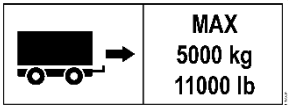

<i>Ref.</i>	<i>Sticker</i>	<i>Code MAGNI</i>	<i>Description</i>
1		90066	Suspended load warning sticker
2		91579	Electric voltage warning sticker
3		91580	High pressure fluid warning sticker
4		91582	Crushing hands warning sticker
5		91645	Pressure accumulator warning sticker (see manual)
6		91687	Hot surface warning sticker
7		91689	Cooling fan warning sticker
8		96118	Ballast handling warning sticker
9		92514	Coolant cap warning sticker
10		93473	Multiple danger warning sticker
11		93469	Engine multiple danger/warning sticker (see manual)
12		91591	Multiple ladder warning sticker

<i>Ref.</i>	<i>Sticker</i>	<i>Code MAGNI</i>	<i>Description</i>
13		03439	Grease nipple information sticker
14		91698	Air filter information sticker
15		91694	Hydraulic fluid level information sticker
16		92499	Hydraulic fluid filler cap information sticker
17		91592	Battery disconnection information sticker
18		93471	Information sticker/no open flame in battery compartment
19		91693	Diesel filler cap information sticker
20		92515	“Wear headphones” information sticker
21		92504	“Do not set fire” sticker
22		91625	No sitting on vehicle mudguards information sticker
23		91604	No climbing on or standing under the interchangeable equipment sticker
24		93474	Danger/information sticker "Do not use high-pressure cleaner on boom pipes"

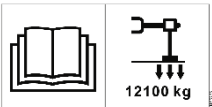
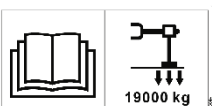
<i>Ref.</i>	<i>Sticker</i>	<i>Code MAGNI</i>	<i>Description</i>
25		91675	Lifting point information sticker (see manual)
26		91657	Attachment and tow point information sticker
27		92167	Information sticker about tyre pressure, nut tightening and under-wheel load (see manual) (Present on RTH 5.18 vehicle models)
		95397	Information sticker about tyre pressure, nut tightening and under-wheel load (see manual) (Present on RTH 5.21 and RTH 5.23 vehicle models)
		95398	Information sticker about tyre pressure, nut tightening and under-wheel load (see manual) (Present on RTH 5.25 vehicle models)
		93045	Information sticker about tyre pressure, nut tightening and under-wheel load (see manual) (Present on RTH 6.22 and RTH 6.26 vehicle models)
28		98294	Information sticker about maximum weight that can be towed by the vehicle
29		91678	No step up sticker (see manual)
30		95266	Information sticker about load under stabiliser (see manual) (Present on RTH 5.18, RTH 5.21, RTH 5.23 and RTH 5.25 vehicle models)
		93044	Information sticker about load under stabiliser (see manual) (Present on RTH 6.22 and RTH 6.26 vehicle models)

Ref.	Sticker	Code MAGNI	Description
31		43221	Information sticker ULTRA LOW SULFUR DIESEL FUEL ONLY
32		43141	AdBlue / DEF ONLY tank sticker (only for D/D engines [Stage V])
33		91703	AdBlue filler cap information sticker (only for D/D engines [Stage V])
34		11071	Sticker for FOPS - ROPS certified cab
35		70784	Emergency exit sign sticker on rear window
36		93478	Cab control information sticker
37		39644	LWA 104 dB noise level sticker (Present on RTH 5.18 vehicle models)
		27038	LWA 106 dB noise level sticker (Present on RTH 5.21, RTH 5.23, RTH 5.25, RTH 6.22 and RTH 6.26 vehicle models)
38		94431	Sticker with key of fuses and relays in the technical compartment inside the cab

NOTICE

To request commercial stickers (e.g. stickers depicting logos, vehicle models, etc.) please take note of the relevant codes and refer to the Magni Telescopic Handlers Spare Parts Department.

FEATURES OF THE VEHICLE

Vehicle features and main safety devices

The telescopic handler consists of the following main components:

- Chassis made of two steel side members and reinforcing crossbars made of high-strength alloy steel.
- Four hydraulically operated folding/tilting stabilisers at the ends of the cross members
- Oscillating levelling steering front axle;
- Oscillating swinging steering rear axle;
- Right compartment of the slewing variable-reach truck for diesel engine, cooling system and engine equipment.
- Left compartment of the slewing variable-reach truck for diesel tank, hydraulic fluid tank, urea tank (for models equipped with Stage V emission-compliant engines), electrical compartment/vehicle control units.
- Left side vehicle compartment (behind cab) for electrical system (ECU).
- Batteries located in the centre of the chassis.
- Hydrostatic transmission. Hydrostatic pump located on the engine power take-off and hydraulic motor connected to the front axle gearbox (connection cardan shaft from front axle to rear axle, 4WD).
- Swivelling turret on fifth wheel (continuous rotation, 360°, or limited, $\pm 200^\circ$) depending on vehicle model)
- Telescopic boom pivoted on the chassis installed on the fifth wheel raised and extended by double-acting hydraulic jacks and transmission of movements to the extensions with chains (for models that are equipped with them). At the end of the main boom there is a mechanical device (quick-fit coupling for interchangeable equipment) that can be moved by means of hydraulic jacks for swinging.
- Cab complete with all controls for driving/moving the handler, electrical/electronic devices, HVAC system (where present), heating/cooling system, adjustable seat and steering column, vehicle radio, FOPS-ROPS certified safety cell according to EN 1459 requirements.
- Street lighting and emergency signalling devices.



WARNING

Before using the vehicle, ensure that all safety devices are visible and working properly. Should you find any anomalies in the safety devices, stop working until the fault has been repaired (Contact your dealer or Magni Telescopic Handlers Support Service).

Check that the symbols and safety stickers are clearly legible. For your own safety and that of others, do not disable or alter operation of the safety devices.

Vehicle cab

The cab structure is designed, tested and certified (Level II) ROPS/FOPS.



Climbing on to or climbing down from the vehicle



Access to the inside of the cab after opening the door by means of the lock-protected handle with key, located in the lower portion of the door, pulling it outwards.

NOTICE

Always use the steps and handles on the slewing variable-reach truck frame and cab to climb on to or down from the vehicle.

Before climbing on to or climbing down from the cab, clean all steps and handles thoroughly. Damaged steps or handles must be repaired immediately.

Do not climb on or down from the vehicle with your back to it.

Always use three gripping points when climbing up or down: two hands gripping the handles and one foot on a step, or two feet on the steps and one hand gripping the handle.

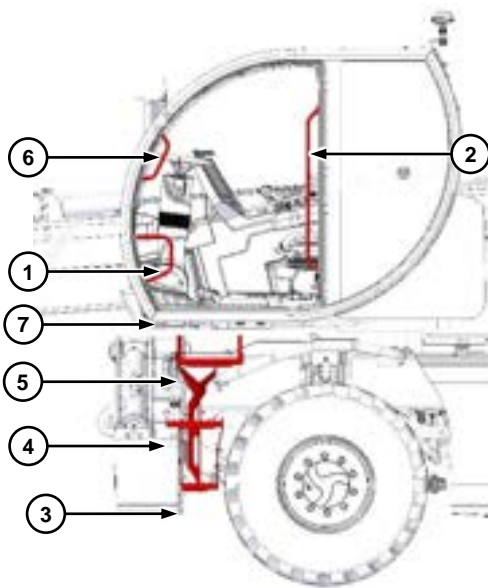

To get in the cab correctly, follow the sequence below:

- grasp the two handles ① and ② located inside the cab,
- go on the steps ③ ④ ⑤,
- with your left hand grasp the handle ⑥, always keeping your grip on the handle ②,
- enter the cab by crossing the threshold ⑦.

To open the door from inside the cab, press the lever on the handrail as shown below, then push the door outwards.

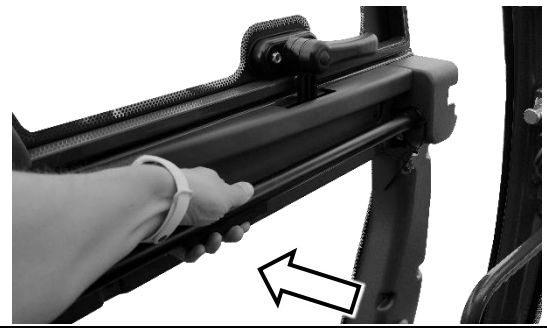

To get out of the cab correctly, follow the sequence below:

- grasp the two handles ⑥ and ② located inside the cab,
- cross the threshold ⑦ of the cab,
- get off the steps ⑤ ④ ③,
- with your left hand grasp the handle ①, always keeping your right hand on the handle ②.

WARNING

Do not climb on or down when the vehicle is in motion.

Do not climb on or down from the vehicle carrying tools or other objects. Load the tools required before climbing on the vehicle. Unload the tools from the vehicle using a rope to lower these to the ground.

CAUTION

Do not use any of the vehicle's control devices (joystick or steering wheel) as a handhold for getting in or out of the cab: these are not designed for such purpose and could be damaged, even causing the operator to fall.

Door window

To open the upper part of the cab door, act on the "L" lever by turning it upwards. Then, once released, push the half-door, accompanying it as far as it will go to the lock on the rear window.

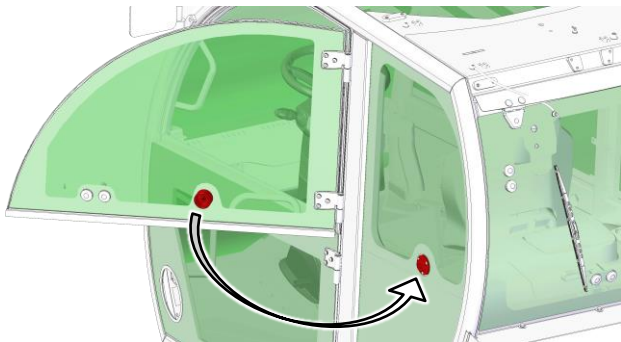
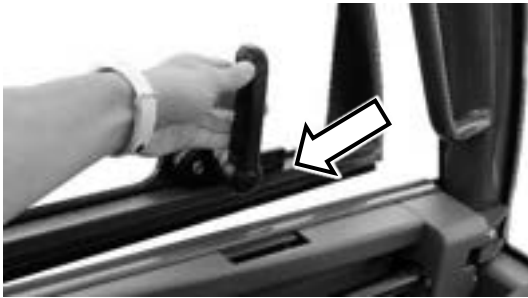

To unlock the half door, turn the knob on the left rear window behind the driver's seat.



The procedure for unlocking the door window or the entire door (when the window is fixed) can also be performed from outside the vehicle, by turning the knob located at the base of the vertical cab cross member to the left of the driver's seat.



Rear window

To open the rear window, act on the handle at its base by turning it to the left; the rear window opens automatically by means of gas springs.

To close it, grasp the handle by pulling it towards the inside of the cab and lock it by turning it to the right.



Emergency exit



The rear window also serves as an **emergency exit**, as recalled by a special sticker ①. To open it, follow the procedure described above. If it is not possible to exit through the rear window, there is a **RED hammer** on the right door jamb of the cab; this must be used (in the event of an emergency) to break the glass of the cab to facilitate the driver's exit.

NOTICE

Contact your dealer to have the glass replaced.

Driver's seat



NOTICE

The vehicle's driver's seat not only accommodates the driver of the vehicle in the most comfortable way possible thanks to the adjustment possibilities listed below, it also has the function to enable manoeuvre of the vehicle itself both in terms of translation and general movement when handling loads with a telescopic boom: incorrect seating, detected by presence sensors, inhibits all movements by signalling the error on the multiple function display.

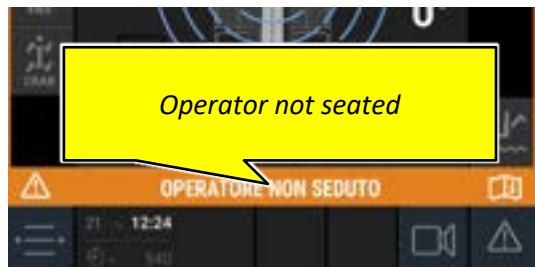

Adjustments



- 1- lever for longitudinal adjustment of the entire seat block: act on the appropriate lever to release the translation of the entire seat to and from the driving pedals; once the correct position has been found, release the lever;
- 2- safety belt with retractor: always fasten the safety belt before starting any operation with the vehicle.

CAUTION

Always check the fabric of the safety belt, the buckle and winder, every time before using the vehicle.

Replace the seat belt or components found to be worn or damaged.

- 3- backrest inclination adjustment lever: lift the lever to unlock the backrest and adjust its inclination; once the correct position has been found, release the lever; the backrest also provides a folded position above the seat to give access to the rear portion of the cab

- 4- lumbar cushion adjustment knob: use the knob to adjust the depth of the lumbar portion of the backrest;
- 5- seatbelt lock: once the seatbelt is fastened, press the red button on the top to release it;
- 6- longitudinal seat adjustment lever: act on the lever to adjust the distance of the seat surface from the backrest; once the correct position has been found, release the lever;
- 7- armrest and peripheral distance adjustment lever; act on the lever to adjust the distance of the armrests and joysticks from the seat/backrest; once the correct position has been found, release the lever;
- 8- seat tilt adjustment lever: pressed with the seat unloaded, raises the front part of the seat; pressed with the operator regularly seated, unlocks the position; release the lever to the desired tilt size.
- 9- pneumatic seat suspension adjustment

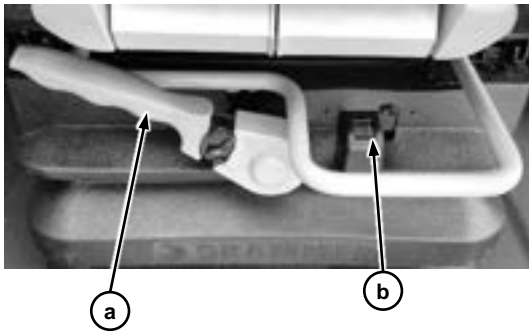

Act on the lever **a** to increase or decrease the pressure on the spring until the indicator **b** is green: we recommend adjusting the air spring when the seat is unloaded to make it easier.

Armrests

Beside the seat on both sides are armrests and joysticks to control the vehicle's hydraulic functions.

These can be raised alongside the seat backrest to facilitate maintenance operations on the cab (the right one) and to facilitate getting out of the cab (the left one).

Joystick

The "RTH" vehicles are equipped with two joysticks near the driver's seat armrests. The joysticks control the main hydraulic movements of the vehicle.



CAUTION

To impart commands using the joysticks, keep the confirmation button on the joysticks and indicated below pressed.

Not pressing the confirmation button prevents accidental movements of the vehicle.

The joystick commands are inhibited if the operator is not seated correctly in his/her seat.

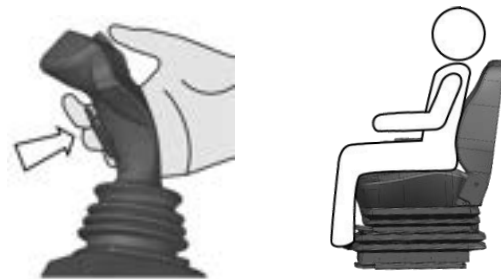

The anomalies described above are shown by means of visual signals on the multiple function display next to the seat.

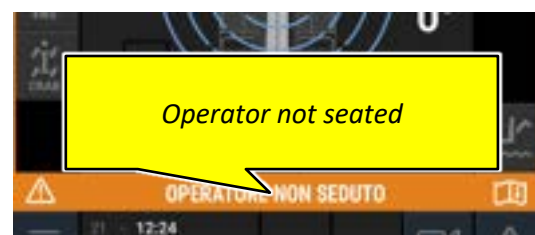
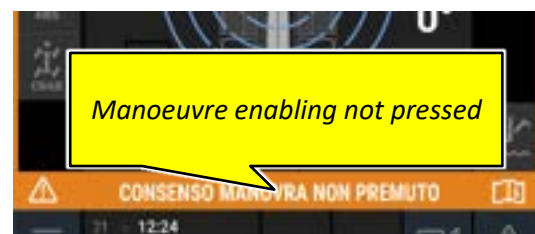

Right joystick

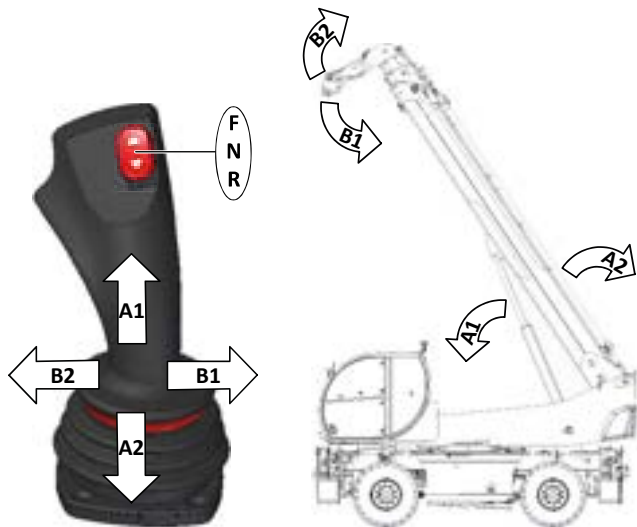

FNR: the red-coloured rocker switch on the top of the joystick activates the vehicle's drive converter:

- at the centre the transmission is in NEUTRAL,
- when pushed forwards the forward movement transmission is activated,
- pressing reverse activates the reverse gear at the same time as the external warning buzzer, reversing lights and activation of the camera video on the control display.

A1: moving the joystick forward lowers the telescopic boom;

A2: moving the joystick backwards lifts the telescopic boom;

B1: moving the joystick to the right retracts the swing jack by rotating the equipment downwards;

B2: moving the joystick to the left extends the swing jack by rotating the equipment upwards;

Left joystick

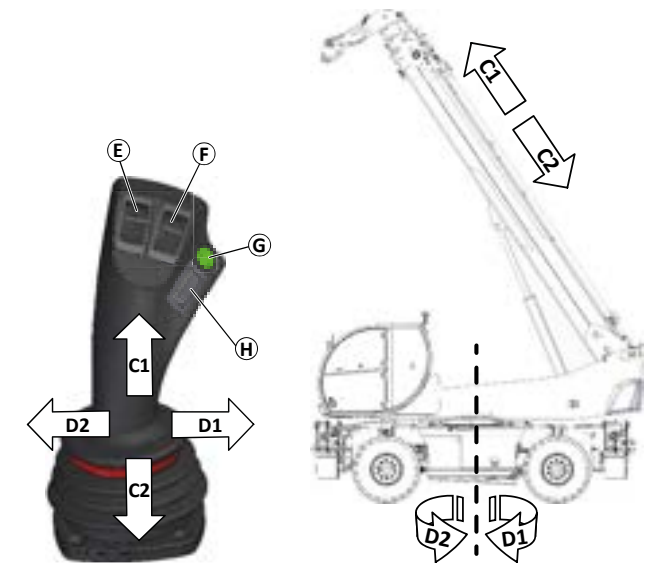

C1: moving the joystick forwards extends the telescopic boom;

C2: moving the joystick backwards retracts the telescopic boom;

D1: moving the joystick to the right rotates the vehicle's turret to the right;

D2: moving the joystick to the left rotates the vehicle's turret to the left;

E and F: the movements controlled by the rollers on the left joystick, manage the hydraulic outputs on the boom head that enable accessory functions to the mounted equipment if fitted. Please refer to the specific user manual of the currently coupled equipment.

G: the green button enables the "EASY ACCESS" function: pressed together with the turret rotation command to the right starting from the turret aligned with the slewing variable-reach truck in the direction of travel, it positions the latter in such a way as to make it easier for the operator to get out of the cab and reach the ladders.

For vehicle models with a long slewing variable-reach truck and second cab access ladder located at the rear right mudguard, with the cab rotated to the right by more than 7°, rotation continues until the latter is reached.

H: the button controls the optional additional hydraulic outlets at the head of the telescopic boom.

Steering column

The steering column is designed to offer various adjustment possibilities, its position can be adjusted in inclination and depth. The correct position of the steering wheel depends on individual preferences:

It must be possible to reach the steering wheel without detaching the shoulders or back from the backrest;

The arms must be bent at right angles when gripping the steering wheel;

The joysticks must not obstruct rotation of the steering wheel while driving, in any manner whatsoever;

The position of the steering wheel must not obstruct the movements of the joysticks, in any manner whatsoever.

To adjust the inclination of the lower part of the steering column, while correctly seated in the driver's seat, press the pedal on the left of the base, shown in the photo, and pull the steering wheel towards you; once you have found the correct position, release the pedal.

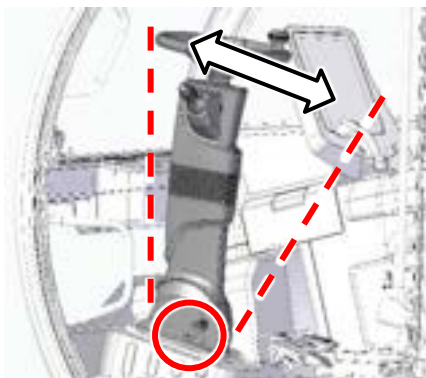

To adjust the inclination of the upper part of the column and the telescopic depth of the steering wheel, use the levers on the right-hand side of the steering wheel.

Pull up the release lever ① to unlock the depth of the steering wheel in relation to the column; once the correct fit has been found, release the lever.

Turn the lever ② outwards to adjust the angle of the steering wheel in relation to the base column; find the right fit and reposition the lever.

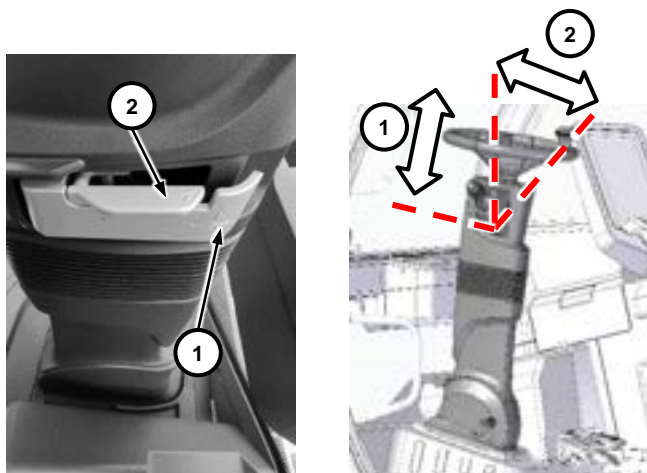

Light, window wiper, horn selector.



The lever on the left of the steering wheel controls the direction indicators, work lights switch and windscreen wipers.

Direction indicators

To activate the direction indicators:

right side: push the lever forwards and upwards,

left side: pull the lever backwards and downwards.

The direction indicators are deactivated when the lever is in the central position.

Lights switch

To activate the lights, rotate the first ring nut to the left:

○: turned off,

☞☞: road lights on,

☞☞☞: low beam light on.

To activate the low beams ☞☞☞:

move the lever forward for continuous activation, apply slight traction towards the steering wheel to activate the high beam headlights. The lever will return immediately to the neutral position when released.

Horn

To use the horn, press the button on the tip of the lever.

Do not use the horn in densely populated spaces or where expressly banned by means of signs.

NOTICE

The horn emits a short warning if connected with a radio control (optional).

Steering wheel



Use the steering wheel to guide the movement of the vehicle. A knob is provided to drive with one hand, keeping the other free for other controls.

NOTICE

Do not use the knob for driving on public roads. In these situations, keep both hands on the steering wheel to have better control of the vehicle.

There are three steering modes:

- two-wheel steering: on front axle
- four-wheel steering with concurrent axles for minimum steering range
- four parallel-axle "crab" steering wheels for lateral movement

The steering mode can be changed from the multiple function display on the "Drive" page and under the following conditions:

vehicle stopped;

wheels of both axles aligned validated by the warning lights.

Please refer to the "Steering Mode" section.

Windscreen Wipers/Washers

The vehicle is equipped with three windscreen wipers; their activation occurs in series and is controlled by the right ring nut closest to the column.

Turning it backwards (towards the driver's seat) controls:

O: all windscreen wipers deactivated;

first position: the front window wiper;

second position: front window wiper and top window wiper;

third position: front window wiper, top window wiper and rear window wiper.

To activate the water jet for cleaning the vehicle windows, from the condition of all window wipers off, turn the ring nut forwards (towards the front window): this activates the simultaneous jet on all three windows with automatic activation of the brushes, which will work for a limited time.

Pedals

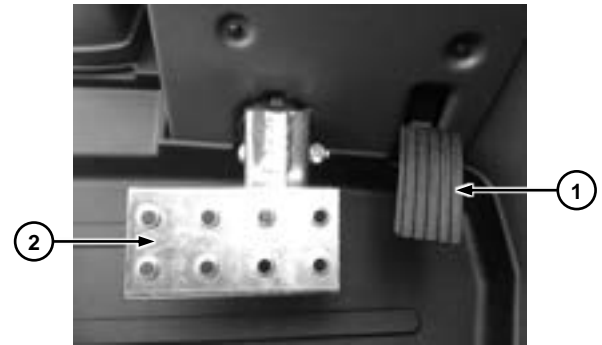

Accelerator pedal

Press the accelerator pedal ① to increase the I.C. engine speed.

Release the accelerator pedal ① to decrease the I.C. engine speed.

Brake pedal (inching)

Press the brake pedal ② to slow down and/or stop the vehicle

In the first 20 mm (0.8 in) of travel, the service brake pedal functions as an *inching* pedal similar to the operation of a clutch, allowing the simultaneous depressing of the accelerator pedal to increase engine revs even at minimal speeds.

This increase in engine speed allows maximum power of the I.C. engine and consequently maximum lifting performance.

Control dashboard

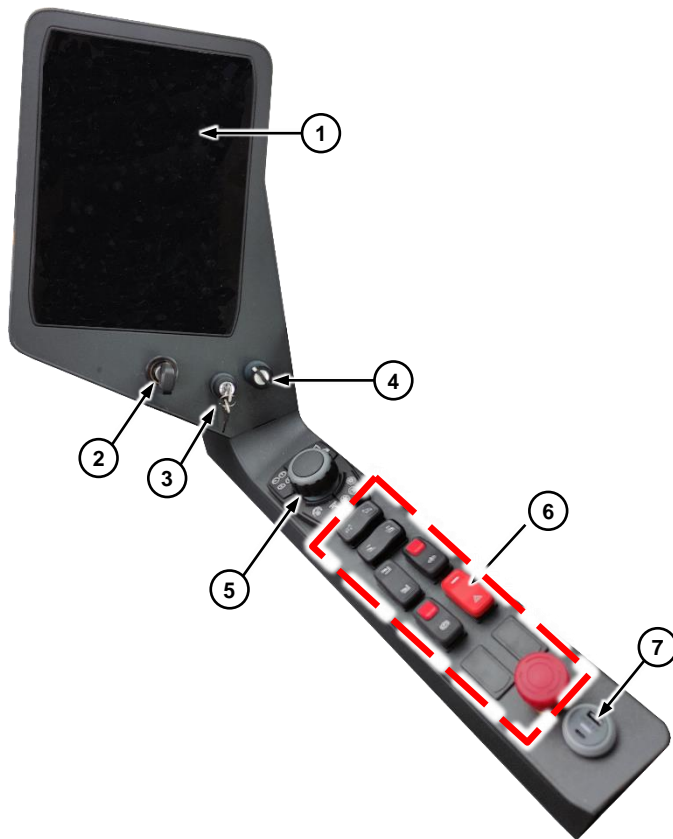

- ① - multiple function display
- ② - vehicle ignition key;
- ③ - safety system limit override key.
- ④ - radio control wiring override key in
- ⑤ - multifunctional manipulator;
- ⑥ - service buttons;
- ⑦ - USB sockets for charging electronic devices.

Vehicle ignition key.

- 0: no electrical contact between vehicle and I.C. engine;
- I: general electrical contact active;
- II: pulse for I.C. engine start.

Safety system limit override key.

In hazardous conditions and operational necessity, the limits of the rollover safety systems can be temporarily deactivated in order to re-establish the conditions necessary to keep the vehicle and operators safe.

For this operation, the iron key must be removed from the dedicated container in the cab and inserted into the slot by pressing and turning it clockwise.

Holding the key in position will automatically activate the acoustic alarm and steady red warning light on the top of the cab to warn of the potentially hazardous situation for those working in the area near the slewing variable-reach truck.

Perform all the necessary movements to solve the emergency and restore the vehicle to safety conditions.

At the end of the procedure, unlock and remove the key and put it back in its container. Replace the glass that was broken earlier.

Key for radio control wiring override in aerial work platform.

With the aerial work platform connected to the vehicle and the radio control properly wired, if it is necessary to regain control from the cab, the black key must be removed from the dedicated box and inserted into its slot.

Once turned clockwise and held, with subsequent visual indication in the multifunctional display with dedicated banner, it is possible to control movements from the cab; in this condition, only one movement at a time is permitted, and always within the working area provided for the platform connected to the vehicle.

At the end of the procedure, unlock and remove the key and put it back in its container. Replace the glass that was broken earlier.

Multifunctional manipulator;

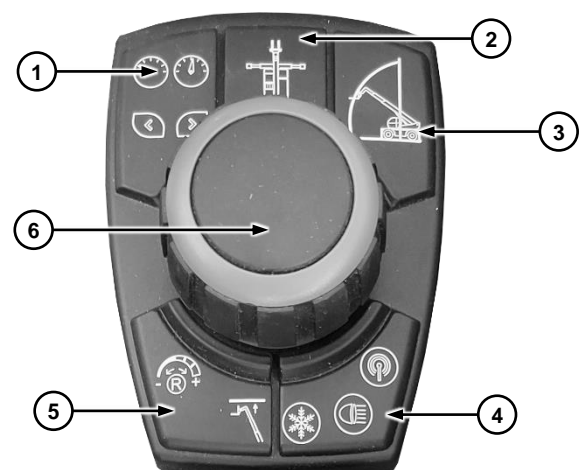

The joypad consists of a central controller and five quick-selection buttons that show on the display respectively:

- 1- DRIVE page with all information about the vehicle in running order,

- 2- STABILIZERS page with all information about the position of the stabilisers,
- 3- LOAD page with all information concerning the working configuration and active load tables,
- 4- COMMANDS page containing all optional vehicle functions,
- 5- LIMITS page containing configurable parameters for safe use of the vehicle.

As the manipulator rotates, its function is to move the command selection area, coloured blue, in the displayed page; to activate or deactivate the chosen command, press the manipulator.

NOTICE

More details on the multifunctional display pages in the dedicated section.

Service buttons

NOTICE

The buttons under the manipulator can vary in quantity, functions and arrangement depending on the vehicle model and its configuration.

NOTICE

With the “automatic page” function active in the multiple function display, when any button is pressed that commands the vehicle movements, the information page related to the activated movement is displayed, regardless of the page displayed in that moment:

- if stabilisers are activated, the “STABILIZERS” page is displayed,
- if levelling is activated, the “DRIVE” page is displayed.

Levelling on wheels

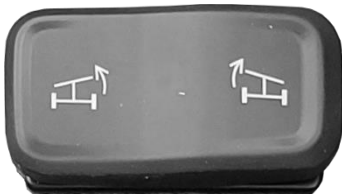

Levelling on wheels is carried out by operating the above switch under the following conditions only:

- inclination of the telescopic boom in relation to the horizontal axis less than or equal to 55°;
- turret rotation not more than 7.5° with respect to the central position.

Pressing the switch to the right will cause the vehicle chassis to incline to the right. Pressing the switch to the left will cause the vehicle chassis to incline to the left.

NOTICE

With boom heights above 3 m, the levelling movement of the vehicle is slower for safety reasons.

You can check the levelling degree by viewing the graph in the centre of the DRIVE page of the display.

When the vehicle is levelled to a value within 3°, the moving indicator ① in the centre of the field is green; if this condition is not met, the indicator is yellow.

To the right of the field, the figure marked with ② indicates the degrees of misalignment with respect to the “X” axis.

When the vehicle is not levelled, the warning light comes on.

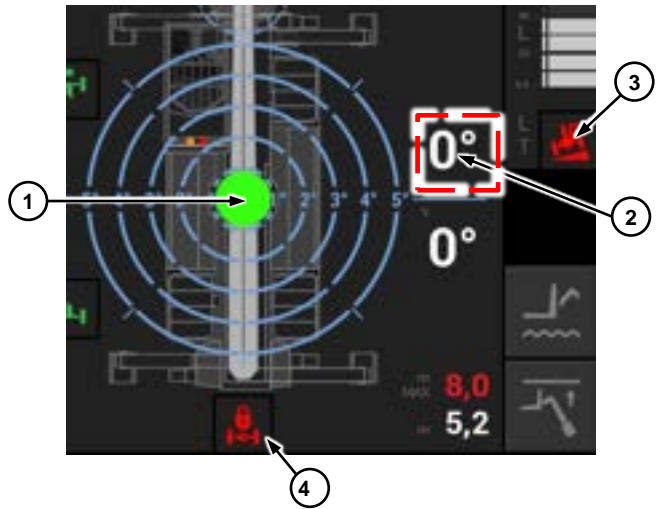

WARNING

With turret rotation greater than ±7.5° the levelling function is inhibited by the tilt lock of the rear axle signalled by the specific warning light ④.

CAUTION

This “levelling on wheels” function is not present on RTH 5.18 models.

Stabiliser controls

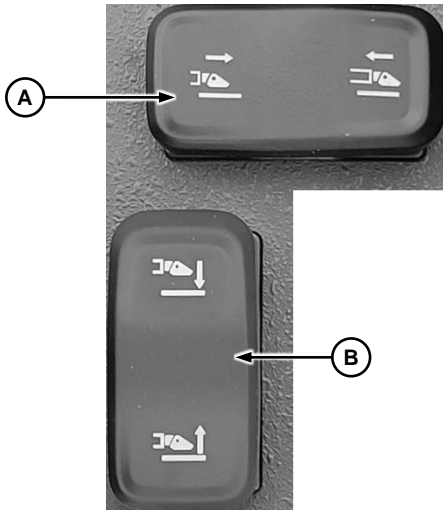

The **(A)** button, which is **only present** on RTH vehicle models with “scissor” type stabilisers, when pressed to its left activates the retraction of the stabilisers; pressed to its right, it activates their retraction.

The **(B)** button for all RTH models, when pressed in the upper side activates the lowering of the stabilisers; when pressed in the rear side, it activates the raising of the stabilisers.

As far as the choice of stabilisers to be moved is concerned, this can be managed on the specific page of the STABILIZERS multiple function display to which we refer.



CAUTION

For “scissor”-type stabilisers, closing is inhibited unless they were first fully raised.



CAUTION

With extended stabilisers, the operator is warned by a special signal on the display when the drive gear is engaged.

Electric emergency pump button



If there is no power supply from the I.C. engine, it is possible to supply the hydraulic flow of movements by means of an electric emergency pump that can be activated by means of the button shown above.

This activation, which lasts a maximum of five minutes so as not to unduly affect the state of charge of the vehicle's batteries, is signalled by the activation of the buzzer and an illuminated message on the display in the cab.

NOTICE

Hydraulic movements performed by means of the electric emergency pump are slowed down compared to normal vehicle operation.



CAUTION

Use this procedure only in cases of pure technical emergency.

Parking brake engagement button



Press the button at the switch serigraphy to engage the parking brake; check that the dedicated red indicator light on the main page of the multiple function display comes on to indicate that it has been engaged



For disconnection, act on the red section of the same button, which acts as a safety switch and then press it down.

When the operation is complete, the manual parking brake is disengaged.

Automatic parking brake

It is possible to enable the parking brake function in automatic mode, which engages as soon as the vehicle stops moving to unlock and allow movement as soon as the accelerator pedal is pressed with the reverse gear engaged.

When the automatic mode is activated, the indicator light identifying the activation is orange.



CAUTION

At a speed below 5 km/h (3.1 mph), if the driver gets up from the seat, the vehicle stops automatically, and the parking brake is engaged.

Hazard lights button



Pressing it will activate the emergency light and the hazard lights simultaneously.

Activation is signalled by a light under the same rocker button and, if on, by the specific light on the DRIVE page of the display.

Red emergency stop button



Press the emergency stop button to stop the I.C. engine and interrupt all vehicle movements; when the button is pressed, the luminous message appears on the display in the cab.

NOTICE

All electronic safety systems of the vehicle remain operational.

NOTICE

To restart the vehicle, unlock the button by turning it clockwise

Double USB socket



At the bottom of the control dashboard, there is a dual USB type A and type C power supply socket with 5V output for charging mobile devices such as tablets and/or smartphones, etc.

Multiple function display



CAUTION

Using the multiple function display while using the vehicle can cause serious accidents.

It is advisable to limit the use of the display while driving to the minimum possible extent to allow prompt identification and avoid obstacles while using the vehicle.

The display has an information/operating function: from here, all vehicle parameters can be monitored in normal use and for diagnostics control, as well as certain operating functions described below can be managed and selected.

The information and functions that can be selected are collected in “pages” that, depending on the vehicle configuration and/or the vehicle operator's choice, can be visible or concealed and indicate information dedicated to the vehicle model itself.

These pages are:

- Menu** page
- Drive** page
- Stabilizers** page
- Load** page
- Limits** page
- Commands** page
- Alarms** page
- Diagnostic** page
- Password** page
- System Info** page

NOTICE

The Password pages, three in total, can be accessed by entering a numerical code and allow access to advanced level diagnostic functions and information subject to permission and authorisation by the Magni Telescopic Handlers Service, with the exception of the Level 1 page for managing parameters for operator use.

Read more in the dedicated section.

The display can be set to display pages in light or dark mode, as described later in the appropriate section, depending on operator preference and external brightness conditions.

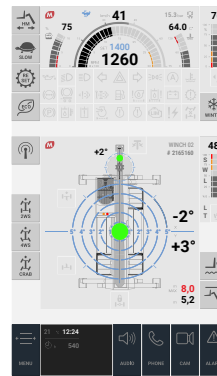

Light mode

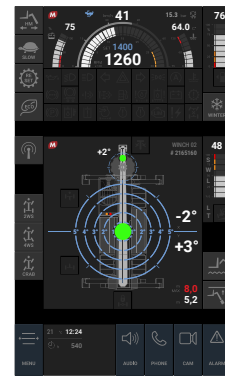

Dark mode

The pages can be consulted manually, by opening the "MENU" page by pressing the dedicated button at the bottom left of the display that shows the index of pages that can be consulted. Otherwise they can change automatically according to the command given to the vehicle: selecting the wheel drive inverter displays the Drive page, moving the telescopic boom displays the Load page, controlling the stabilisers displays the corresponding Stabilizers page.



NOTICE

The choice of whether or not to activate the automatic page change can be selected from the Level 1 Password page described below.

Drive page



The Drive page contains general information on the operating conditions of the vehicle: such as numerical and graphic digital indicators, control and alarm buttons and lights.

Graduated indicators



In the centre of the upper portion of the display, the AdBlue level or hydraulic fluid pressure ① is indicated on the left with both a graduated scale and a numerical value, depending on the vehicle models, whether or not they are equipped with a urea tank; in the centre at the top is the travel speed on wheels indicator ② under the rev counter of the I.C. engine ③. In white is the instantaneous engine rev value, in blue the engine revs set manually by the operator for specific operations.

To the right of the rev counter graph is the graduated scale with the numerical value of the cooling circuit water temperature ④.

On the far right of the display is the graphic and numerical fuel level indicator expressed in percent ⑤.

Levelling indicator

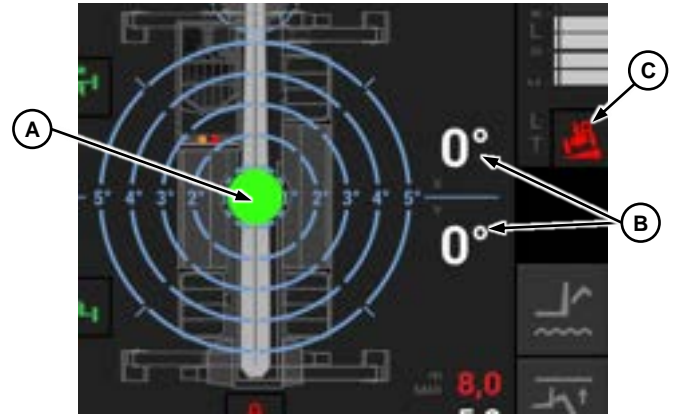

The centre of the page shows the active graph indicating the position of the vehicle chassis relative to an ideal perfectly horizontal flat surface.

The digital spirit level ①, when perfectly centred, is green; as it moves, depending on the angles detected, it provides a graphic indication of vehicle levelling by means of the two numerical values ② beside it, which summarise the inclination value with respect to the longitudinal and transverse axes: beyond 3° of displacement it turns yellow.

The tipping alarm light indicated by the letter ③ is activated:

- with vehicle on wheels, when the angle of the chassis with respect to the horizon exceeds $\pm 4^\circ$ in the longitudinal axis and $\pm 3^\circ$ in the lateral axis;
- with vehicle stabilised at ± 1 in both axes.

Turret rotation indicator

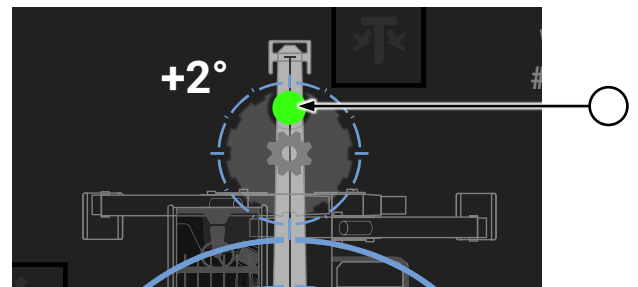

The circular graph above the levelling indicator shows the rotation angle of the vehicle turret: green when in the centre, grey as soon as it deviates from alignment with the vehicle chassis. This information is repeated on all control and operating pages for quick reference.

Anti-tipping system indicator

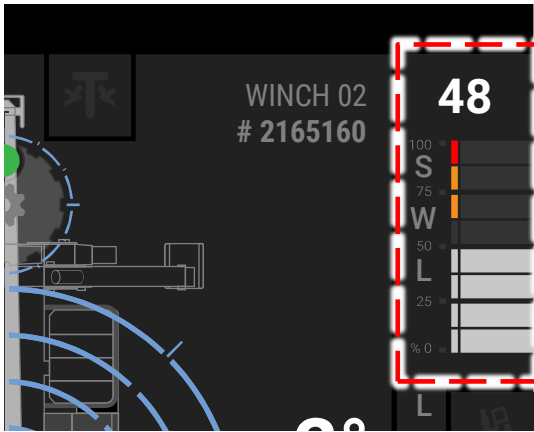









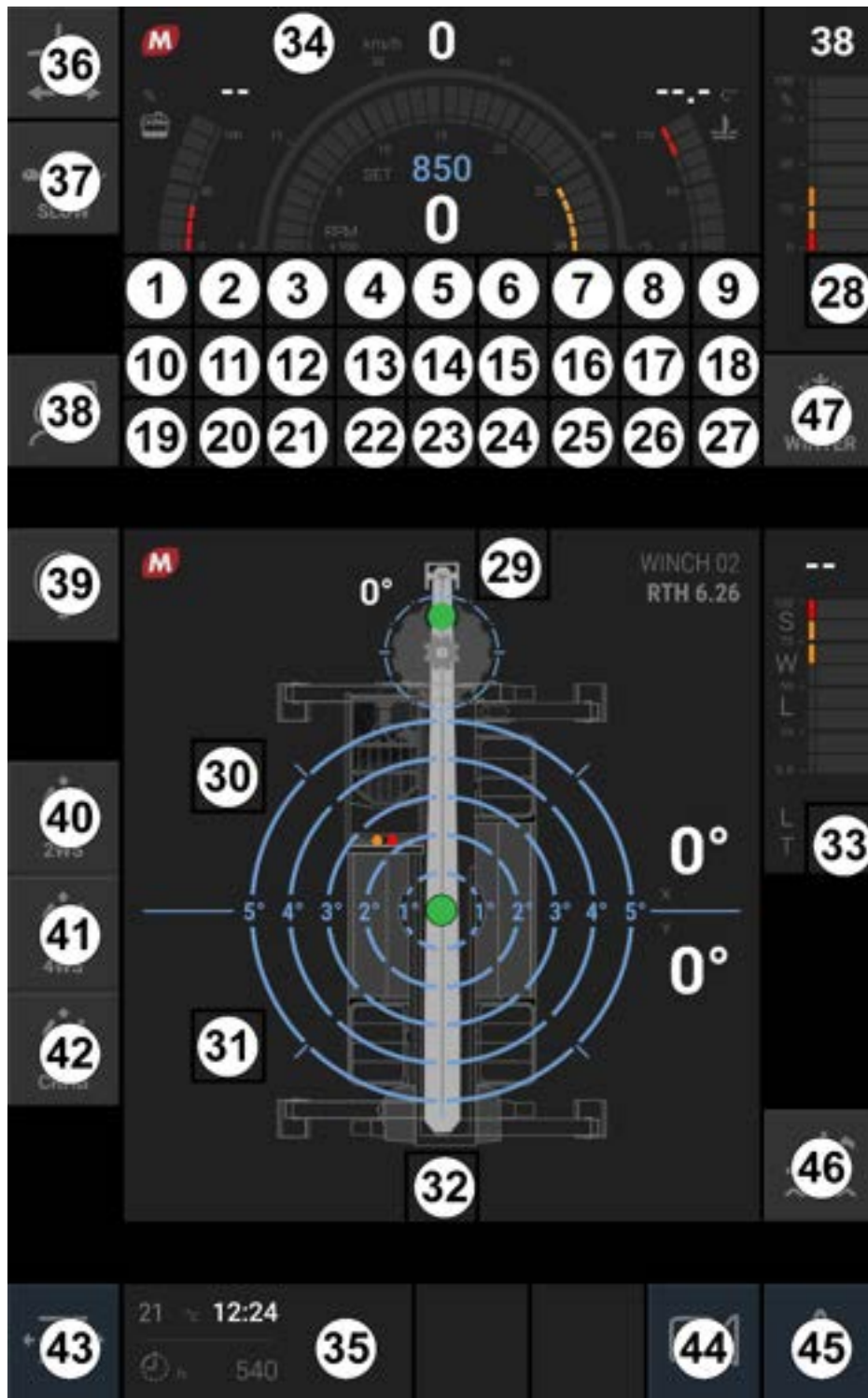









To the right of the levelling indicator is a graduated scale with a numerical value above it that shows, in percentage terms, the load value applied to the equipment installed at the boom end in relation to the maximum rated load value of the equipment itself.

Within a detected load range of 89% the vehicle works normally, with a detected load range between 90% and 99% the red beacon above the cab lights up in flashing mode and the safety buzzer sounds intermittently; when the maximum value is exceeded, the red beacon above the cab remains steady on, the safety buzzer sounds continuously and the related warning is displayed.

















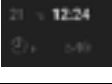

warning



List of warning lights and functions that can be selected in the Drive page



1		Low engine oil pressure	Graphic variation depending on vehicle configuration
		SCR fault	
		Low AdBlue level	
2		Low beams	
3		High beams	
4		Left-side direction indicators	
5		Hazard lights	
6		Right-side direction indicators	
7		Road lights	
8		Active Start & Stop system	
		Start & Stop system in stand-by	
9		High coolant temperature	Graphic variation depending on vehicle configuration
		Engine preheating	
10		Low brake oil pressure	
11		Low trailer brake oil pressure	
12		Fault in exhaust gas system	
		Exhaust gas filter failure	
13		DPF regeneration required	

14		Presence of moisture in the fuel tank	
15		Hydraulic fluid pump filter failure	
16		Clogged hydraulic fluid filter	
17		Low battery level / Electrical generator failure	
18		Transmission failure	
19		Manual parking brake engaged	Colour variation depending on set braking mode
		Automatic parking brake engaged	
20		High hydraulic fluid temperature	
21		Hydraulic system fault	
22		Engine air filter clogged	
23		Engine failure	
24		Engine fault warning	
25		Engine in limited mode due to errors in the control unit	
26		Electrical system failure	
27		Active boom suspension	
28		Low fuel level / refuelling required	
29		Hydraulic turret rotation lock pin engaged	Graphic variation depending on pin position
		Hydraulic turret rotation lock pin disengaged	

30		Front axle aligned	
31		Rear axle aligned	
32		Rear axle lock active	
33		Tipping warning	
34		Speed indicator - active fast movements	Graphic variation depending on the set movement speed mode
		Active slow-motion speed indicator	
35		Outside temperature indicator / Daily time / Vehicle operating hour counter	
36		"Handling Mode" activation button	
37		"Fast movements" activation button	
		"Slow movements" activation button	
38		"Eco mode" activation button	
39		Radio control connection enable button	
40		Front axle steering wheel mode selection button	
41		Four-wheel steering mode selection button with concurrent axle	
42		Parallel-axle four-wheel (crab) steering mode selection button	
43		Link button to list of searchable pages	
44		Rear camera signal activation button on display	
45		Cross-reference button to active alarm list page	

46		“Boom suspension” function activation button
47		“Winter mode” activation button
48		“Reset” button for vehicles equipped with Rexroth transmission pumps

NOTICE

The indicators and selection buttons described here are subject to variations in quantity and position depending on the vehicle models handled and their implementations.

NOTICE

The warning lights described here are shown lit, in normal non-use condition they have a dark grey background.

Handling mode



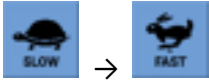

This function enables an increase in the oil flow rate to the service pump and thus in the speed of movement as soon as a hydraulic command is given; this increase does not affect the transmission pump controlled by the accelerator pedal.

Speed of movements



The hydrostatic transmission of Magni Telescopic Handlers has two speeds:

- slow mode, called "tortoise", light no. **34**, ;
- fast mode, called "hare", light no. **34**, .

In "tortoise" mode, the transmission allows the vehicle to move at low speed. Use this mode for precision movements and to move the load.

In "hare" mode the transmission uses both speeds and makes it possible to reach maximum speed. Use this mode for travelling on roads or for rapid movements in the work area.

The active mode is shown by indicator light no. **34**, shown above, while selection button no. **37** indicates the mode that can be set as an alternative to the displayed operating mode.



CAUTION

You can switch between the two modes only under the following conditions:

- vehicle stopped;
- brake pedal pressed;
- gear selector in NEUTRAL position.

If these conditions are not respected, they are indicated individually on the display with specific warning banners.

To switch from "hare" active mode to "tortoise" mode, press button **37** representing the "tortoise". Conversely, to switch from "tortoise" active mode to "hare" mode, press button **37** representing the "Hare".

Reset



This button is displayed for vehicle models fitted with Rexroth transmission pumps. In case of failure to change speed mode or if there is difficulty in engaging the desired speed, stop the vehicle, press the button and accelerate gently to facilitate engagement of the transmission gears.

Eco mode



This function, when enabled, allows engine speed to be managed to reduce fuel consumption and exhaust emissions: once the maximum travel speed has been reached, and maintained, the engine revs automatically decrease, to then increase again should road conditions require it: as in the case of an increase in gradient to be overcome and a sudden drop in speed.

Radio control connection



Pressing this button enables, when present, the connection of the radio control to drive the vehicle from the outside.

Steering modes



The buttons above enable changing the vehicle steering mode according to the graphics shown:

- two-wheel steering: on front axle
- four-wheel steering with concurrent axles for minimum steering range
- four parallel-axle "crab" steering wheels for lateral movement

mode change takes place only under the following conditions:

- vehicle stopped,
- axles, front/rear, aligned confirmed by the illumination of the warning lights



NOTICE

In the condition where the front and rear axles are misaligned, it is recommended to initially centre the rear axle by selecting the four-wheel mode; when the specific light **31** on the display comes on, activate the selection of the front steer axle only until alignment. Now select the desired mode.

Boom suspension**NOTICE**

This function is available only if the specific equipment is present on the vehicle.

The telescopic boom suspension is designed for operating the vehicle on uneven ground with loads raised.

To use this function the following conditions must be respected:

- vehicle on wheels;
- turret in central position;
- telescopic boom height from the ground less than 3 metres (9,8 ft);

To activate the function, press the dedicated button, which turns from grey to blue, and command a small upward movement to the telescopic boom.

This command is reminded by a specific visual signal on the multiple function display.

The boom suspension only works in the presence of the aforementioned conditions: if said requirements are not satisfied during a movement, the function is automatically disabled; if, with the vehicle moving, the parameters required fall within the envisaged limits, the boom suspension is automatically reactivated.

When the vehicle stops, the function is deactivated; to reactivate it repeat the procedure described above.

Winter mode**NOTICE**

This function is available only if the specific equipment is present on the vehicle.

Winter Mode has been designed for vehicles working in particularly cold weather conditions: by activating it with the engine running, it causes the I.C. engine to increase its revs to facilitate the heating of the service hydraulic circuit and the heating of the cab itself; if the operator sits on the driver's seat, the engine revs are reset to the minimum speed.

Stabilizers page

The **Stabilizers** page mainly contains general information on the activity status of the stabilisers.

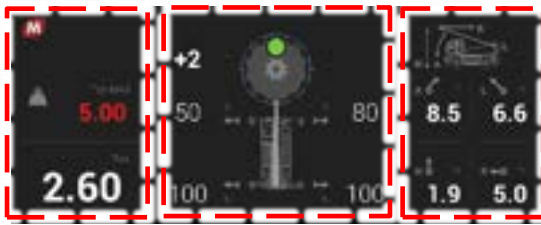

The upper portion of the page, which is also indicated on the Load page, described below, displays the nominal maximum capacity of the installed equipment and the capacity measured in real time on the left. The central portion shows the turret rotation angle indicated by a graphic/numeric indication and the percentage of extension of the individual stabilisers. On the right, the use status of the telescopic boom is summarised with four parameters:

A: boom lift angle measured in relation to the ground from equipment hinge pin axis when not present.

L: extension length: to equipment hinge pin axis when not present or specific load application point for installed equipment;

L: boom height measured from the ground to the equipment hinge pin axis when not present or specific load application point for installed equipment;

L: radius of boom rotation measured from the turret pivot centre to the equipment hinge pin axis when not present or specific load application point for installed equipment

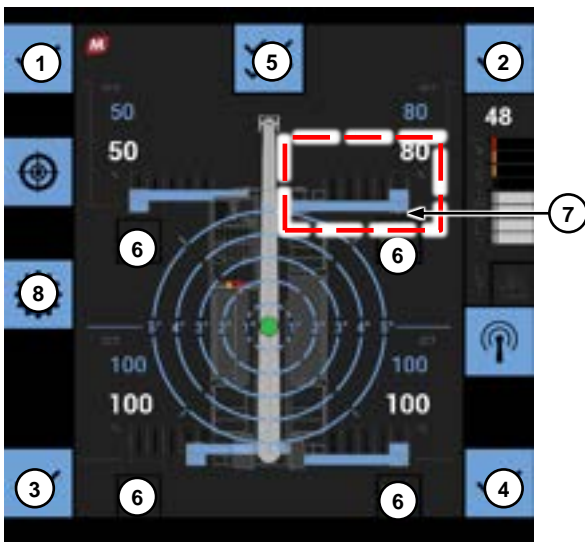

In the central portion of the page, in addition to the graph showing the levelling of the slewing variable-reach truck described above, the stabiliser data are shown.

Buttons ①, ②, ③, ④ enable/disable the movement of the corresponding stabiliser, button ⑤ simultaneously enables/disables the 4 stabilisers

The icons ⑥, according to their graphics, summarise the position of the stabiliser foot:



closed/retracted



open



resting on the ground

The graph ⑦, for vehicles fitted with “**scissor**”-type stabilisers, shows graphically and numerically (0%: closed / 100%: open) the extent of the single stabiliser. These values are the same as those shown in the upper portion of the page and described above.

For vehicles with “**compass**”-type stabilisers, the numerical value expresses the hydraulic pressure of the handling jacks.

Setup function



This button is only enabled on vehicles with “**scissor**”-type stabilisers: in the event of an operational necessity where one or more stabilisers must have a limited extension, extend them to the desired length ① and press the dedicated “**SETUP**” button until the limit value ② equal to the extension value is displayed.



Repeat the operation individually for all stabilisers, if necessary.

NOTICE

The limit value, if set other than 100, i.e. maximum extension, remains in the software's memory and is always visible: to deactivate it, simply deselect the **SETUP** button.

To delete the limit(s), with the **SETUP** function disabled, fully extend the affected stabilisers and then set the new limit by pressing the specific button, at which point the limit value will return to 100, i.e. maximum extension available.

Auto levelling



This function, when enabled and under appropriate ground conditions, manages the levelling of the vehicle chassis, bringing it to the optimal working condition by autonomously manoeuvring the height of the individual stabilisers.

Radio control connection



Pressing this button enables, when present (optional), the connection to the radio control to drive the vehicle from the outside for types of work requiring a different viewpoint.

Limits page



The **Limits** page is structured so that it is possible to set operational limitations to the vehicle's movements should it be necessary to operate more safely depending on the working context.

Limitation of telescopic boom extension

The upper portion of the page contains the same information as described in the section on the *Stabilizers* page.

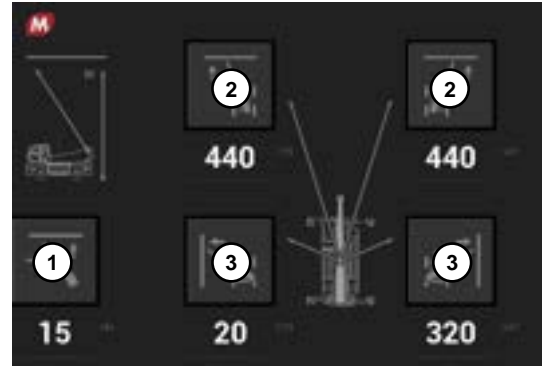

The central portion is dedicated to the extension limitations of the telescopic boom.

In the presence of obstacles in the work area, such as pillars, walls, ceilings, vegetation or other, having defined the position of the vehicle within the work area, in order to limit the risk of impact and increase the operator's safety level, it is possible to set horizontal and vertical extension limitations to the telescopic boom. When the set size is reached, the vehicle stops movement, avoiding collisions with the obstacle previously considered.

NOTICE

In order to perform a correct limitation calibration, define the limit measurement with interchangeable equipment mounted at the head of the boom knowing the size of the load to be handled.

Buttons ①, ② and ③ enable respectively:

- ① Extension limitation in height
- ② Left/right frontal extension limitation
with respect to the axis of the vehicle chassis
- ③ Left/right lateral extension limitation.

To set the limits, position the telescopic boom in the required direction and at the desired measurement, then press the button for 3 seconds in the direction for which you are setting the limit. At this point the software memorises the value corresponding to the measurement detected and displays it. When the function is active, recognisable by the light blue coloured button, the vehicle will stop when this value is reached; deselecting the button, (grey colour) cancels the desired limit.



CAUTION

Extension limitations, once set, remain in memory; to change the value according to the new operational situation, repeat the setting and enabling procedure described above.

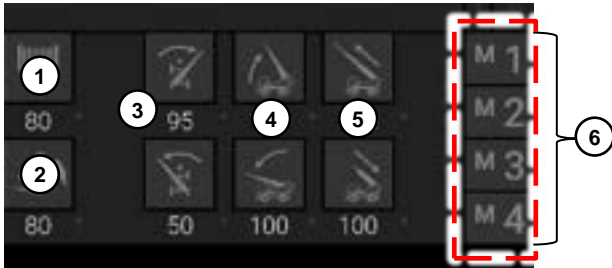

The lower portion of the display is dedicated to managing the hydraulic operating speeds of the vehicle and the installed equipment, the buttons manage:

- ① the hydraulic fluid flow rate at boom head - OPTIONAL use
- ② the speed of the swing command;
- ③ the right/left rotation speed of the turret;
- ④ the telescopic boom up/down speed;
- ⑤ the telescopic boom extension/retraction speed.

The four buttons indicated by number ⑥ identify the four storable and independent configurations to manage the hydraulic speeds listed above.



CAUTION

The values below the buttons identifying the adjustment action indicate the movement speed as a percentage (%):

- **100**: full movement speed as set by the factory,
- **0**: no movement speed = vehicle locked.

so setting decreasing values slows down the movement.

Setting the movement speed limits

To set hydraulic speed values different from the factory settings, first select one of the four programme buttons (**M1**, **M2**, **M3**, **M4**): the selection is highlighted by the colour of the chosen button changing from black (off) to blue (selected).



When one of the four programmes is selected, the buttons showing the functions with adjustable speed change colour from barred black (not selectable) to grey (selectable):



If the vehicle still has factory parameters, all six parameters are set at **0**.

Select the movements concerned one by one and set the desired value:

- press the icon of the function to be set, e.g. ② (*swing speed*), with confirmation of selection identified by the colour changing to blue until the numerical setting keypad appears on the display.

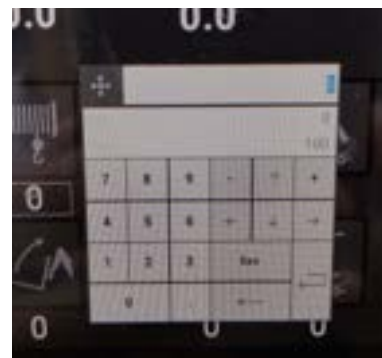
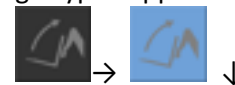

- enter the speed percentage value of the desired function and confirm by pressing the ENTER button on the same keypad to record the desired value.

Once this procedure is performed, the set value for the swing speed remains active until the previously selected programme button (in this case **M1**) is deactivated or the desired speed value is changed.

Load page

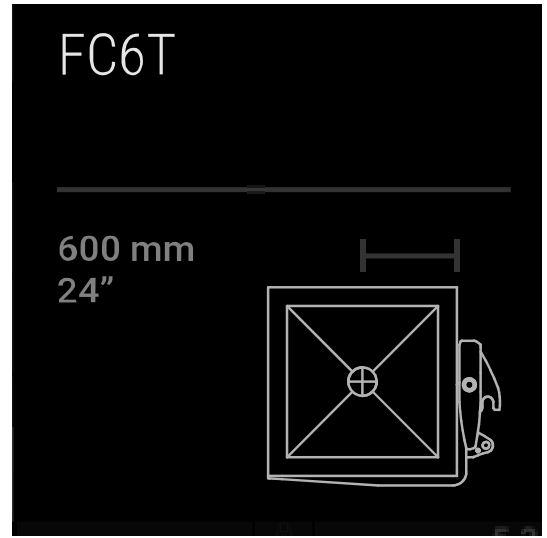
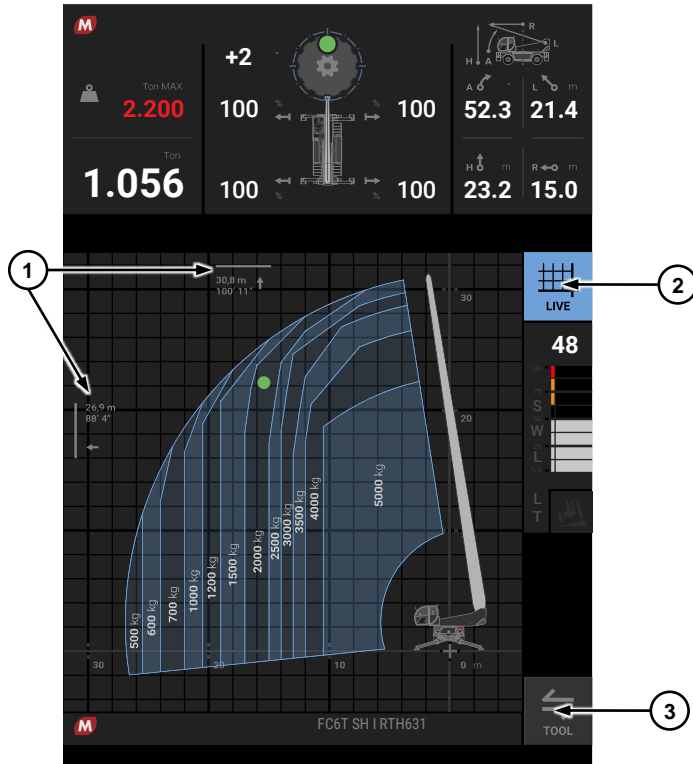

Flow rate diagram in static view

In this configuration, a green mark ① in the display identifies the position of the load application point within the working area divided into load ranges, each limited in depth and height according to the permissible load.

The upper portion of the page contains the same information as described in the section on the **Stabilizers** page.

The central portion displays the working area and the dedicated load diagram with an indication of the maximum permissible depth and height limits ①.

Graphically, the information that can be displayed by pressing ② are:

- static,
- dynamic with a side view,
- dynamic with plan view.

Button ③, when pressed, temporarily displays the summary data of the interchangeable equipment coupled to the vehicle such as model name and load application points, as in the example below.

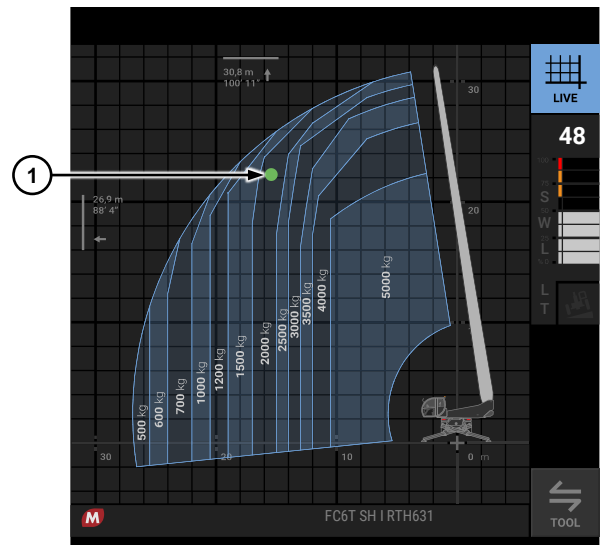

Flow rate diagram in dynamic side view

In this configuration, the load diagram is self-compiled according to the position of the load application point detected as a function of the equipment installed at that particular stage of operation, each time displaying the height and depth limits allowed by the vehicle's safety system.

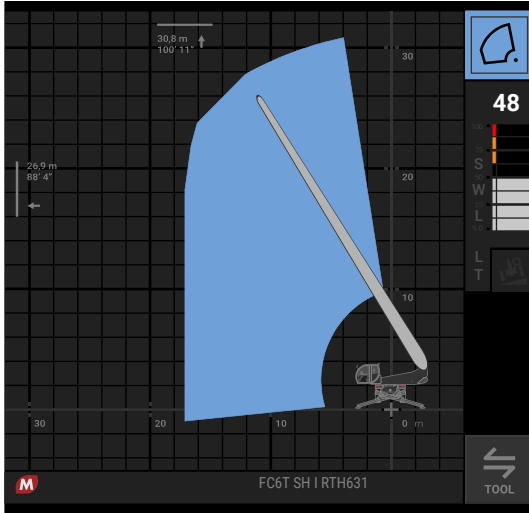

Flow rate diagram in dynamic plan view

The ground working area within which the telescopic boom and attached interchangeable equipment can be moved is displayed, depending on the applied load and its height.

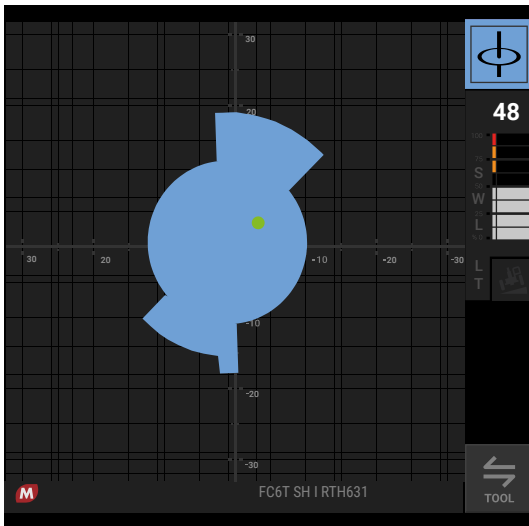

Commands page

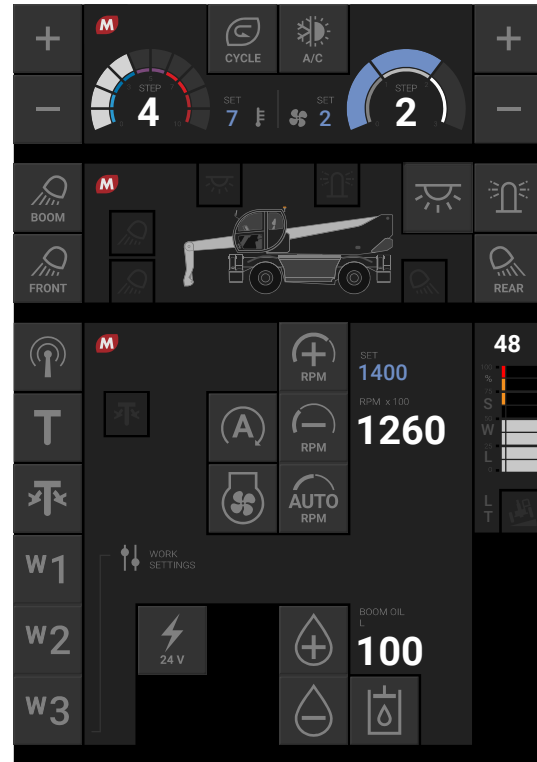

This page contains information and controls of the cab air-conditioning system, controls for activating the exterior working lights and cab reading lights, and buttons for activating accessory functions.

Air-conditioning system

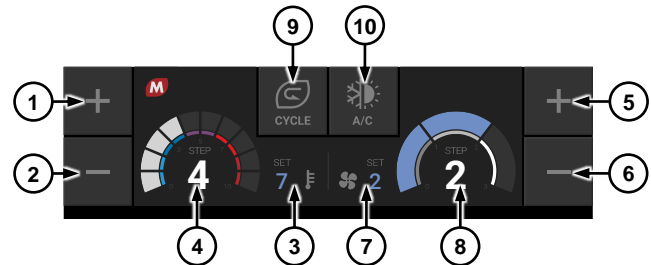

Buttons ① and ② adjust the cab air temperature on a graduated scale from 0 to 10: the selected value is displayed by the indicator ③, while the graduated scale ④ indicates the temperature status in relation to the selected value.

Buttons ⑤ and ⑥ adjust the air flow rate from the cab's interior air vents on a graduated scale from 0 to 3: the selected value is displayed by indicator ⑦, while the graduated scale ⑧ indicates the fan speed in relation to the selected value.

The ⑩ button activates the air-conditioning system with air conditioning.

Auxiliary lighting system

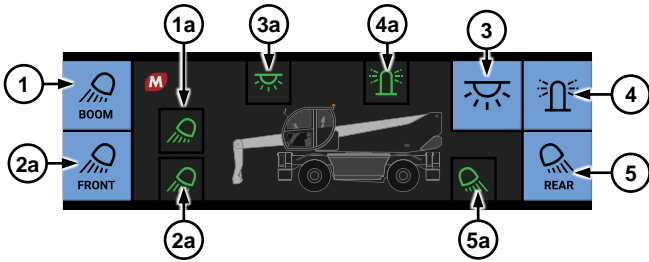

Button ① activates the work lights at the head of the telescopic boom; when activated, the corresponding indicator light 1a ①a lights up.

Button ② activates the front work headlights placed on top of the driving cab; when activated, the corresponding indicator light 2a ②a lights up.

Button ③ activates the work tail lights placed on top of the driving cab; when activated, the corresponding indicator light 3a ③a lights up.

Button ④ activates the orange beacon placed on top of the driving cab; when activated, the corresponding indicator light 4a ④a lights up.

Button ⑤ activates the reading light inside the driving cab over the operator's seat; the corresponding indicator light 5a ⑤a lights up.

Ancillary functions

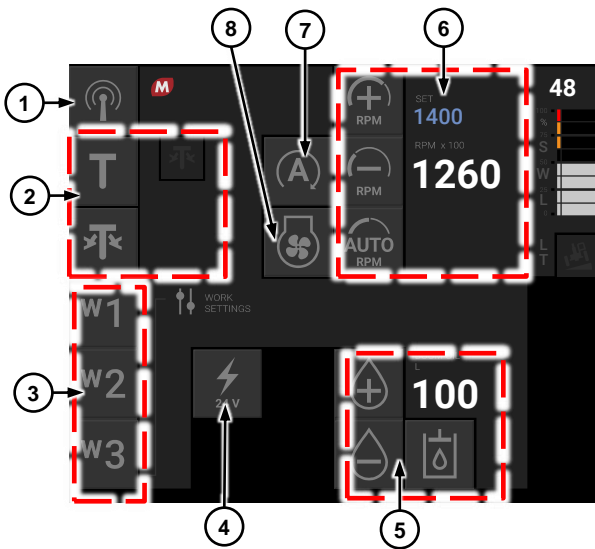

The central portion of the page enables additional functions described below:

- 1- radio control enabling,
- 2- hydraulic rotation lock,
- 3- working mode
- 4- 24V boom head
- 5- continuous hydraulic fluid,
- 6- idle speed/engine control,
- 7- Start & Stop
- 8- Fan reversal

NOTICE

This page may vary depending on the optional functions enabled on the vehicle. Please contact Magni Telescopic Handlers Service in case of lack of adequate description.

Radio control connection



Pressing this button enables, when present (optional), the connection to the radio control to drive the vehicle from the outside for types of work requiring a different viewpoint.

Hydraulic rotation lock

With this function installed on the vehicle, it is possible to lock the turret rotation by lowering the specific pivot by means of a hydraulic system.

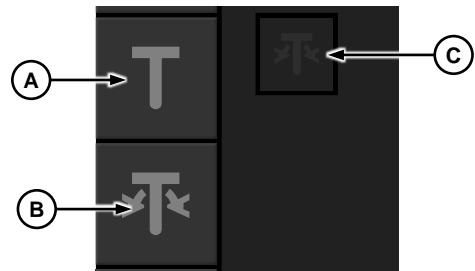

- A. pin up control button
- B. pin down control button
- C. pin position feedback light



CAUTION

This function is only enabled when the cab is positioned within $\pm 2^\circ$ of rotation. Outside this parameter, it is possible to enable the up movement using the grey limit override key.

With the cab positioned as described, press button ① or ② shown above to move the pin as desired.

The ③ light signals the pin position on the display:



pin raised → rotation unlocked,



pin lowered → rotation locked.

NOTICE

With the optional hydraulic rotation lock, these lights are also repeated on the Drive page.

During the pin movement, the operation is signalled graphically with the position indicator  changing colour to orange and with a special text banner, also orange



rotation lock in progress



rotation release in progress



When the up/down movement of the rotation lock is performed, a dedicated green signalling banner is displayed.



If the operation fails, the warning banner is displayed red, in which case check the status of the pin position detection sensors.



Working mode

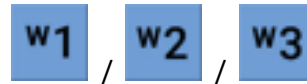

Buttons **W1**, **W2** and **W3**, identify 3 distinct modes of setting the vehicle's movement speeds: for certain operating phases or to move a specific type of equipment, the operator can select a specific setting:

W1: factory standard settings usable with all types of interchangeable equipment;

W2: slowed down hydraulic movement speed settings, can be used with all types of interchangeable equipment and recommended for handling suspended loads (hooks, ropes with hooks);

W3: setting of higher movement speeds selectable only with interchangeable equipment such as shovels or buckets.

NOTICE

Depending on the interchangeable equipment installed, the availability of working modes may vary: this condition is indicated by the specific non-enabled mode crossed out.

NOTICE

During the use of aerial work platforms, these modes are bypassed by specific safety settings.

24V electrical output at boom head



Press this button to enable the power socket (optional) present at the top of the boom for supplying current to the accessories that may be fitted.

Continuous hydraulic fluid

This function enables the flow of fluid to the outlets at the boom head for the use of specific equipment that needs the function: e.g. aggregate mixers.

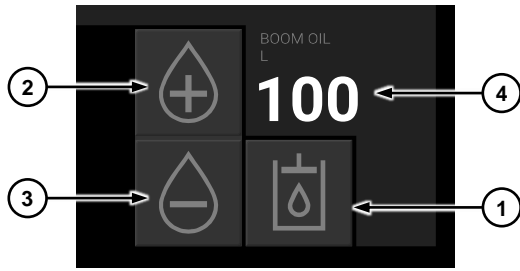

To enable it, press button ①; buttons ② and ③ adjust the flow speed indicated by the numerical value ④ representing the percentage of flow in relation to the maximum flow rate.

Idle speed/engine control

In this portion of the page, the minimum value of the I.C. engine can be selected.

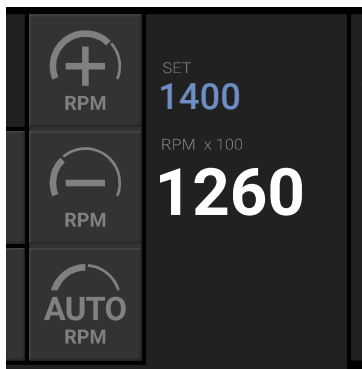

The **AUTO RPM** function enables the automatic increase of I.C. engine speed according to the demand for hydraulic service fluid: with the engine at idle (850rpm) at any hydraulic command given (stabilisers, turret, telescopic boom, etc.) the engine increases the speed supporting the service pump in order to provide maximum efficiency.



The **RPM + /-** buttons allow you to set an idle speed value according to your needs: the set value will be indicated with **SET**; this information, once set, is also shown on the **DRIVE** page together with the tachometer's numerical graphic indicator.



Start & STOP



When enabled, this function allows the I.C. engine to be switched off 1 minute after the last command given to the vehicle.

To restart the engine, press the brake pedal.

Enabling of this function is indicated on the **DRIVE** page by a specific light:



: green indicates active function and function in stand-by with engine running



: orange indicates the function is active and operating with the engine off.



CAUTION

With the function active, when leaving the driver's seat, the engine restart by means of the ignition key is indicated on the display.



CAUTION

In low battery condition, the Start&Stop device is deactivated, allowing the engine to power the alternator and recharge the batteries.

Cooling fan rotation reversal



This function enables the program to reverse the direction of rotation of the cooling fan: this makes it possible to blow air outside the engine compartment to clean the aeration surfaces by removing accidental deposits of material potentially harmful for the equipment.

The inversion sequence involves two minutes of air suction and one minute of expulsion at cyclic intervals of 20 seconds of slowing down of the fan speed in order to protect its mechanism.

Password Pages

Pages protected by password give access to advanced information and/or settings.

NOTICE

The following descriptions on the Password pages may differ from vehicle model to vehicle model depending on the specific configuration.

To enable these pages please contact Magni Telescopic Handlers Service.

Level 1 password:

- clock and 12h/24h format setting,
- multiple function display brightness adjustment,
- cab reading light brightness adjustment,
- management of the automatic change of display pages on the multiple function display,
- management of the language of the texts displayed on the multiple function display,
- management of the value measurement system: metric/imperial,
- management of automatic rear camera signal activation when reverse gear is engaged,
- light/dark lighting management of the multiple function display,
- automatic steering function enabling,
- enabling of the automatic parking brake,
- LIMITS page display enabling,
- enabling of automatic levelling always operational.

Level 2 page:

In addition to the display of Level 1 page data,

- management of access passwords to the Level and Level 2 pages,
- maintenance hour meter management,
- optional TWIN POWER enabling, when present,
- continuous hydraulic fluid function enabling,
- LIMITS page display enabling,
- manual engine speed management enabling,
- stabiliser extension setup function enabling,
- optional WINTER MODE enabling, when present,
- enabling of compulsory closing of stabilisers during translation.

Level 3 page:

In addition to the display of Level 1 and 2 page data,

- calibration management of the vehicle's functional parameters.

System Info page

SYSTEM INFO	
RTM6.22	
0000****	
HMI-APP VERSION	8.8.8.8
HMI-MAIN OS VERSION	8.8.8.8
HMI-RUNTIME VERSION	8.8.8.8
HMI-IP ADDRESS	8.8.8.8
SCU-APP VERSION	8.8.8.8
SCU-SAFEAPP VERSION	8.8.8.8
SCU-OS VERSION	8.8.8.8
SCU-BOOTLOADER VERSION	0
SCU-HARDWARE VERSION	0
LT VERSION	8.8.8.8
LT VARIANT ID	0
MARKET	0
PAR-REV INDEX 1	0
PAR-REV INDEX 2	0
MOTOR TYPE	DEMT2
TRANSMISSION TYPE	DANFOSS PC&C
TRANSMISSION SW VERSION	99999
TRANSMISSION PAR VERSION	99999

This page groups together the master data of the vehicle and its components, both hardware and software: here you can check the name of the vehicle model, its serial number, the type of engine installed, the type of transmission installed, the various versions of software installed to manage the control and diagnostic units.

Air vents

In the cab, there are air vents adjustable in orientation located in front of the driver to the right of the steering column on the hat rack located behind the seat, and at the base of the entry door pillar; they are all adjustable in air flow and temperature in the *Commands* page of the display, as described above.

There is also a windscreen-specific air diffuser located in the crossbar that incorporates the front windscreen wiper.

Service compartments for the vehicle driver

In the cab, there are service compartments to the right of the driver's seat:

- document pocket ①,
- mobile/tablet pocket ②,
- beverage holder ③.

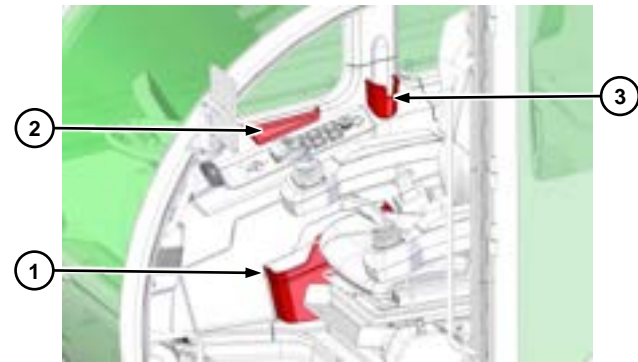

Safety keys container

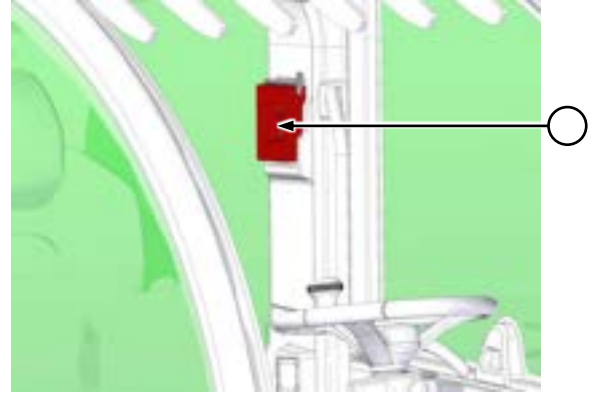

The container for the keys used for excluding the safety systems is fitted on the left jamb inside the driver's cab.

The container contains two keys:

- key for exclusion of the rollover protection safety systems, with metallic grip;
- key for exclusion of the lift platform safety systems (optional), with plastic grip.

Should it become necessary to use the keys enclosed inside, take the hammer located above the container and break the protective glass.

Once the safety procedure is complete, replace the key(s) and restore the protective glass.

Vehicle radio

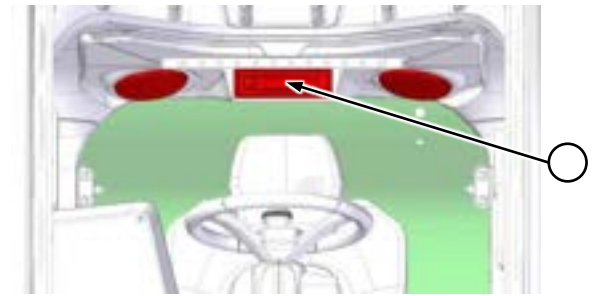

The vehicle radio is present on the rear covering of the cab behind the operator's head. The speakers are present between the driver's seat and the rear window. The radio is included in the standard vehicle supply. For operation of the radio installed, refer to the Instruction Manual included in the package delivered with the vehicle.

Reading light

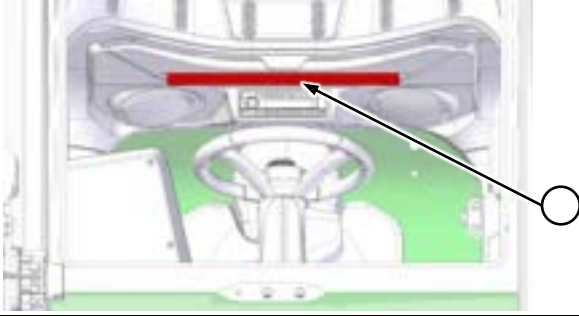

A ceiling light is located on the cab roof panel: this switches on automatically when the cab door is opened and switches off when the engine is started.

It can be activated for document reading by means of the appropriate button on the *Commands* page described above and shown here.

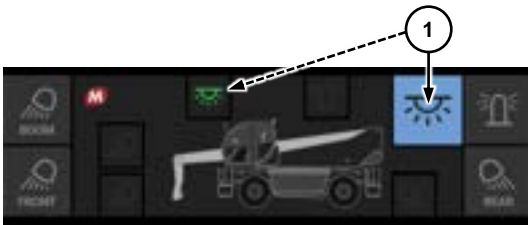

Sunshade

Positioned above the driver's seat is the retractable sunshade ①: this, when grasped by the handle, can be pulled out of its seat and extended in two different stages, ② and ③, depending on the driver's needs.

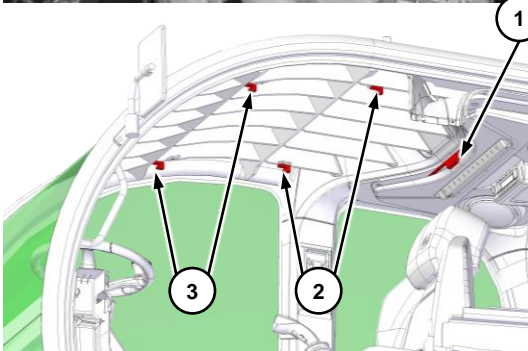
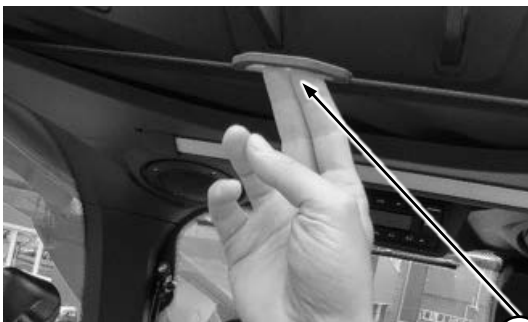

Radio control battery charger

In the lower portion of the left-hand pillar of the cab is the battery charger for the radio control (when present in the vehicle)

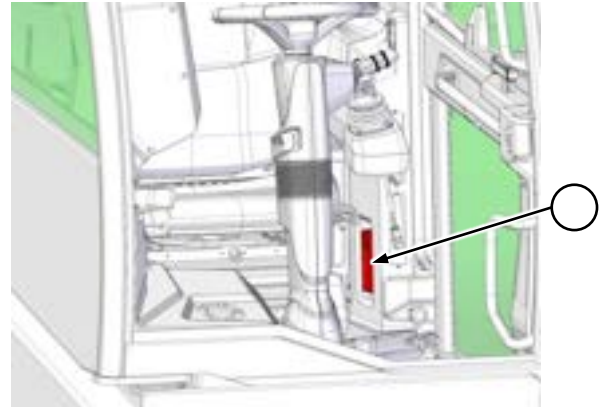

Radio control housing (Optional)

Behind the driver's seat there is a place to store the radio control when present and not in use.

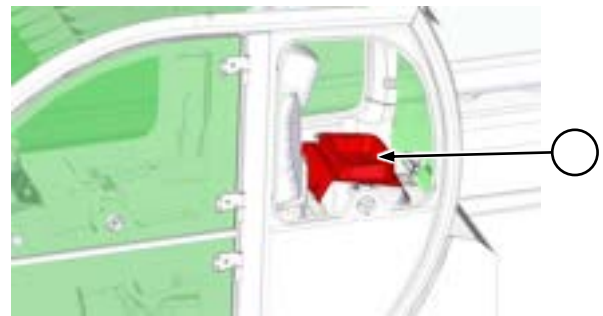

External elements

Work and emergency lights

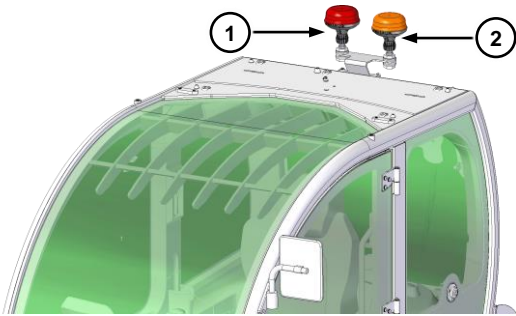

Above the cab there are:

- the red beacon ① which is activated when the limiting working conditions are reached and warns people outside of a possible dangerous situation,
- the orange beacon ② with the function of signalling a moving vehicle and activated from the multiple function display, as described above.

Rear view mirrors

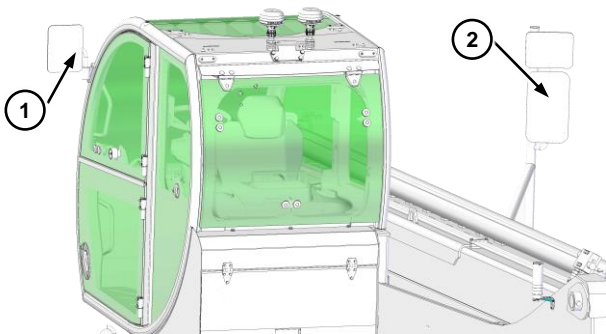

The vehicle is equipped as standard with three rear-view mirrors: one on the left ①, installed directly on the cab, and two on the right ② installed on a support structure bolted to the right side of the vehicle turret.

The rear view mirrors on the right make it possible to simultaneously display the rear area and the area of the ground adjacent to the side of the vehicle.



CAUTION

Adjust the rear view mirrors before operating the vehicle to give the operator maximum visibility of the area adjacent to the vehicle.

Headlights

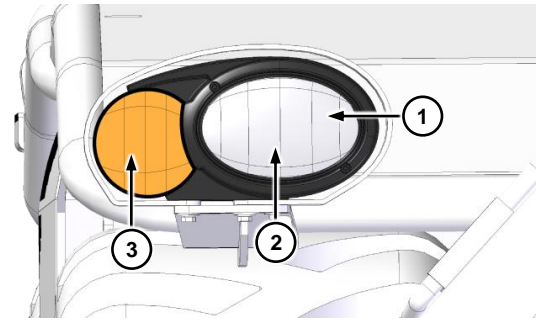

The headlights consist of the following lights:

- Position light ①,
- Low/high beam ②,
- Direction indicator ③.

Selection is controlled by means of the light switch lever on the steering column in the cab.

Tail lights (Optional)

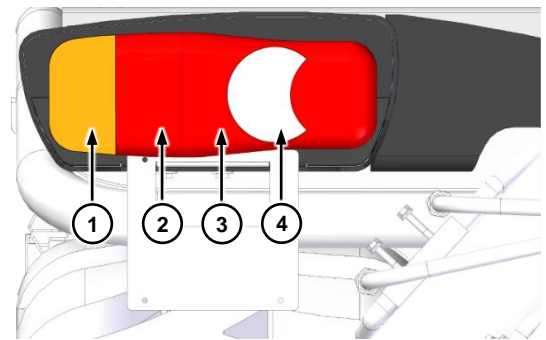

The tail lights unit consists of the following lights:

- Direction indicator ①;
- Stop light ②;
- Position light ③; (+ licence plate light for left light cluster);
- Reversing light ④.

The selection for position lights and direction indicators is controlled by the light switch lever on the steering column in the cab. The STOP light is activated by pressing the brake pedal of the vehicle; the reverse light is activated by means of the FNR button on the right joystick in the cab.

Additional cab work lights

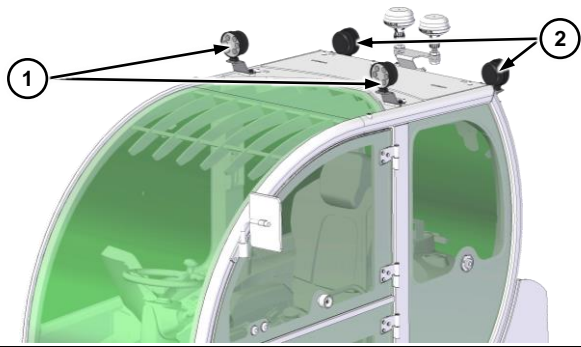

The vehicle can be fitted with additional LED work lights positioned above the cab: these, two at the front ① and two at the rear ②, are managed on the *Commands* page as described above and shown here.



Additional work lights on the telescopic boom (Optional)

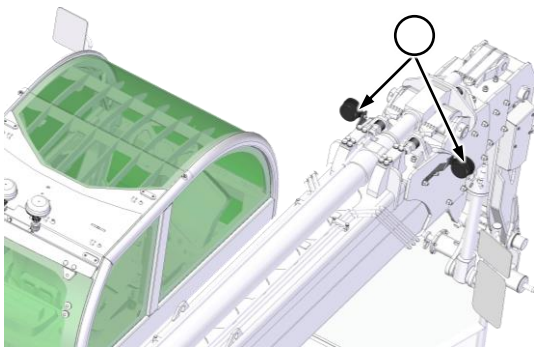

The vehicle can be equipped with additional LED work lights positioned at the end of the telescopic boom frame: these are managed on the *Commands* page as described above and shown here.

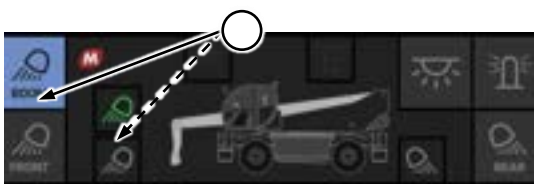

Shear pin housing for interchangeable equipment

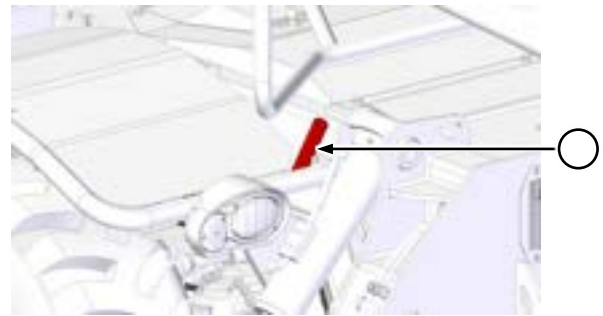

The housing of the shear pin for the quick-fit coupling of the equipment is present in the front part of the vehicle chassis near the mudguard.



CAUTION

The shear pin must also be on the vehicle so as to be available when required.

Always fit the shear pin in its housing when not in use.

If placed in an unsuitable part, the shear pin may get jammed between the moving parts of the vehicle, causing serious problems.

Anchoring points

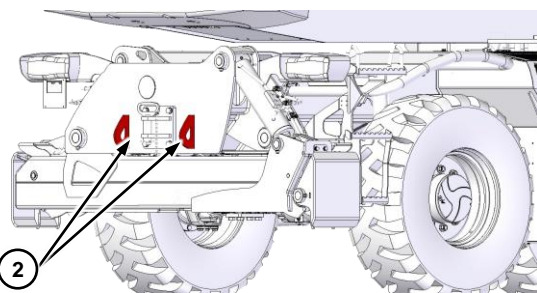
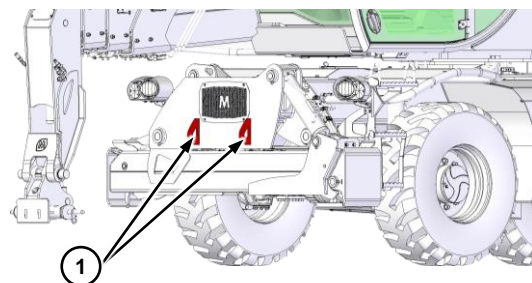

The vehicle is provided with four anchoring points, in the front part of the chassis ① and in the rear part ②, all marked by a specific sticker:

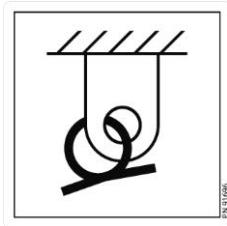

WARNING

Unless otherwise indicated in this Manual, never fix anchoring devices to other parts of the vehicle.

Tow hook

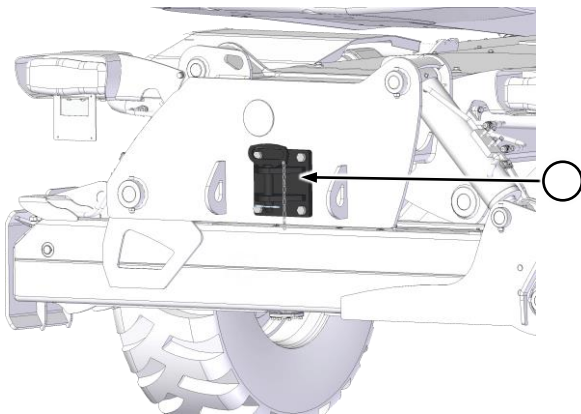

The vehicle is provided with a tow hook positioned in the rear part of the chassis.

When using the hook, ensure that the pin is properly secured by the attached steel chain-bound safety cotter pin.

CAUTION

Do not tow trailers with a mass greater than that indicated by the specific sticker on the hook for each vehicle model.

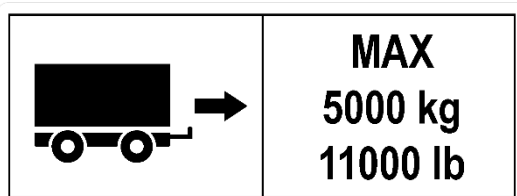

WARNING

Do not connect towing devices other than the tow hook as anchoring points to parts of the vehicle.

WARNING

The towing operations must always be carried out by personnel appropriately trained in compliance with the laws in force.

Quick-fit coupling for the equipment

The vehicle is equipped with an interface, hereafter referred to as a *quick-fit coupling*, to be combined with interchangeable equipment with specific functions: fork attachment plates, winches, lifting hooks, aerial work platforms, etc.

This quick-fit coupling, depending on the end customer's specifications, can be of two types: "I" or "U".

"I" and "U" couplings

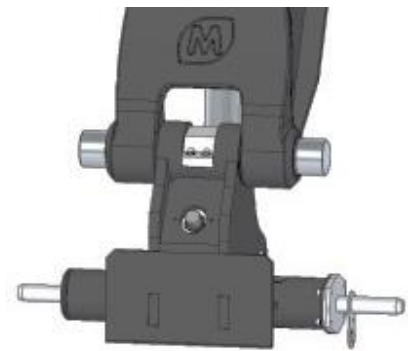

The "I" coupling (with Magni Telescopic Handlers patent) is designed to be more rigid, more compact, in comparison with those of competitors and is designed solely for equipment designed and produced by Magni Telescopic Handlers S.r.l.. (or licensed) with similar coupling.

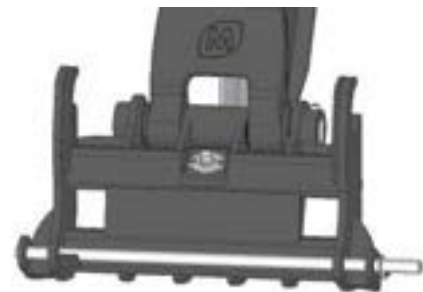

The "U" coupling is designed to be fitted with equipment designed and constructed by Magni Telescopic Handlers Srl with a similar coupling, just as it can also be fitted with equipment designed and constructed by other manufacturers (e.g. Manitou Costruzioni Industriali), subject to checking and approval of installation conformity by Magni Telescopic Handlers S.r.l.

Secondary access ladder

For vehicle models with “scissor”-type stabilisers and driving cab in forward position, there is a secondary access ladder located to the rear right of the slewing variable-reach truck: this is used for getting in/out of the cab when it is above the rear axle, facilitating operations without the need for realignment.

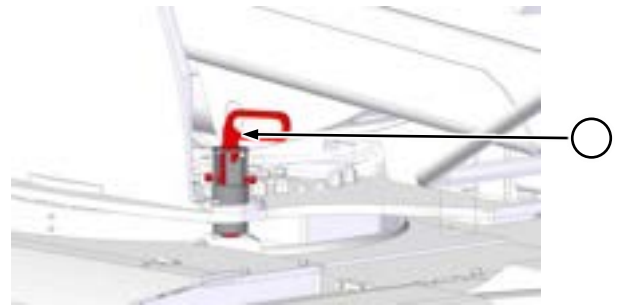
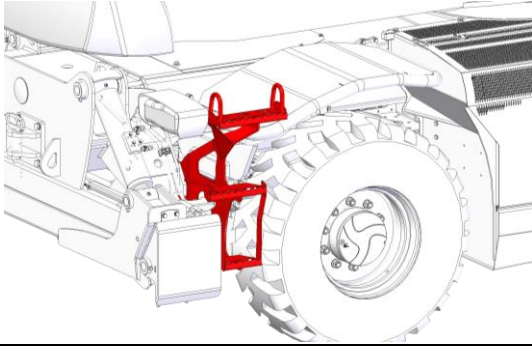

Grasp the pin using its handle. Lift and rotate it anti-clockwise. Push the pin in downwards all the way.

In the presence of hydraulically actuated rotation pin, both positioning (engaged/disengaged) and movement can be checked/managed through the multiple function display in the cab.



WARNING

It is strictly forbidden to use this ladder for any purposes other than those described, except for maintenance operations.

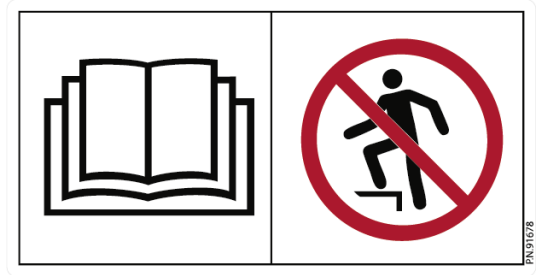

Turret rotation lock pin

The turret rotation lock is located at the front right of the turret: this can be either manual or hydraulically actuated, operation explained above in the multifunctional display section.

Before starting the work phases, check the pin position: if the desired result is not achieved with the turret rotation command, check that the rotation pin is not engaged.

To unlock it, grip it using the handle on top, remove it from its seat and lock it in place by turning it clockwise.

To insert the mechanical block, align the turret so that the pin is aligned with its seat.

Check the turret alignment on the cab display, maximum tolerance is $\pm 2^\circ$.

OPERATING TECHNIQUES

Before using the vehicle

NOTICE

Take note of what is already contained in the “*Correct Use*” and “*Reasonably Foreseeable Misuse*” sections



CAUTION

Operators using the vehicle must be trained and must be familiar with all its working aspects. The operator must obtain a licence or certificate if required by the regulatory standards in force. If the vehicle is used on public roads, a regular driving licence is required in accordance with the laws in force.

Always shut the cab door. Lock the windows and/or door open or closed. Clean all windows to ensure perfect visibility.

Check the condition of the seat belt and fixing points. Replace all visibly damaged and worn parts. Replace the entire safety belt after 3 years irrespective of wear. Do not use extensions.

Before starting the I.C. engine, check the level of all the fluids: engine oil, transmission oil, hydraulic fluid, coolant, fuel, urea (if present).

Check under the vehicle for oil, fuel or coolant leaks.

Make sure all the hoods are closed and all guards are installed correctly on the vehicle.

Adjust the seat so that the pedals can be pressed completely while sitting correctly. Adjust the steering column inclination to ensure a comfortable posture and easy access to all the controls.

Make sure the lighting on board is adequate for the working conditions, and that all the lights are working correctly.

Check to make sure the horn, signalling lights and all the alarm devices work correctly.

Adjust the orientation of the rear-view mirrors to best cover the visual area around the vehicle.

Check the state and wear of the tyres. If necessary, adjust the inflation pressure.

Work area



WARNING

Before each operational phase check that the ground where you are working is capable of supporting the weight of the vehicle and the maximum load-bearing capacity according to the equipment installed.



CAUTION

Check the specific manual of the interchangeable equipment in use for any special requirements.

Weather conditions

Always check the weather conditions before and during work phases: if visibility is poor, suspend work.

In the event of thunderstorms with lightning, suspend work.

Using the vehicle in windy conditions

The variation in wind speed can lead to many problems such as loss of vehicle stability, swinging load, reduced visibility due to rising earth, dust, leaves, etc.

Unfavourable factors for vehicle use are:

- Location of the site: the aerodynamic effect of buildings, trees and other structures can lead to an increase in wind speed.
- The height of the extended boom: the higher it extends vertically, the more the wind speed is perceived.
- The load area: the more area the load occupies, the more it is affected by the wind force.

Near gale

Magni telescopic handlers can be used up to a wind speed of 36 km/h equal to 10 m/s (5 on the Beaufort scale) measured on the ground.

Wind-Chill effect

At a temperature of 10°C (50°F), a wind speed of 32 km/h (8.9 m/s) makes the exposed parts of the body feel a temperature of 0°C (32°F).

The higher you climb, the more the wind speed increases and the more the feeling of a drop in temperature increases.



WARNING

In the presence of strong wind (5 on the Beaufort scale) never lift loads with a surface area of more than 1 m².

Below is a table of the Beaufort scale in order to be able to roughly determine the wind speed and assess the possible suspension of work

Climatic conditions of use

It is recommended to always take into account the climatic and atmospheric conditions of the place of vehicle use.

The vehicle is designed for use in different temperature, humidity and altitude conditions. However, it is still advisable to observe the values given in the technical tables (*Environmental Data*).

For use in extreme cold conditions, it is necessary to install a few additional devices to help with start-up (e.g. coolant, fuel, engine oil and/or hydraulic fluid heater, higher capacity batteries, etc.)

Contact your dealer or after-sales service for technical support in this regard.

Always take into account the climatic and atmospheric conditions of the place of use.

Using the vehicle in snowy conditions



WARNING

Be careful to use the vehicle and proceed with great caution in the event of snow falling and/or snow on the ground as it hides obstacles, buries objects, it can cover holes / excavations / ditches, etc.

It is strictly forbidden to operate if the amount of snow is such that the obstacles and dangers along the route cannot be clearly distinguished.

In case of snow be very careful not to move away from the roadside; anything buried along the edge of the road could cause the vehicle to overturn or damage some components.

Surfaces covered with snow or ice are extremely dangerous, operate with great caution and reduce the vehicle speed as much as possible.

In case of snow operate with great caution, if the vehicle sinks into the snow there is a risk that it may overturn or remain buried and/or trapped.

Be very careful when moving on icy ground; as the temperature increases, the base becomes loose and slippery.

BEAUFORT WIND SCALE					
force	speed (km/h)	speed (mph)	speed (m/s)	wind type	wind effects
0	0 - 1	0 - 1	> 0.3	calm	smoke rises vertically;
1	1 - 5	1 - 4	0.3 - 1.5	light air	wind causes smoke to drift.
2	6 - 11	5 - 7	1.6 - 3.3	light breeze	leaves rustle.
3	12 - 19	8 - 11	3.4 - 5.4	gentle breeze	leaves and twigs constantly agitated.
4	20 - 28	12 - 18	5.5 - 7.9	moderate breeze	the wind raises dust, dry leaves, small tree branches constantly moving.
5	29 - 38	19 - 24	8 - 10.7	fresh breeze	small trees in leaf begin to sway.
6	39 - 49	25 - 31	10.8 - 13.8	strong breeze	large branches constantly moving, hissing between the telegraph wires.
7	50 - 61	32 - 38	13.9 - 17.1	near gale	entire trees moving, difficulty in walking against the wind.
8	62 - 74	39 - 46	17.2 - 20.7	gale	broken branches, walking against the wind is impossible.
9	75 - 88	47 - 54	20.8 - 24.4	strong gale	shingles and tiles blown away.
10	89 - 102	55 - 63	24.5 - 28.4	storm	seldom experienced on land, trees uprooted, considerable damage to dwellings.
11	103 - 117	64 - 73	28.5 - 32.6	violent storm	rare, severe devastation.
12	beyond 118	74 +	32.7 +	hurricane	destruction of buildings, constructions etc..

Road circulation



WARNING

Check, before proceeding on public roads open to traffic, that the vehicle is properly approved for the country in which it is to be used.

The circulation on the road with accessory mounted in the head of the boom is allowed only if expressly indicated in the technical attachment of the road approval.

Contact Magi Telescopic Handlers Service for more information.



WARNING

In the event of regular type approval, check that the vehicle in use has all the specifications set out in the relevant registration certificate and is operated in accordance with the prescriptions therein.



WARNING

While travelling on roads, only use the mode with two front steering wheels.

Travel with the telescopic boom completely retracted and lowered as far as possible.

Make sure that the quick-fit coupling is high enough from the ground.

During road circulation it is mandatory to enter the mechanical lock of the turret rotation.

Parking the vehicle

Always park the vehicle on a flat surface.

Always apply the parking brake.

Set the reversing switch to neutral N,

Position the vehicle on stabilisers or, when on wheels, place suitable wheel chocks.

Switch the engine off.

Do not leave loads suspended.

Do not park the vehicle with a load hanging from the equipment.

If the vehicle is to remain parked for a long period, protect it from atmospheric agents.

Before stopping the engine let it run at minimum for a few minutes. Immediately stopping the engine after it has been working under load can cause overheating and premature wear of some of the components.

Retract the telescopic boom and lower it.

Before leaving the vehicle, check all the locks:

- engine compartment;
- fuel cap;
- cab door;
- additional lockable equipment.

For long-term stops, turn the battery cut-off switch in the engine compartment to switch off the main circuit. This will prevent a short circuit and damage to the batteries and will preserve the charge from abnormal power draws.

NOTICE

For engines meeting Stage V anti-pollution standards, wait at least 5 minutes after the engine is switched off before disconnecting the main electrical circuit.

This compliance preserves the after-treatment system operating with the urea-based additive (AdBlue®).

Install a waterproof covering to protect the vehicle from atmospheric agents if it is to remain unused for a long period.

Interchangeable equipment installation



DANGER

If fitted incorrectly, an attachment can suddenly detach from the vehicle during operation. This can cause injury or even death.

Do not operate the vehicle without the shear pin fitted in the quick-fit coupling.

Position the attachment on a stable level surface. Make sure there is sufficient space for operation. Check the attachment to make sure it is clean and intact before fitting it.

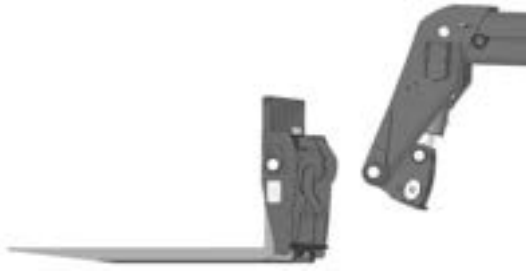

Bring the vehicle perpendicular to the equipment with the boom completely retracted and lowered. Retract the slewing cylinder to make hooking easier. Stop the vehicle with the quick-fit coupling about a metre away from the equipment. Move the reverse gear lever to the neutral position and apply the parking brake.



Extend the telescopic boom slowly, checking the alignment until the quick-fit coupling is engaged, then raise it to fit the accessory. Raise the equipment by a few centimetres off the ground to ensure the elements fit in perfectly.



Rotate the quick-fit coupling until fully coupled with the accessory.

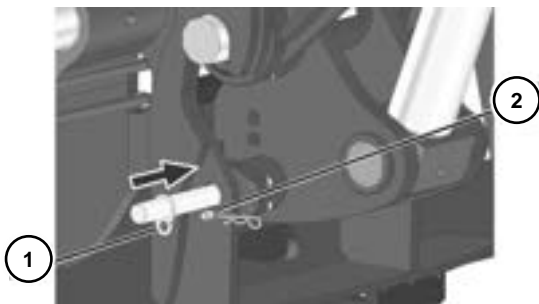

Take the shear pin ① from its housing on the vehicle chassis and insert it in all the way, taking care to align the hole. Complete the procedure by inserting the cotter pin ② in the hole to prevent the shear pin from coming loose accidentally.



DANGER

It is forbidden to operate without the locking pin secured with interchangeable equipment installed.



DANGER

In the event of problems during coupling due to deformations of the equipment structures or the shear pin, it is strictly forbidden to proceed with the use of the vehicle and the equipment itself until the problem is resolved.

In the case of interchangeable equipment requiring hydraulic and/or electrical functions, connect the respective connectors to those at the head of the telescopic boom.



WARNING

The hydraulic connections are marked with metal labels: respect the couplings. Incorrect coupling can cause malfunctioning of the equipment by reversing the commands given.

Equipment confirmation

Magni Telescopic Handlers are equipped with an RFID (Radio Frequency Identification) equipment recognition sensor installed in the centre of the quick-fit coupling: this system allows the vehicle's software to recognise, at the instant of coupling, the type and model of equipment present at the head of the boom.

Correct recognition enables in-cab or specific load diagram with relevant working areas and operating limits.

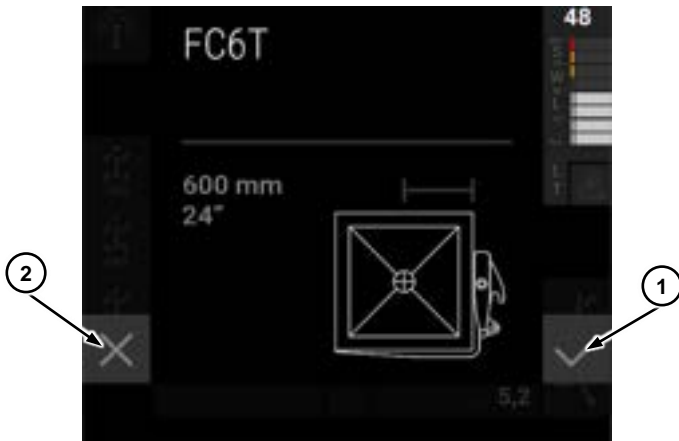

Confirmation of the equipment is done via a request on the display by means of an active banner: the example above shows the recognition of a fork attachment plate with a capacity of 6t; if the equipment on the boom head is correct, the pairing must be confirmed by pressing button ① ✓.



CAUTION

In the event of non-recognition or incorrect recognition, press button ② X: in this condition the vehicle is operational with limited functions (NO TOOLS) for the handling of unrecognised equipment in the construction site area only.

Check the condition of the RFID sensor at the head of the boom and the respective tag mounted on the unrecognised equipment.



DANGER

It is strictly forbidden to work with equipment that is not recognised by the vehicle software while operating with the limit disabling key active.

Removing the equipment

Position the vehicle on a stable level surface. Make sure there is sufficient space for operation. Move the reverse gear lever to the neutral position and apply the parking brake.

Remove the cotter pin and remove the shear pin. Fit the shear pin in its housing on the vehicle chassis.

Lower the telescopic boom and rest the equipment gently on the ground. Rotate the quick-fit coupling downwards to make it easy to detach the equipment.

Lower the telescopic boom to separate the slewing variable-reach truck from the accessory. Retract the boom completely to separate the quick-fit coupling from the equipment.

Clean the equipment thoroughly. Grease all the pins and movable parts to protect them from corrosion and wear. Remove excess grease to prevent accumulation of dirt.

Always keep the equipment protected from atmospheric agents. Rest the equipment on a support raised off the ground and protect it with a waterproof cover if necessary.

Hydraulic shear pin

With this configuration, a hydraulic jack inside the quick-fit coupling locks the interchangeable equipment. This operation can be managed from the cab without getting off for manual pin insertion.

For vehicles equipped with hydraulic safety pin, regardless of "I" or "U" model, a specific spring-operated actuation button with dedicated graphics is available on the dashboard to the right of the seat.



To lock the equipment, when quick-fit coupling and interchangeable equipment have been correctly coupled, press the dedicated button on the dashboard and operate the left joystick hydraulic command by rotating the roller forward.

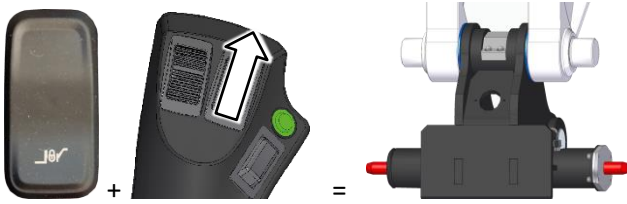

Pin open → equipment locked

To unlock the equipment, press the dedicated button on the dashboard and operate the left joystick hydraulic command by rotating the roller backward.

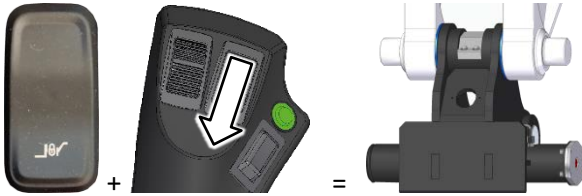

Pin closed → equipment unlocked

List of compatible accessories

- Winch
- Bucket (e.g. for concrete)
- Jib
- Lattice boom with winch
- Hook
- Waste buckets
- People carrier aerial work platform
- Clamp (with different applications)
- Fork attachment plate
- Branch cutter

These accessories are approved for use on the telescopic handler models mentioned in this manual. Do not use accessories that are not approved by the manufacturer. Contact your dealer for more information on approved accessories.

NOTICE

The list of compatible equipment is subject to change without notice.

Approved equipment



WARNING

The use of interchangeable equipment not approved on the vehicle by Magni Telescopic Handlers S.r.l. may result in injury or death.

Before installing interchangeable equipment on the vehicle, make sure it has been approved by Magni Telescopic Handlers S.r.l., and that the corresponding load charts are present in the vehicle management software.

The code of the interchangeable equipment manufactured by Magni Telescopic Handlers S.r.l. is stamped on its identification plate. To establish whether interchangeable equipment is approved, contact the dealer or the Support Service directly.

Some interchangeable equipment produced by companies other than Magni Telescopic Handlers S.r.l. can be adapted for fitting on the vehicles described in this Manual. Contact your dealer to know if your interchangeable equipment can be adapted for assembly on your vehicle.

If the interchangeable equipment is suitable and before proceeding, the equipment and the vehicle must be sent to the dealer for the required modifications and tests. A document confirming proof of the combination will be issued at the end of the procedure.



CAUTION

It is forbidden to use interchangeable equipment without the EC Declaration of Conformity and the Use and Maintenance Manual. It is also forbidden to use any interchangeable equipment on your vehicle if the EC Declaration of Conformity does not confirm its compatibility.

Handling of loads

During load handling operations always display the load control page to keep the percentage indicator and load chart under control.



DANGER

If the load status indicator is in alarm, make only the unloading movements in the following order:

- retract the telescopic boom as far as possible;
- lift the telescopic boom if necessary;
- lower the boom to deposit the load.
- never try to extend the telescopic boom when the load indicator shows an alarm signal.

Centre of gravity of the load

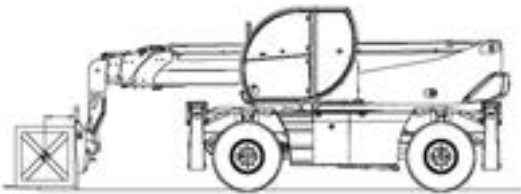

Never try to lift loads heavier than the rated capacity of the vehicle.

Before lifting a load, it is necessary to know its weight and the relative centre of gravity position. The longitudinal position of the centre of gravity varies according to the type of interchangeable equipment attached to the vehicle.

Refer to the technical specifications in the interchangeable equipment's user manual to know the centre of gravity used.

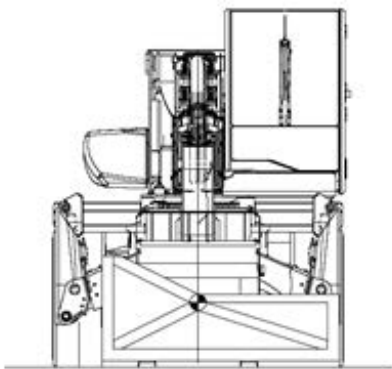

In case of irregular loads, determine the centre of gravity in the transverse direction to the vehicle before making any movement.

For loads with mobile centre of gravity, such as tanks containing liquids, it is necessary to take into account the load oscillations and take utmost caution in handling to avoid excessive shifting of the centre of gravity.

Picking up a load from the ground with fork attachment plate



DANGER

During manual adjustment of the forks or other parts of the interchangeable equipment there is a crushing hazard for the limbs. This can lead to serious injuries.

Take the utmost care while handling the load.

Manually adjust the width of the forks so that these can be inserted in the openings in the pallet at the base of the load. If there is no pallet, assess the width of the blades to give the load maximum stability.

Incline the quick-fit coupling so that the forks are not in the horizontal position. Approach the load slowly with the boom lowered and insert the forks under it.

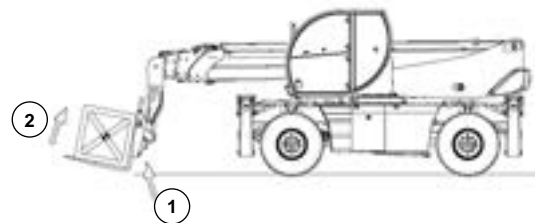

Apply the parking brake and set the reverse gear lever in the neutral position.

Lift the load ① slightly and incline the quick-fit coupling upwards ② to make the load stable. Take care to avoid modifying the load balance negatively (tipping forward).

Taking a load from a height with the vehicle on tyres with fork attachment plate

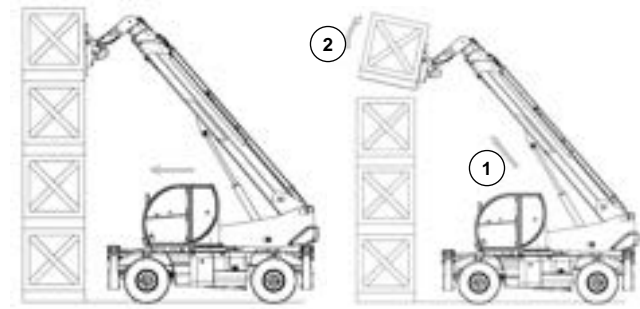

Put the vehicle perpendicular to the designated load. Make sure the forks pass under the load and are properly adjusted to the load.

Bring the vehicle near the load slowly with the forks in the horizontal position. Move carefully to insert the forks under the load. The forks must enter the pockets of the pallet all the way with precision. Take care to avoid knocking against the load.

Apply the parking brake and set the reverse gear lever in the neutral position.

Lift the load ① slightly and incline the quick-fit coupling upwards ② to make the load stable, taking care to avoid modifying the balance negatively.

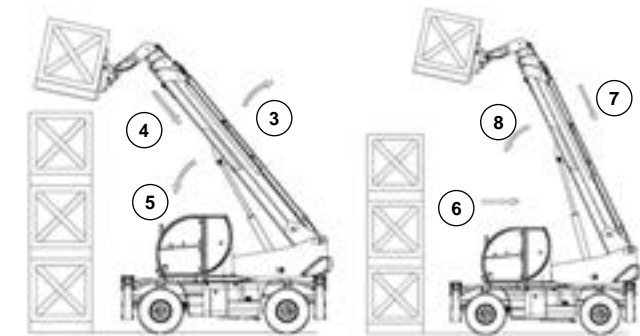

If possible, lower the load without moving the slewing variable-reach truck. Lift the boom to move the load away ③, retract the telescopic boom ④ and lower it to bring the load to the transport position ⑤.

If the load cannot be lowered without shifting the vehicle, move gently in reverse ⑥ and with utmost care to move the load away. Retract the telescopic boom ⑦ and lower it ⑧ to bring the load to the transport position.

Bring the load to the transport position

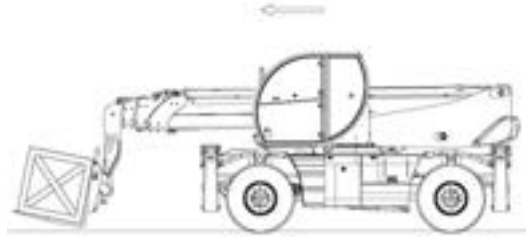

Every time reference is made to the “transport position” in this Manual, it means the configuration of the vehicle is as described below:

Telescopic boom completely retracted;

Quick-fit coupling rotated slightly upwards;

Telescopic boom lowered in such a way as to keep the load approx. 300 mm (11.8 in) off the ground.

For specific cases, the transport configuration is indicated in the “Pick & Carry” chart in the relevant section of the interchangeable equipment’s Use and Maintenance Manual.

Placing a load at a height with the vehicle on tyres

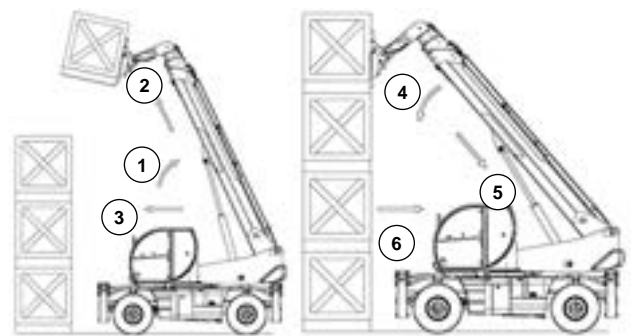

After picking up the load, lift ① and extend ② the telescopic boom to position the load above the area in which it is to be deposited. Move the telescopic handler close to the area where it is to be deposited ③.

Apply the parking brake and set the reverse gear lever in the neutral position.

Rotate the quick-fit coupling downwards to position the load horizontally ④. Lower and retract the boom ⑤ with slow movements to release the load in its place.

Release the parking brake and set the reverse gear lever in reverse. Release the forks lowering the telescopic boom slightly and moving slowly in reverse ⑥.

Picking up a cylindrical load without pallet with fork attachment plate

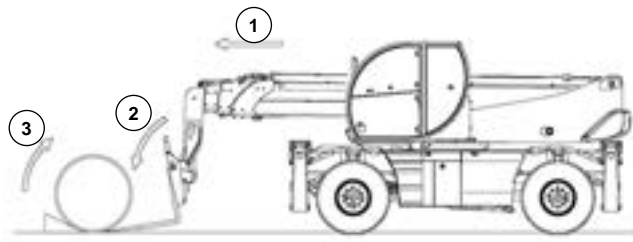

Position the vehicle at right angles to the load. Approach the load with the telescopic boom completely lowered and retracted. Apply the parking brake and set the reverse gear lever in neutral. Incline the quick-fit coupling downwards ①. Extend the telescopic boom slowly ② and at the same time rotate the quick-fit coupling upwards to insert the forks under the load ③.

If the operation is found to be difficult, insert a chock behind the load, to prevent it from shifting while the forks are being inserted.

Moving the centre of gravity

Before picking up a load, it is necessary to know its mass and centre of gravity.

The position of the centre of gravity is indicated on the dimensional drawings and on the load charts in the Use and Maintenance Manuals of the individual accessories.

During operation, the slewing variable-reach truck is subjected to a number of stresses that can affect its stability and therefore its safety.

The objective of greater operational safety is achieved by complying with the balancing principle, which entails operating without compromising the longitudinal and transverse balance of the slewing variable-reach truck, in order to prevent the causes that may cause it to overturn.

For loads with a movable centre of gravity (e.g. liquids), possible variations in the centre of gravity must be taken into account to determine the load volume to be handled.



DANGER

It is forbidden to handle a load exceeding the actual capacity specified on the corresponding load chart in the Use and Maintenance Manual of the individual accessory used.

Operate with the utmost caution and care to limit such variations as much as possible.

Visibility

When driving the vehicle, it is mandatory to remain particularly vigilant especially in its immediate vicinity due to the possible presence of people, animals, obstacles, etc.

Here are a few useful recommendations to have, and maintain, good visibility around the vehicle:

- Make sure you always have a good view from the cab (clean windows, sufficient lighting, rear view mirror adjusted, etc.).
- Always try to have a good view of the route, with direct vision and indirect vision (using the panoramic rear view mirrors) to check for the possible presence of people, animals, holes, obstacles, changes in slope, etc.
- Visibility, on the right side, may be reduced when raising the boom, so make sure you have a good view of the route before raising the boom and proceeding with operations.
- If visibility while driving is insufficient, ask for the support of a person on the ground to provide signals
- The slewing variable-reach truck's signalling systems and lights must be suitable for its conditions of use. The vehicle's standard lighting might not be enough for use in environments that are poorly lit or at night.

Traversing over sloping ground



WARNING

Working with the vehicle on sloping ground can cause overturning or slipping. Move forward and brake gently taking the necessary precautions.

Always move in a straight line to climb up or down a slope.

Always use the parking brake when placing or lifting a load on a slope.

**DANGER**

Do not move crosswise or horizontally along the slope: risk of tipping over.

When travelling on sloping routes, whether uphill or downhill, turn the lifting accessory downstream for empty movements and upstream for movements with a load.

It is strictly forbidden to move with the load facing downstream on a downhill slope, because it would seriously compromise the stability of the load and the slewing variable-reach truck.

If you must go down the slope with a load, do so in reverse gear with the load positioned upstream.

If you must go up the slope with a load, do so in forward gear with the load positioned upstream.

Please contact your dealer or the Magni Telescopic Handlers Service Department for technical support.

INFORMATION REGARDING TRANSPORT

Shipping the vehicle

Make sure the total weight of the vehicle and transport vehicle comply with the standards and regulations in force in the countries along the route.

Ensure that the road chosen has vertical and horizontal margins suitable for the transport vehicle with the vehicle loaded on it.

Before loading the vehicle, remove all slippery material from the transport vehicle, railway carriage or loading ramp.

Before loading the vehicle, always block the wheels of the transport vehicle or railway carriage with chocks.

The boom must be completely retracted and lowered, until the quick-fit coupling or equipment come to rest on the transport vehicle.

The dimensions and weights for shipping a standard vehicle are shown in this Use and Maintenance Manual in the technical specifications.

Lifting the vehicle



DANGER

Always check the condition of lifting elements such as ropes and chains.

Check that the lifting equipment has adequate capacity to lift the vehicle.

The weight and dimensions of the vehicle can be found in the specific section *"Technical Data"*

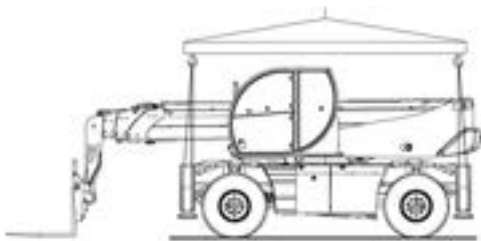

For vehicles with pivoting stabilisers, lower them to a horizontal position and wrap them with straps for lifting purposes as shown above.

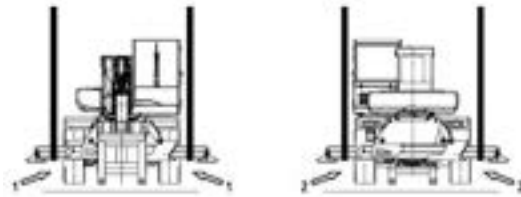
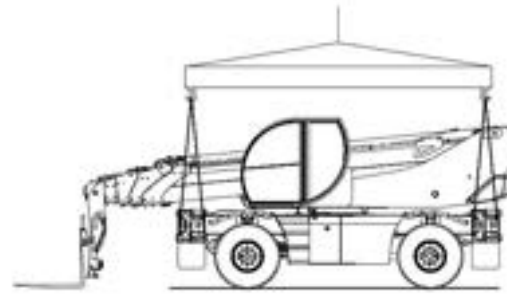

For vehicles with "scissor"-type stabilisers, extend them by the minimum necessary amount and wrap them with straps useful for the lifting sling as shown above.

NOTICE

These instructions are referred to on the vehicle with a special warning sticker placed on all stabilisers.

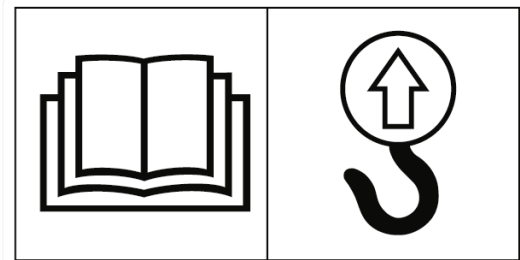

Anchoring the vehicle for transportation



DANGER

Always check the condition of anchoring elements such as ropes and chains.

Check that the transport equipment has adequate capacity to transport the vehicle.

The weight and dimensions of the vehicle can be found in the specific section *"Technical Data"*

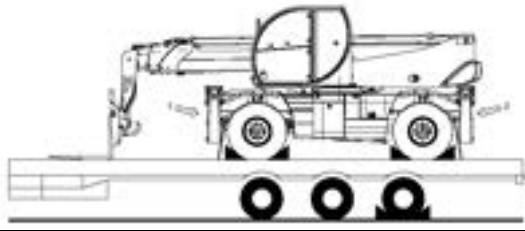

Install anchoring devices approved for the weight of the vehicle with equipment. Fix the anchoring devices at the four points indicated.

Block the front and rear wheels of the vehicle with chocks. Insert the wedges from both sides of each tyre.

Apply the parking brake and set the reverse gear lever in neutral.

Make sure the boom is completely retracted. Make sure the boom is lowered and the equipment rests on the surface of the transport vehicle.

Stop the engine and remove the ignition key from the switch. Get out of the vehicle and close all windows, doors and compartments.

If in doubt, contact your dealer for information and assistance.

NOTICE

The vehicle's anchorage points are marked on the vehicle by special warning stickers.

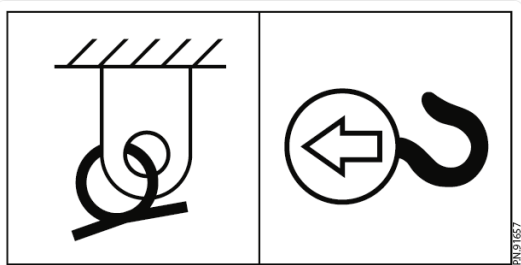

Towing the vehicle

DANGER

Towing the vehicle is a particularly delicate manoeuvre that can create high risks for the operators involved in the operation.

It is recommended that repairs be carried out on site.

WARNING

Towing the vehicle using an incorrect procedure can cause very serious accidents.

Follow the instructions given below to tow the vehicle correctly.

Before disengaging the negative brake manually, block the vehicle to prevent its movement.

Only tow the vehicle for short distances and in any case not longer than 500 m (1640 ft) at a speed not exceeding 5 km/h (3.1 mph). If the vehicle is to be transported for longer distances and at higher speeds, use a suitable transport vehicle.

Before towing the vehicle, retract and lower the telescopic boom completely and remove the load.

Do not use chains or cables for towing the vehicle.

It is mandatory to tow the vehicle using a rigid tow bar compatible with the mass to be towed.

Make sure the rigid tow bar is in good condition and has a nominal carrying capacity 1.5 times the weight of the vehicle to be towed.

Switch on the hazard lights.

Mechanical brake release

Following are instructions for mechanically releasing the brake system after a hydraulic failure.



WARNING

Before carrying out any work on the brake release, it is mandatory to place chocks under the vehicle's wheels to prevent accidental movements.

Go under the vehicle near the front axle. Completely loosen the lock nut ① then screw in the adjusting screw ② as far as it will go to release the brake with negative control. Repeat the procedure on all four screws on the axle.

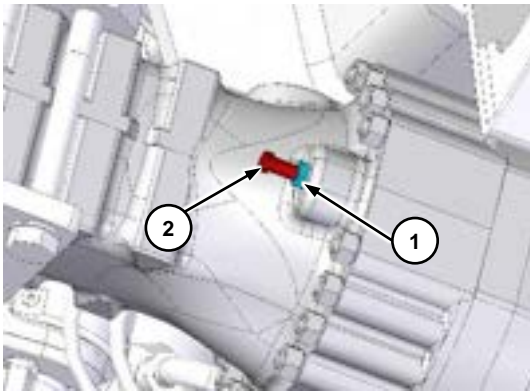

DANGER

Once this operation has been carried out, the vehicle is unbraked.

Be careful!

Manual positioning of the reverse gear in neutral

Following are instructions for mechanically releasing the reverse gear after a hydraulic failure.



WARNING

Before putting the gear into neutral, it is mandatory to place chocks under the vehicle's wheels to prevent accidental movements.

Move under the vehicle near the front axle from the right side of the cardan shaft.

Identify the hydrostatic transmission and hydraulic actuator of the reverse gear ①.

Disconnect the fittings ② and ③ from the actuator and plug the end of the pipes with two suitably sized screw caps.

Move the actuator stem ① with the help of a tool, inserting it into the provided slot, to gain leverage.

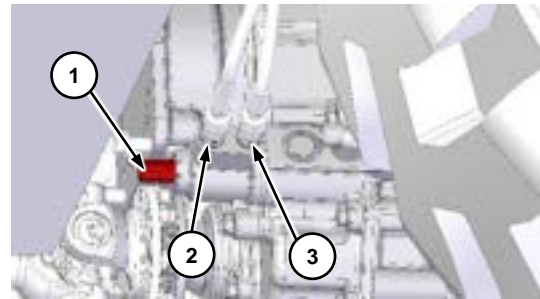

You will hear a click as it moves from fully open to fully closed: this position identifies the Neutral position of the reverse gear.

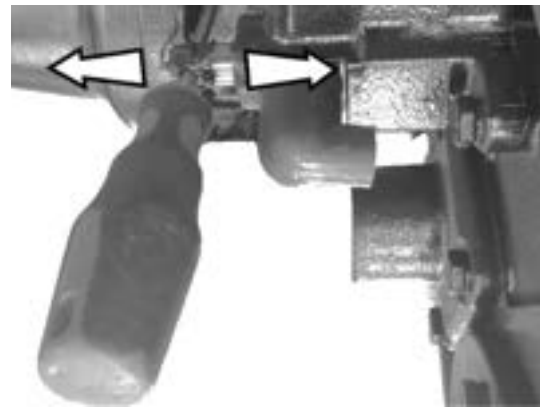

DANGER

Once this operation has been carried out, the transmission is disengaged.

Be careful!

How to tow a vehicle

Secure the vehicle to be towed to the towing vehicle by means of a rigid tow bar suitably dimensioned for the tractive force.

Have an operator seat in the vehicle to be towed to manage the steering by means of hydraulic power steering supplied by the service pump and the I.C. engine running.

If it is impossible to start the engine, operate with the electric emergency pump. Otherwise, operations will be particularly burdensome.

An observer must stand in a safe position to check the outcome of the operations from a distance.

Remove the chocks.

Tow the damaged vehicle as smoothly as possible, avoiding abrupt manoeuvres.

NOTICE

Because of the impossibility of listing all the precautions and towing procedures for all the situations, it is advisable to consult your Dealer for assistance.

MAINTENANCE

General information

Vehicle in maintenance position

Before carrying out any maintenance operations, follow the instructions provided below:

- Park the vehicle on level, non-sagging ground.
- Apply the parking brake.
- Remove connected equipment and heavy loads.
- Lower and retract the telescopic boom.
- If it is necessary to work with the boom raised, secure it with appropriate restraints.
- Switch off the engine and remove the ignition key from the dashboard.
- Disconnect the electrical circuit using the battery disconnection switch.
- Allow all thermal components to cool
- Affix a warning sign saying "Maintenance in progress"

Tightening torques



CAUTION

Unsuitable bolts or those of incorrect size can cause damage, faults and injuries.

Take care to avoid mixing metric nuts and bolts with nuts and bolts in inches.

The tightening torques shown in the following tables are meant as general reference. Exceptions are indicated on a case by case basis.

Before fitting any component, make sure it is as good as new. Bolts and threads must not be worn or damaged. The threads must not have burrs or be chipped.

The components must not be rusty or corroded. Clean the components with a non corrosive detergent. Do not grease the threads of the bolts unless otherwise specified.

Metric nuts and bolts

<i>Diameter</i>	<i>Tightening torque</i>
M6	12 ± 3 Nm
M8	28 ± 7 Nm
M10	55 ± 10 Nm
M12	100 ± 20 Nm
M14	160 ± 30 Nm
M16	240 ± 40 Nm
M20	460 ± 60 Nm
M24	800 ± 100 Nm
M30	1600 ± 200 Nm
M36	2700 ± 300 Nm

Nuts and bolts in inches

<i>Diameter</i>	<i>Tightening torque</i>
1/4	12 ± 3 Nm
5/16	25 ± 6 Nm
3/8	47 ± 9 Nm
7/16	70 ± 15 Nm
1/2	105 ± 20 Nm
9/16	160 ± 30 Nm
5/8	215 ± 40 Nm
3/4	370 ± 50 Nm
7/8	620 ± 80 Nm
1	900 ± 100 Nm
1 1/8	1300 ± 150 Nm
1 1/4	1800 ± 200 Nm
1 3/8	2400 ± 300 Nm
1 1/2	3100 ± 350 Nm

Pipe clamps

For first assembly on a new pipe:

Width	Tightening torque
7.9 mm (0.31 in)	0.9 ± 0.2 Nm
13.5 mm (0.53 in)	4.5 ± 0.5 Nm
15.9 mm (0.62 in)	7.5 ± 0.5 Nm

For a second assembly:

Width	Tightening torque
7.9 mm (0.31 in)	0.7 ± 0.2 Nm
13.5 mm (0.53 in)	3.0 ± 0.5 Nm
15.9 mm (0.62 in)	4.5 ± 0.5 Nm

Tyres

NOTICE

Only use tyres approved by Magni Telescopic Handlers S.r.l.



CAUTION

Use a quick-fit coupling and keep behind the tread when inflating the tyres.

Appropriate equipment and training are necessary to avoid excessive inflation.

Inadequate procedures can cause a tyre to burst or breakage of a rim.

Before inflating a tyre, install it on the vehicle or on a device to hold it steady.

Standard inflation pressures

The inflation pressures given in the Technical Product Information section are those for cold inflation and standard shipment of MAGNI vehicles, and may vary depending on the conditions of use. For more information, contact the tyres supplier.

Do not fill tyres with foam. Tyres filled with foam can damage certain components of the vehicle. Using tyres filled with foam can invalidate the warranty.

Sealing liquid can be inserted into the tyres, if the maximum weight of the vehicle is not exceeded. If the maximum weight of the vehicle is exceeded the warranty and the certification of certain components and structures may be cancelled.

Tyres inflated in the workshop (approx. 18°C (64.4°F) to 21°C (69.8°F)) will be deflated if the vehicle works at temperatures below zero. Adjust the tyre pressure in case of environmental temperatures less than 0°C (32°F).

CAUTION

Periodically check that the inflation value is correct, also according to sensitive climatic variations and/or working environments, as given in this manual, on the sticker applied near each wheel under the mudguard or, if it is missing, contact Magni Telescopic Handlers S.r.l. Support Service.

Inflation with air

Adjust the tyre inflation apparatus regulator to not more than 0.5 bar more than the inflation pressure.

NOTICE

In case of doubt regarding the inflation pressure for fitted tyres, contact your dealer.

Inflation with nitrogen



WARNING

Special equipment and training are necessary for inflating tyres with nitrogen. Non conforming procedures can lead to bursting of a tyre or breakage of a rim, with serious consequences, sometimes even mortal.

The pressure inside a filled nitrogen cylinder is about 150 bar. If not used correctly, the inflation equipment can explode causing serious injuries or even death.

It is advisable to use dry nitrogen for inflating tyres and adjusting pressures. Nitrogen is an inert gas and reduces risk of explosion.

Nitrogen reduces rusting of the wheel, deterioration, and rusting of the rims. Adjust the tyre inflation apparatus regulator to not more than 1.4 bar more than the inflation pressure. Use the same inflation pressure as that with air.

Replacing the wheels

Park the vehicle on a flat surface, apply the parking brake, lower the stabilisers to lift it off the ground and turn the engine off.



CAUTION

Make sure that the surface of the work area is compact and of sufficient consistency to withstand the load placed on it.

If working in an area with loose soil, place plates under the handlers and winch supports to prevent them from sinking.

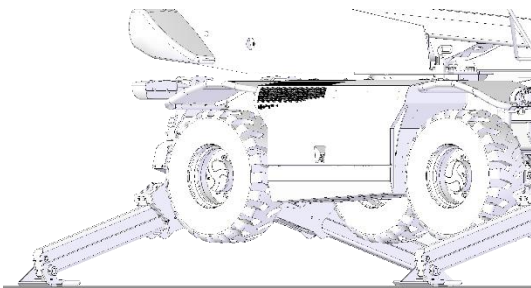

With the vehicle raised, remove the nuts and replace the affected wheel.



WARNING

Pay the utmost attention to movement of the wheel after unfastening the nuts: accidental falling of the wheel can cause serious injuries to the person carrying out this maintenance.

To facilitate handling and replacement, we recommend the use of a slewing variable-reach truck (or one equipped with a wheel clamp) to support the weight of the wheel and prevent it from accidentally falling off the axle.

Refasten the nuts removed earlier and tighten them in a criss-cross pattern using the tightening torque indicated in this manual and marked on the vehicle near the axles.

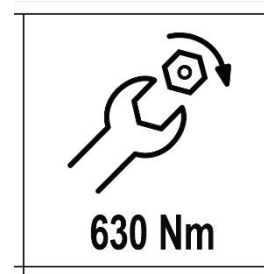

When finished, lower the vehicle to the ground.

Washing



CAUTION

When cleaning the vehicle, avoid the direct use of high pressure water jets on all visible main electrical and hydraulic elements. (E.g. under the cab, on the telescopic boom head, inside the rear cab compartment, on the back of the vehicle, on the valve transducers and on all microswitches in general, etc.).



Liquids, lubricants and spare parts

List of liquids and lubricants recommended for routine maintenance

Compartment	Type	Strength	Operating temperature (min/max)	Quantity
Cooling circuit	KEMETYL Carix Premium Longlife	50%/50%*	-41°C -42°F	38 l
		35%/65%*	-22°C -7,6°F	10 U.S. gal
Fuel tank	Diesel	-	-	175 l ^a / 240 l ^b /
AdBlue tank	ISO 22241-1 (AdBlue)	-	-	10 l 2,64 U.S. gal
Engine sump	DQC III LA DQC IV LA	SAE 5W30	-27°C/+30°C -16,6°F/86°F	9 l 2,4 U.S. gal
		SAE 5W40	-30°C/+40°C -22°F/104°F	
		SAE 10W30	-20°C/+30°C -4°F/86°F	
		SAE 10W40	-20°C/+40°C -4°F/104°F	
		SAE 15W30	-15°C/+35°C 5°F/95°F	
		SAE 15W40	-15°C/+40°C 5°F/104°F	
Front axle gear	Oil	SAE 85W90	-27°C/+77°C -4°F/170,6°F	2.8 l 0,78 U.S. gal
Front/rear axles differentials	Oil	SAE 85W90	-27°C/+77°C -4°F/170,6°F	11 l 2.9 U.S. gal
Wheel reduction gears	Oil	SAE 85W90	-27°C/+77°C -4°F/170,6°F	1.6 l 0,42 U.S. gal
Slewing ring rotation reduction gear <i>Reggiana Riduttori</i>	Oil	ISO VG 150		2 l ^c 0,53 U.S. gal ^c
Slewing ring rotation reduction gear <i>Liebherr</i>	Oil (reduction gear)	SAE 85W90 API GL5	-20°C/+90°C -4°F/194°F	3 l ^c 0,8 U.S. gal
	Oil (brake)	ATF-Oil		0,2 l ^c 0,05 U.S. gal
Hydraulic fluid tank	Oil	ISO 46	-15°C/+130°C 5°F/266°F	107 l 28,3 U.S. gal
Greasing points	Grease	NGLI 2	-30°C/+120°C -22°F/248°F	as requ.
Boom sliding	Grease (KERNITE Delavan)	PTFE NLGI 2	-20°C/+150°C -4°F/302°F	as requ.

* The percentages correspond, in the order, to the composition of the antifreeze+distilled water mixture:

- 50%/50% means a mixture in equal parts;
- 35%/65% corresponds to a mixture of 35% antifreeze and 65% distilled water.

^a Value for vehicle models RTH 5.18, 5.21, 5.23, 5.25.

^b Value for vehicle models RTH 6.22, 6.26.

^c Not present in models: RTH 5.18.

List of spare parts for routine maintenance

<i>Type of spare part</i>	Description	Quantity	Magni Code	
			Stage IIIA	Stage V
<i>External cab air filter</i>	Filter cartridge	1		09371
<i>Internal cab air filter</i>	Filter cartridge	1		88120
<i>Engine air filter</i>	Primary filter cartridge	1		24069
<i>Engine air filter</i>	Safety filter cartridge	1		12684
<i>Hydraulic fluid tank bleed</i>	Bleed cap	1		39642
<i>Alternator transmission belt</i>	Belt	1		34631
<i>Compressor transmission belt</i>	Belt	1		24230*
<i>Fuel filter</i>	Filter cartridge	1		24309
<i>Fuel pre-filter</i>	Filter cartridge	1		24293
<i>Engine oil filter</i>	Filter cartridge	1		24289
<i>AdBlue pump filter</i>	Filter cartridge	1	/	33204**
<i>AdBlue tank filter</i>	Filter cartridge	1	/	99018**
<i>Hydraulic transmission fluid filter (delivery/suction)</i>	Filter cartridge	1		23094

* Only for models with air conditioning kit installed.

** Only for Stage V engines equipped with SCR catalytic converter.

NOTE: Always check the codes of listed spare parts with your Magni Telescopic Handlers dealer.

Maintenance Schedule



CAUTION

Read and understand all the warnings and instructions before starting any maintenance operation.

Before carrying out any maintenance operation, make sure all the scheduled actions have been carried out as planned.

In cases where the vehicle operates in particularly harsh environmental conditions (e.g.: quarries, desert areas, dusty and / or sandy areas) plan to halve the maintenance intervals indicated below.

As required

Transmission belt - replacement
 AdBlue® filter
 Fuel tank - refuelling
 Windscreen washer liquid tank – filling

Every 10 hours of operation or daily

Engine oil - check
 Coolant - check
 Telescopic boom sliding blocks – check
 Liquid leaks – check
 Emergency hydraulic pump - operation test
 Wheels - check the tyre pressure

Every 50 hours of operation or every 2 weeks

Transmission shaft –
 lubrication of universal joints
 Hydraulic fluid – check
 Telescopic boom sliding blocks – lubrication
 Telescopic boom pins – lubrication
 Fuel prefilter – discharge water
 Wheels – check tightness of nuts

Every 250 hours of operation or every 3 months

Transmission belt - check
 Differentials oil - check
 Two-speed reduction gear oil – check
 Wheel reduction gear oil – check
 Steering elements – lubrication

Every 500 hours of operation or every 6 months

Hydraulic fluid filter – replacement (suction)
 Hydraulic fluid filter – replacement (drainage)
 Engine oil and filter – replacement
 Engine radiator – cleaning
 Engine pipes - inspection
 Control - rotation slewing ring gear

Every 1000 hours of operation or every year

Fuel filter – replacement
 AdBlue® filter – replacement
 Air filter – replacement of primary cartridge
 Fuel prefilter – replacement
 Differentials oil - change
 Two-speed reduction gear oil – change
 Wheel reduction gears oil – change
 Telescopic boom sliding blocks – adjust the play
 Fuel tank – clean

Every 1500 hours of operation

Fuel filter – clean mesh element
 Fuel prefilter – replacement

Every 2000 hours of operation or every 2 years

Hydraulic fluid – change
 Air filter – replacement of safety cartridge
 Coolant - change

Maintenance operations

Safety information

Before carrying out any maintenance, please read the Safety and Warnings section in this manual in detail.

A summary of the symbols used with a brief description is given again:



GENERIC DANGER



DANGER OF BURNS



DANGER OF CRUSHING



DANGER FROM HANGING LOAD



ELECTRICITY



RISK OF INTOXICATION



BATTERIES



FLAMMABLE MATERIAL



PRESSURISED FLUIDS



MOVING PARTS



RISK OF SLIPPING



RISK OF FALLING, TRIPPING



NO SMOKING OR LIGHTING UP ANY KIND OF NAKED FLAME

All maintenance must be carried out by personnel who have been instructed, trained and have the necessary technical skills to work safely.

Battery disconnect switch

Before starting any maintenance work, switch off the engine and disconnect the power supply by turning the battery disconnect switch in the engine compartment.

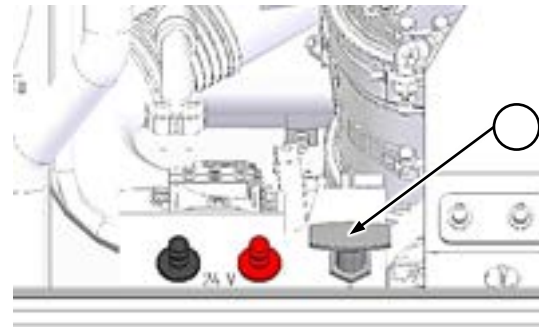

DANGER

Maintenance carried out by untrained operators without the appropriate technical skills can lead to serious health risks and even death.

Maintenance operations under the telescopic boom

The vehicle is equipped with a mechanical safety device (yellow) to be affixed to the lifting cylinder rod that prevents it from closing if maintenance needs to be carried out underneath the telescopic boom.

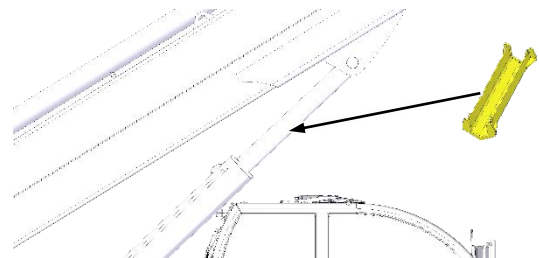

It is also possible to fix the telescopic boom to the overhead crane by means of the 4 eyebolts on its structure.

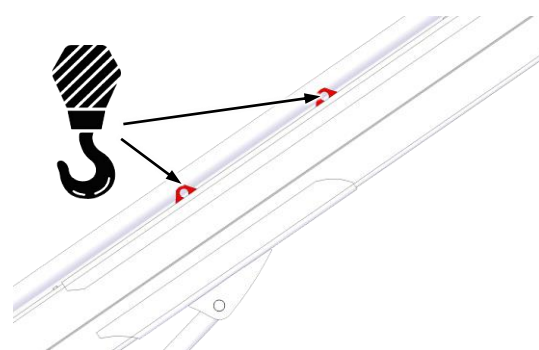

Maintenance operations in areas not accessible from the ground

For maintenance on areas/parts of the vehicle that are not accessible from the ground, it is recommended not to climb on it but to use alternative systems such as ladders with platforms (EN 131-7)



DANGER

The maintenance item carried out on areas/parts of the vehicle that are not accessible from the ground without the use of appropriate safety devices and equipment can lead to serious health risks and even death.

Hydraulic hoses

Inspection

Check the condition of the hydraulic hoses on the vehicle for a visual inspection and ensure that there are no leaks from the connectors 1, fittings 2 or along the hose 3.

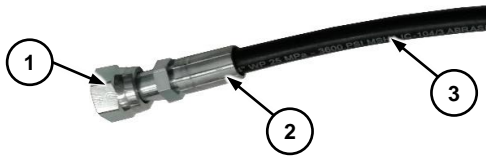

If a fault is found in any of the points indicated above, replace the hose and check the condition of the seals on the part the hose screws onto (connector, valve, hose).

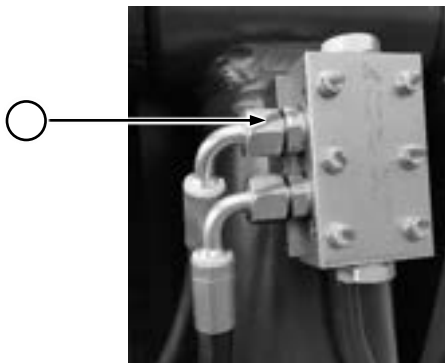

Differentials oil

Maintenance for the axle differentials (front and rear) is as follows.

Check every 500 hours

Set the vehicle on a flat surface in the parking position. Make sure no one approaches the work area.

Go to the front axle.

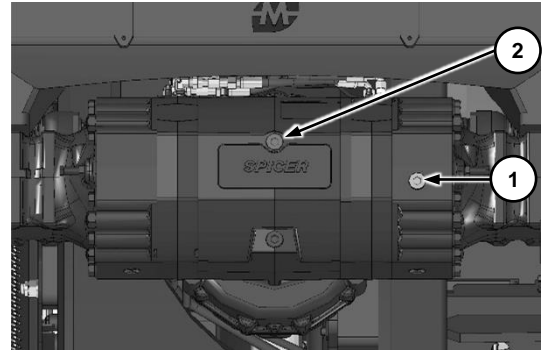

Remove the level plug ①. The oil must flow out through the opening.

If necessary, remove the filler cap ②. Add oil to the correct level. Close level cap ①, and then filler cap ②. Clean the axle surfaces.

Replacement every 1000 hours

Set the vehicle on a flat surface in the parking position. Make sure no one approaches the work area.

Place suitably sized containers under the front axle.

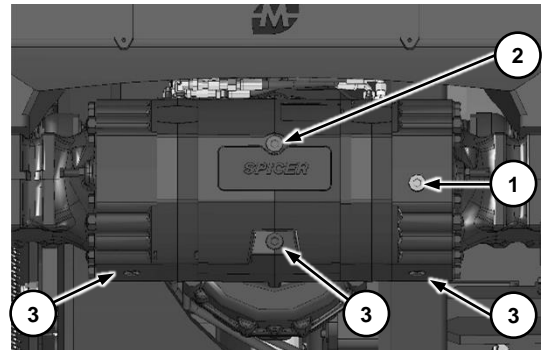

Remove the three drainage caps of the differential ③. Wait for the oil to drain completely out of the differential. To speed up the operation, remove filler cap ②.



WARNING

Do not dispose of used oil in the environment, but take it to the appropriate storage and disposal sites.

Refit caps ③ and tighten adequately. Remove the level plug ①.

Pour fresh oil of the correct type (refer to the Liquids and Lubricants table in this manual) through hole ②. Fill in stages and check the flow of oil through level hole ①.

When the correct level is reached, refit level cap ① and filler cap ②. Repeat the above operations for the rear axle too, shown below.

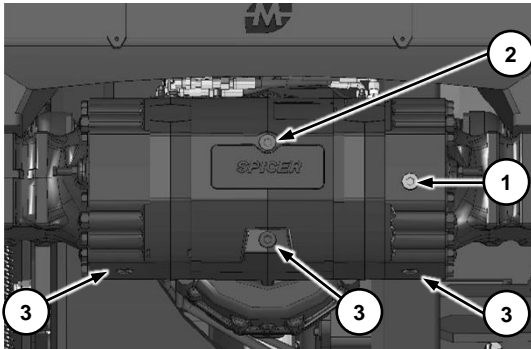

Wheel reduction gears oil

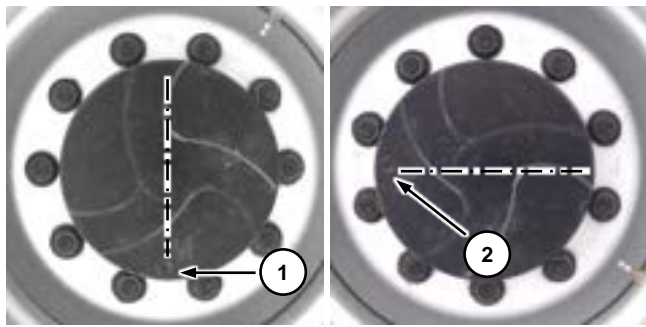

Check every 250 hours

Set the vehicle on a flat surface in the parking position. Turn the reduction gear cap in the horizontal position ②. Remove the cap. The oil level is correct when the oil flows out through the filler hole. If necessary, top up with oil to the correct level. Refit the cap. Repeat this operation for each wheel.

Replacement every 1000 hours

Set the vehicle on a flat surface in the parking position. Place a suitably sized container under the reduction gear. Turn the reduction gear cap in position ①. Remove the cap and wait for the oil to drain out completely.

Turn the reduction gear cap in position ②. Fill oil through the hole to the correct level. Refit the cap. Repeat this operation for each wheel.



WARNING

Do not dispose of used oil in the environment but take it to the appropriate storage and disposal sites.

Transmission shaft

Lubrication of universal joints

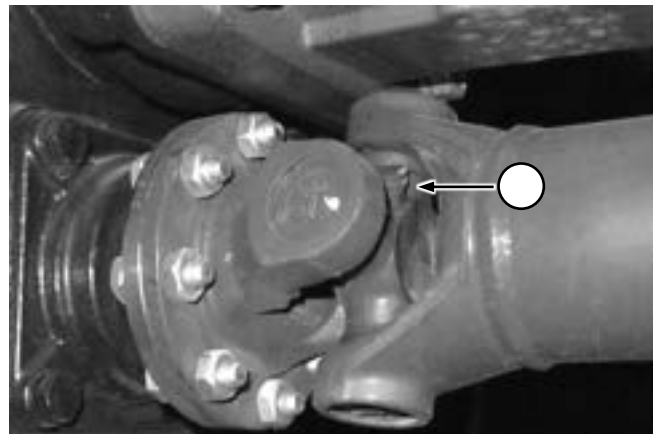

Set the vehicle on a flat surface in the parking position. Make sure no one approaches the work area. Lubricate the universal joints by injecting grease into the grease nipples. Repeat for all the transmission shaft joints. Remove the excess grease.

Steering elements

Lubrication

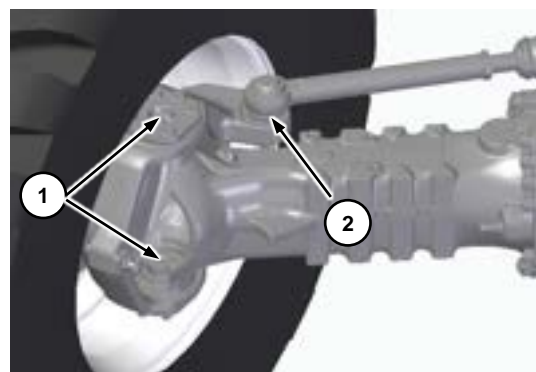

Lubricate the wheels rotation pins ① by injecting grease in the grease nipples provided for the purpose. Remove the excess grease. Lubricate the ball joint ② injecting grease in the grease nipples provided for the purpose. Remove the excess grease.

Repeat the operations for each wheel.

Axles

Lubrication of oscillation bushes



Set the vehicle in the parking position. Make sure no one approaches the work area. Stand near the front axle oscillation bushes. Inject grease in the grease nipples present on both sides of the axle (front and rear).

Repeat the lubrication for the rear axle.

Transmission belt



CAUTION

Work on the transmission belt only with the engine stopped! After repairs, make sure all the protection devices have been refitted and that no tool has been forgotten on the engine.

Checking the belt tension

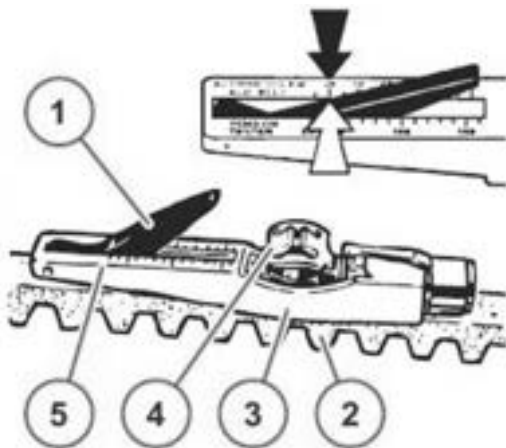

To check the tension of the belts, lower the boom of indicator ① in the tester.

Place the guide ③ between two pulleys on the V-belt ②. At this point, the stop must be on the side.

Press button ④ in the right corner with respect to V-belt ② uniformly until the spring clicks audibly.

Lift the tester gently, without modifying the position of the indicator arm ①.

Read the value measured on the intersection point (arrow), scale ⑤ and indicator arm ①.

Correct the tension if necessary and repeat the measurement.

The belt tension tester can be ordered through the Customer Service.

Replacement

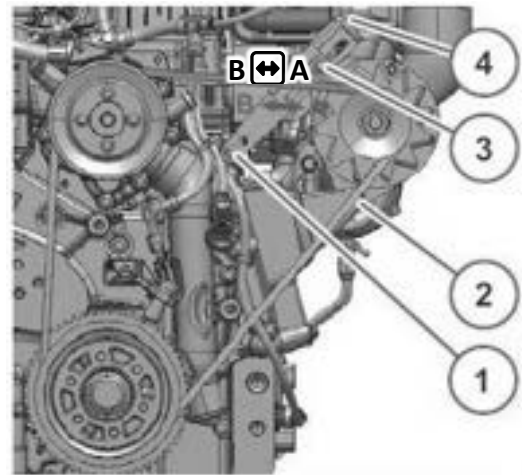

① screw - ② screw - ③ screw - ④ adjuster wrench.

To replace the transmission belt: unscrew the screw and lock nut, move the generator above the adjuster wrench in direction (B) until the belt slackens, remove the belts and fit the new ones, reposition the generator above the adjuster wrench in direction (A) until the belt tension is correct, check the belt tension:

- pre-tensioning 650 ± 50 Nm
- correct tension 400 ± 50 Nm

tighten the screw and lock nut.

Tightening torque:	screw (1)	30 Nm
	screw (2)	42 Nm
	screw (3)	30 Nm

Engine oil



WARNING

Do not operate with the engine running!

Do not smoke or use naked flames!

Danger of burns!



Replace every 500 hours.

During operations on the lubricant oil system, ensure utmost cleanliness. Thoroughly clean the area around the components involved from time to time.

Dry the damp parts with air jets. For handling lubricant oils follow the safety directives and specific local standards.

Dispose of the leaked lubricant oil and the filter elements. Do not let the used lubricant oil spread in the ground. Run a test cycle after every intervention.

At the same time, ensure sealing and pressure of the lubricant oil and then check its level.

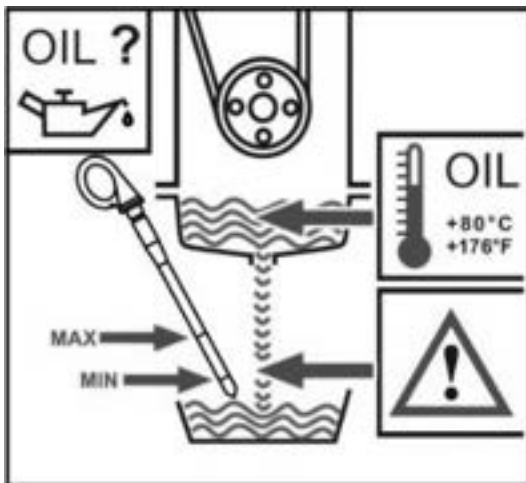

An insufficient and/or excessive lubricant oil level can damage the engine. Check the oil level only with the engine horizontal and stopped. Check the lubricant oil level only while it is warm, 5 minutes after the engine is switched off. Do not remove the oil level rod with the engine running. Danger of burns.

Checking the engine oil level

Remove the rod and wipe it clean with a cloth, do not leave fibres.

Insert the oil rod up to the stop then remove it and read the lubricant oil level.

The level must always be between the MIN and MAX notches. Top up to the MAX notch if necessary.

Changing the engine oil

Replace every 500 hours or at the same time as changing the engine oil.

Heat the engine until the oil temperature reaches $> 80^{\circ}\text{C}$ (176°F).

Park the vehicle on a horizontal surface and stop the engine.

Place a container under the drain screw, unscrew the latter and drain out the lubricant oil.



WARNING

Do not dispose of used oil in the environment, but take it to the appropriate storage and disposal sites.

After draining, reposition the screw with a new sealing ring and tighten by applying a 55 Nm torque.

Fill lubricant oil, warm the engine to a temperature $> 80^{\circ}\text{C}$ (176°F) and check the lubricant oil level.

Top up, if necessary.

Replacing the lubrication oil cartridge



Loosen the filter using the tool and unscrew it.

Collect the lubricant oil that flows out.

Wipe the surface of the filter-holder with a clean cloth that does not leave lint.

Oil the original DEUTZ filter cartridge seal slightly.

Manually screw the new filter tightening it by applying a 10-12 Nm torque.

Fuel prefilter



WARNING



FLAMMABLE MATERIAL

Fuel is flammable and can cause severe burns and death.

Do not smoke or use naked flames while working on the fuel line.

Clean the engine parts and engine compartment to remove all traces of fuel to prevent risk of fire.

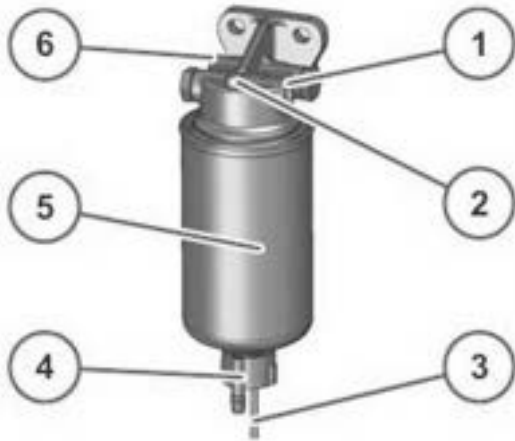

① pump fuel supply - ② bleed screw - ③ electric connection for the water level sensor - ④ drainage cap - ⑤ filter cartridge - ⑥ fuel tank inlet

Replace every 1000 hours

Emptying the water container

Stop the engine.

Place a suitable container.

Electrical connection.

Disconnect the cables.

Loosen the drainage screw.

Drain the liquid until the pure diesel fuel starts flowing out.

Fit the drainage cap by applying a tightening torque of 1.6 ± 0.3 Nm.

Connect the cables.

Replacing the fuel filter cartridge

Stop the engine.

Block the fuel intake to the engine (if the tank is positioned at the top).

Place a suitable container.

Electrical connection.

Disconnect the cables.

Unscrew the drainage cap and drain out the liquid.

Remove the filter element.

Wipe the surface of the new filter cartridge and the opposite side of the filter head to remove dirt.

Slightly dampen the surfaces of the filter cartridge with fuel and re-screw the filter head clockwise (17-18 Nm).

Fit the drainage cap by applying a tightening torque of 1.6 ± 0.3 Nm.

Connect the cables.

Open the fuel cock and bleed the system (see "Bleeding the fuel system").

Fuel filter

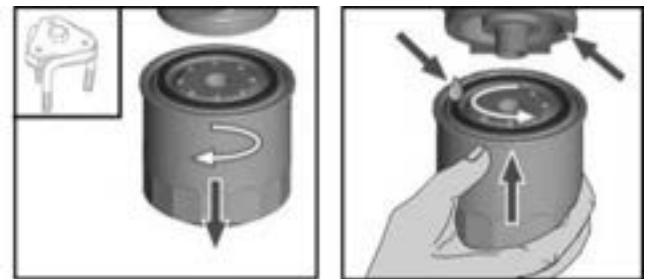
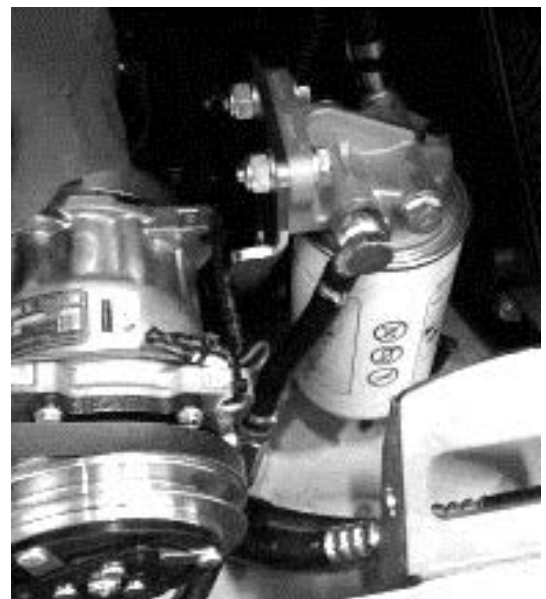

Replace every 1000 hours

Loosen the filter using the tool and unscrew it.

Collect the fuel that flows out.

Wipe the surface of the filter-holder with a clean cloth that does not leave lint.

Oil the original DEUTZ filter cartridge seal slightly.

Manually screw the new filter tight.

Tighten the clamps of the anti-twisting safety (optional).

Bleed the fuel supply system.

Bleed the fuel supply system

The fuel supply system is bled by means of the fuel delivery electric pump.

To make sure fault messages are not generated, try not to start up during the bleeding process.

This process is carried out as follows.

Switched on.

The fuel delivery electronic pump is activated for 20 seconds to bleed the fuel supply system and generate the necessary fuel pressure. Wait for the fuel delivery electric pump to be deactivated from the control unit.

Switched off.

Repeat the process at least twice until the fuel supply system bleeding is complete.

AdBlue® filter



RISK OF INTOXICATION

The ammonia in AdBlue® is highly toxic and corrosive, and in contact with tissues can cause serious burns or even death.

Wear protective clothing and goggles to avoid contact with the tissues. In case of contact with tissues, rinse thoroughly with plenty of water and get medical care.

Before working on the AdBlue® supply system, read the safety information given in the section "information regarding AdBlue®".

Replacement

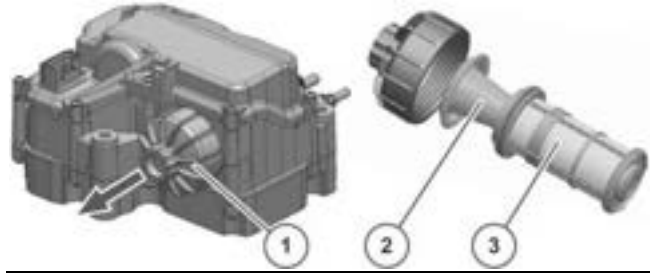

① cover, ② compensator, ③ filter cartridge.

Replace every 1000 hours

Proceed with replacement of the filter cartridge of the AdBlue® supply pump by following the indications given:

- switch the engine off,
- disconnect the electric terminals,
- place a suitably sized container under the pump and filter to hold the liquid flowing out,
- remove the cover using a 27 mm (1.06 in) hex head wrench,
- remove the compensator and filter element completely,
- replace the filter element and refit it together with the compensator,
- fit the cover by applying a 22 ± 2.5 Nm tightening torque,
- reconnect the electrical system,
- start the engine.

NOTICE

For drive units satisfying the Stage V anti-pollution standards, in order to protect the AdBlue® purification system, wait at least 5 minutes after the I.C. engine is switched off, before acting on the main electric circuit to disconnect it.

Fuel tank

Refuelling

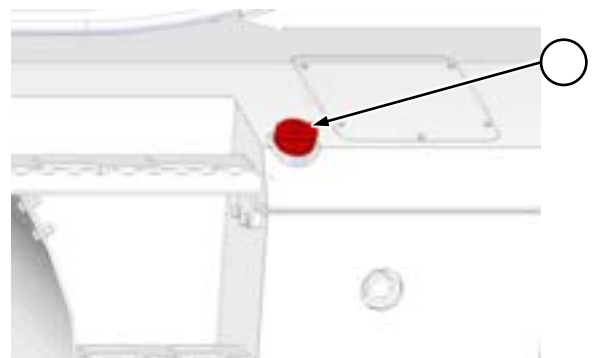

Set the vehicle in the parking position. Switch the engine off.

Unlock the fuel filler cap located on the left side of the vehicle slewing variable-reach truck, using the appropriate key. Unscrew the tank cap by turning it anticlockwise.

Refuel using suitable fuel. Screw the fuel cap in and lock using a wrench.



CAUTION

For drive units complying to Stage V regulatory standards use only fuels with low sulphur content, as indicated on the label positioned on the side of the tank filler opening.



Cleaning

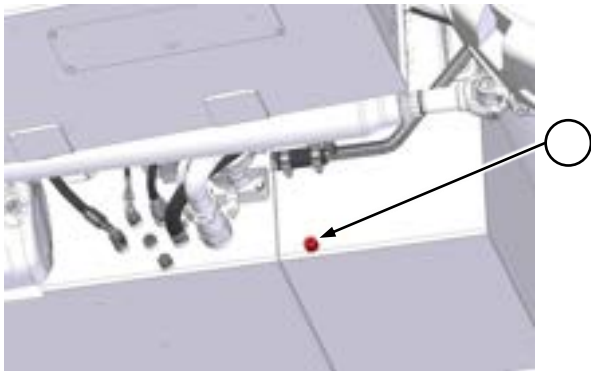

To facilitate the operation, place the vehicle in park position, stabilise it and switch it off.

Place a suitable sized container under the fuel tank near drainage cap, then remove the filler cap

Unscrew the drainage cap and drain out the tank completely.

Pour 10 litres of clean fuel into the tank to rinse out impurities that may be present at the bottom by draining it out.

Close and tighten the drainage cap. Fill the tank with clean fuel. Check to make sure there are no leaks.

Coolant



WARNING

The coolant is pressurised and at high temperature with the engine switched on. When the cap is removed, the liquid may flow out violently and cause serious burns.

Make sure the engine is cold before working on the cooling system

Inspection

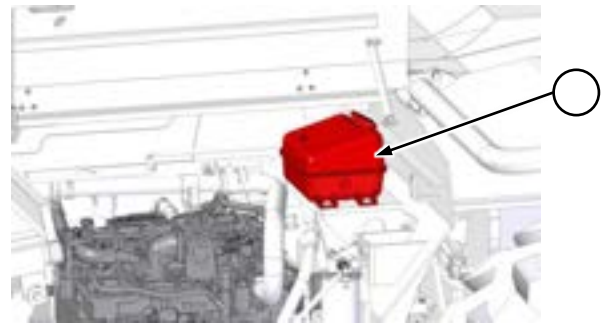

Set the vehicle in the parking position.

Check the level in the expansion tank placed inside the engine compartment. The level is correct when it is half-way on the inspection window.

Open the tank, check the coolant additive concentration ratio using the instrument concerned (e.g. hydrometer, refractometer)

If necessary, top up with a suitable mixture depending on the use.

Refit the cap and make sure it is tightened properly. Run the engine to bring it to the required temperature. Switch off the engine and check for leaks in the circuit.

Bleeding the cooling system

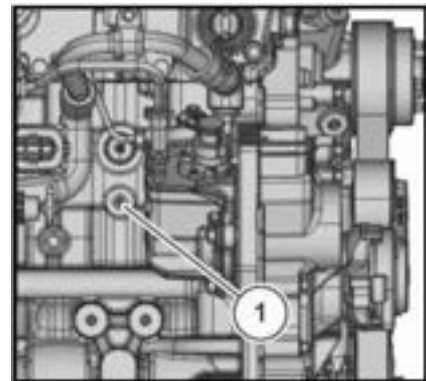

Replace coolant every 2 years to eliminate possible corrosion of cooling elements.

Set the vehicle in the parking position.

Remove the radiator cap carefully to release the residual pressure.

Place a suitably sized container under the drainage cap to collect the coolant flowing out.

Remove screw **1** and drain out the coolant. If the screw is not accessible, drain through the engine oil radiator (coolant duct).

Refit the screw by applying mastic.

Refit the radiator cap.

Engine radiator

Cleaning

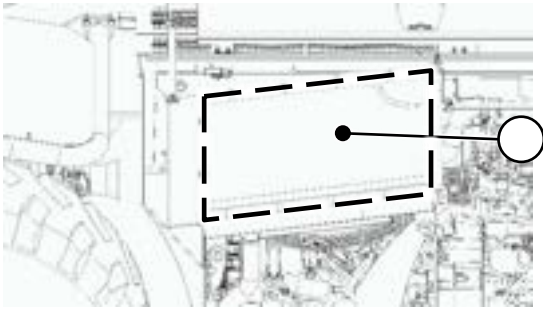

To remove dust and debris from the radiator mass, compressed air, pressurised water or steam can be used. However, it is preferable to use compressed air.

NOTICE

When using pressurised water, keep the high pressure jet cleaning nozzles at a distance of at least 50 cm from the radiator mass. Bringing the nozzle too close to the radiator mass can lead to risk of damaging the radiator.

Hydraulic fluid

Inspection

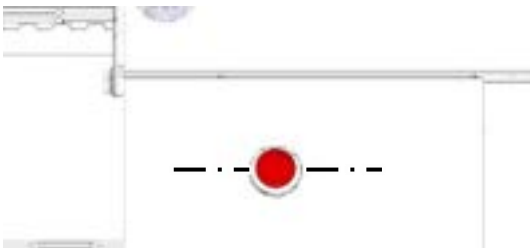

The hydraulic fluid tank is on the left side of the vehicle. Check the hydraulic fluid level through the inspection window present on the tank.

The oil level is correct if it is halfway on the window, as shown by the dashes in the figure.

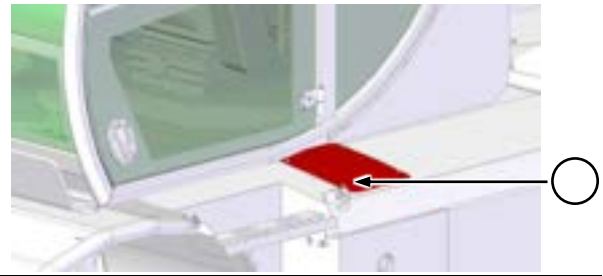

If necessary, add oil by accessing the cap located under the tank cover. Pour oil of suitable strength up to the correct level. Refit the cap and tighten it manually.

Replacement

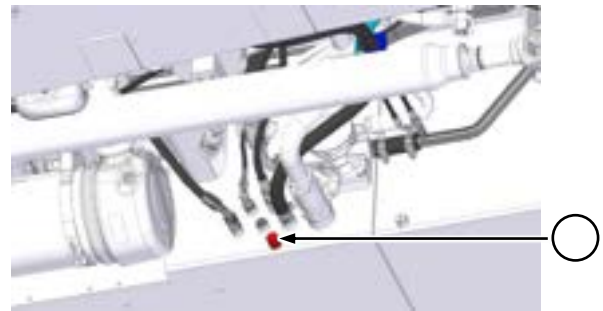

Go under the vehicle to access the tanks drainage caps.

Place a suitably sized container under the bleed valve **1**. Unscrew the cap and drain out the oil. To speed up the operation, also unscrew the filler cap.

Refit drainage cap **1**, and fill the tank with fresh fluid. Close the filler cap.

Start the engine. Check to make sure there is space to extend the telescopic boom completely. Raise and lower the boom a number of times. Extend and retract the boom a number of times.

With the boom in the transport position, drive the vehicle carefully forwards. Steer the vehicle to the right and left.

Park the vehicle and check the oil level. Add oil if necessary.

Hydraulic fluid filter



CAUTION

The vehicles use a single filter for hydraulic fluid: the filter placed on the inside of the hydraulic tank has the combined function for oil at the suction as well as return.

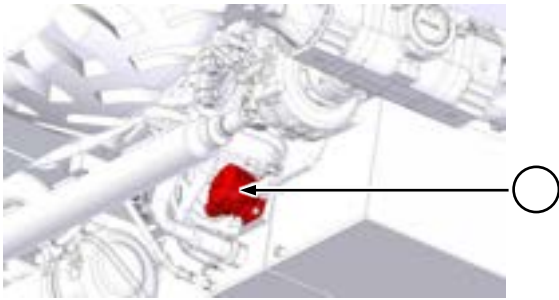

Stabilise the vehicle to facilitate accessibility to the filter in question: clean the filter housing and surrounding areas to prevent dirt from entering the circuit. Unscrew the cap.

Replacement of the filter cartridge does not necessarily involve drainage of the tank: the filter housing has a special closure system. When it is being removed, the oil present inside the filter normally flows out.

Remove the filter cartridge and dispose of according to the regulatory standards in force. Insert a new filter cartridge of the same type.

Refit the filter cover. Start up the engine and check for leaks.

Check for a drop in the oil level through the window present on the tank: if required, top up with the quantity necessary to reach the correct level.

Two-speed reduction gear oil

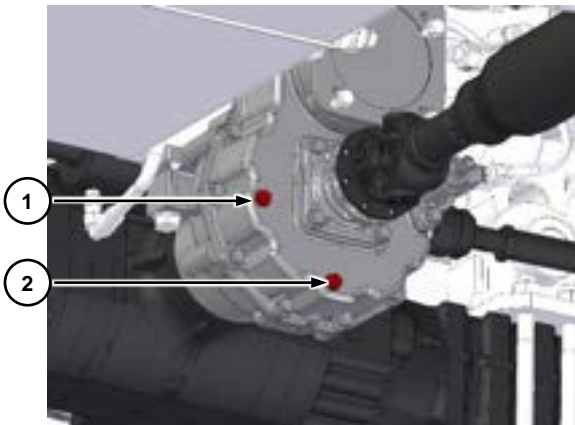

Inspection

Set the vehicle in the parking position. Make sure no one approaches the work area.

Remove the cap ①. Check the oil level: the level is correct if it reaches the base of the hole. Add oil if necessary.

Refit and tighten cap ①.

Replacement

Place a suitably sized container under the two-speed reduction gear.

Remove the cap ①. Remove the magnetic drainage cap ②. Wait for the oil to drain out completely.

Clean the magnetic cap ② to remove iron filings, then refit and tighten it.

Fill the reduction gear with oil through hole ① up to the prescribed level. Refit and tighten cap ①.

Engine air filter

The efficiency and life of the engine depend greatly on the quality of air taken in. A dirty or damaged air filter can seriously affect the correct working of the engine and increase the possibility of a failure.

Replace the air filters strictly according to the schedule indicated in this Manual. Do not try to wash dirty filters.

If the vehicle is expected to be used in environments with a lot of dust or high concentrations of contaminating or polluting agents in the air, halve the time interval between one filter replacement and the next.

Replacing the primary cartridge

Set the vehicle in the parking position. Rotate the turret to the left through 45° to allow easier access to the filter housing.

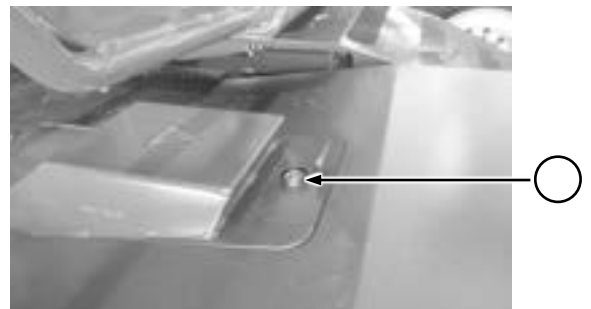

Lift the protective cover on the locking mechanism and then use the key to open the trap-door and lift it to access the filter compartment.

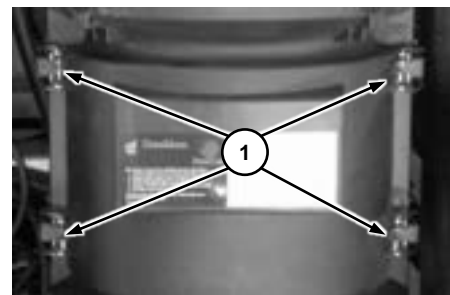

Unhook the four fastenings **1** and remove the filter housing cover.

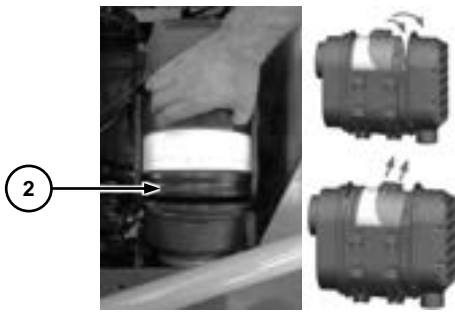

Grip the filter housing and remove it from its seat. Lift the filter element out of the filter housing.

Wipe thoroughly inside the filter housing with a damp cloth. Avoid the use of aggressive solvents or products as these can damage the safety filter or the filter housing.

Install a new filter element. Make sure the filter element is inserted properly in its seat. If installation is difficult, grease the rubber gasket **2** slightly with silicone grease.

Replacing the safety cartridge

Carry out the primary filter removal procedure described earlier.

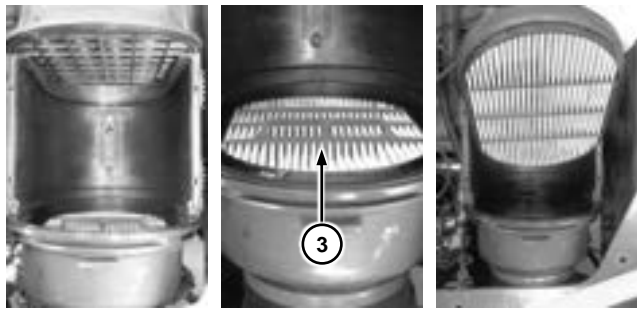

Grip the filter element by means of handle **3** and pull to separate it from its seat. Remember the direction of assembly.

Install a new filter element. Lightly grease the outer gasket of the new filter element with silicone grease.

Cab air filter

Replacement

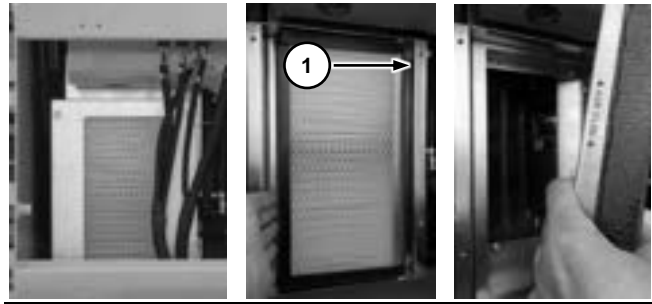

Open the compartment in the rear part of the cab to access the filter housing.

Unscrew the four screws **1** and remove the filter holder frame.

Remove the air filter and replace it with a new one of the same type.

For reassembly repeat the above operations in reverse order. Check the correct direction of assembly before fitting the holder frame.

Telescopic boom sliding blocks

Inspection

Set the vehicle in the parking position. Extend the telescopic boom completely.

Check to make sure the boom movement is smooth. Ensure that there are no abnormal vibrations, unusual noises, and no part of the boom gets heated due to friction during the movement.

Check for the presence of a sufficient layer of grease on the sliding surfaces and on the sliding blocks.

Lubrication

Position the vehicle on a flat surface in a large enough area. Put the telescopic boom in the horizontal position and extend it fully.

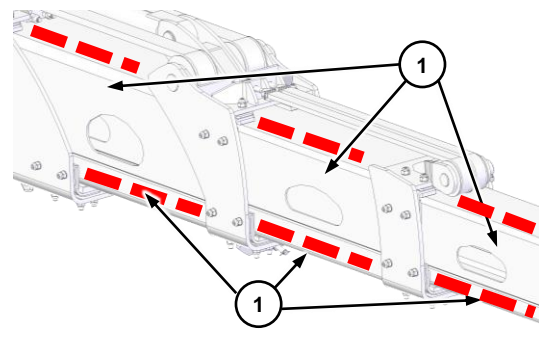

Thoroughly clean all the sliding surfaces **1** in contact with the sliding blocks.

Using a brush or roller, apply a thin layer of grease on the sliding surfaces of the sliding blocks ① on all four sides of the extensions. Repeat this operation for each extension.

Retract and extend the telescopic boom a number of times to distribute the grease uniformly.

Remove excess grease to prevent accumulation of dirt.

Adjusting the play

Position the vehicle on a flat surface in a large enough area. Remove any equipment from the quick-fit coupling and move the telescopic boom into the horizontal position. Retract the telescopic boom almost completely.

Move to the front of the boom and identify the sliding blocks as shown below.

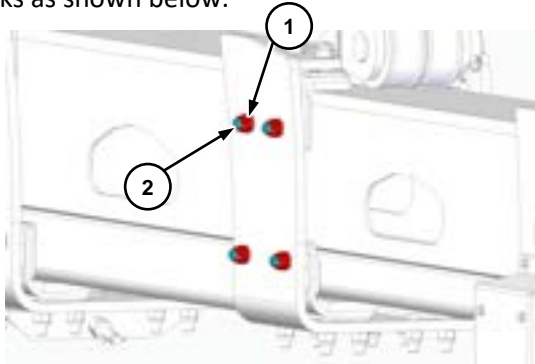

Loosen the lock nuts ① of the upper and side sliding blocks at the top of the boom. Screw all the grub screws ② all the way without tightening them, then unscrew them all by half a turn.

Repeat the adjustment operation for the lower and side sliding blocks at the bottom of the boom.

Tighten each lock nut holding the relative screw firm. Tightening torque: **100 Nm**.

Try to adjust the sliding blocks in such a way that all the screws ② protrude to the same extent.

Always try to adjust the sliding blocks symmetrically, to facilitate boom extension centring.

After completing the operations try to extend and retract the boom to check the boom movement is smooth.

If the movement of the boom is not smooth, repeat the adjustments, unscrewing the screws ② by one complete turn instead of by half a turn.

Contact your dealer for any clarification or for assistance if the sliding blocks are worn and need to be replaced.

Telescopic boom pins

Lubricate the pins of the movable parts of the telescopic boom at regular intervals. Lack of lubrication can cause seizure of the pins in their seats.

Wipe excess grease to prevent accumulation of dirt.

Lubrication of boom pin

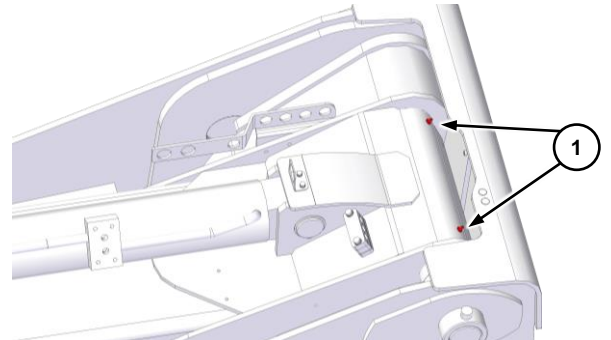

Lubricate pin ① injecting grease in both grease nipples present on the boom.

Lubrication of lift cylinder pins

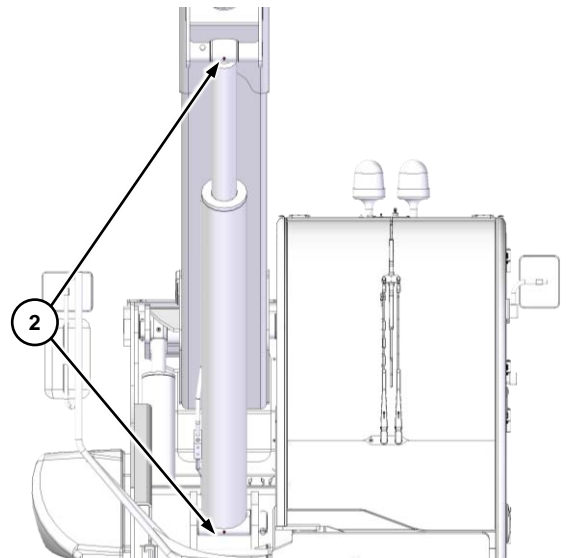

Lubricate pins ② of the lift cylinder. To make access to the grease nipples easier, lift the telescopic boom completely.

Lubrication of compensation cylinder pins

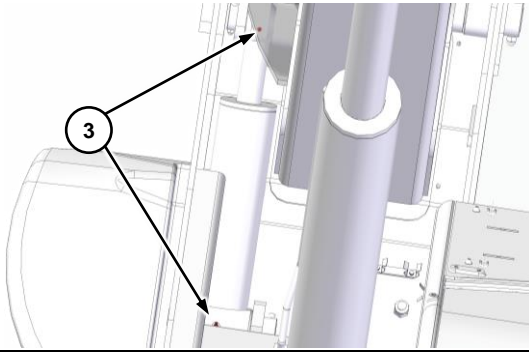

Lubricate pins ③ of the compensation cylinder. To make access to the grease nipples easier, lift the telescopic boom completely.

Lubrication of quick-fit coupling pin

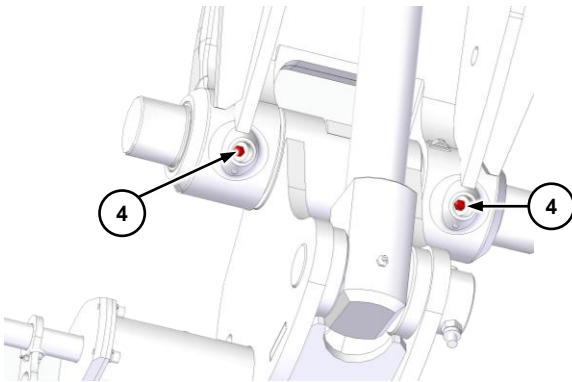

Lubricate the pin of quick-fit coupling ④ through the grease nipples.

Lubrication of slewing cylinder pins

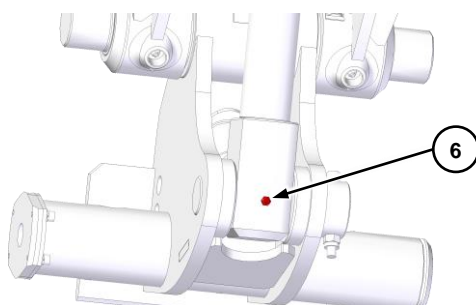
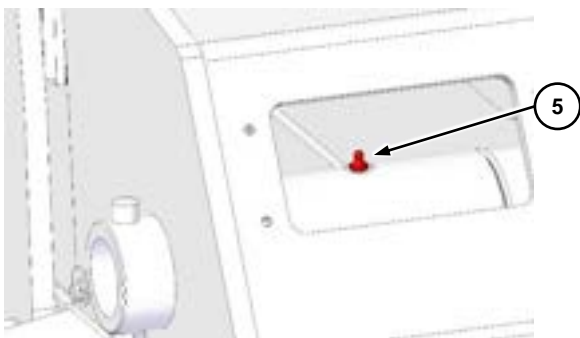

Lubricate pivots ⑤ and ⑥ of the swing cylinder using the grease nipples on the top and base of the swing cylinder: for the top grease nipple, remove the cover at the top of the last extension at the top of the telescopic boom.

Telescopic boom chains

Checking and lubrication

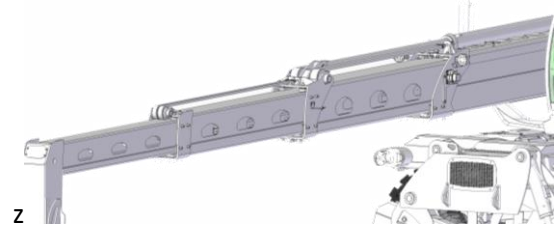

Position the vehicle on stabilisers. Centre the turret and extend the telescopic boom completely in the horizontal position.

Clean the chains and inspect carefully for signs of wear. Brush thoroughly to remove impurities. For maximum efficiency use a hard nylon brush and clean fuel.

Blow on the chains with compressed air. Lubricate with a brush soaked in oil. Wipe excess oil using a clean cloth.

Lubricate the pins of the rotation pulleys by injecting grease in the grease nipples provided for the purpose.

Repeat the operations for all the outer chains and for all the pulleys of each extension of the telescopic boom.

Adjustment

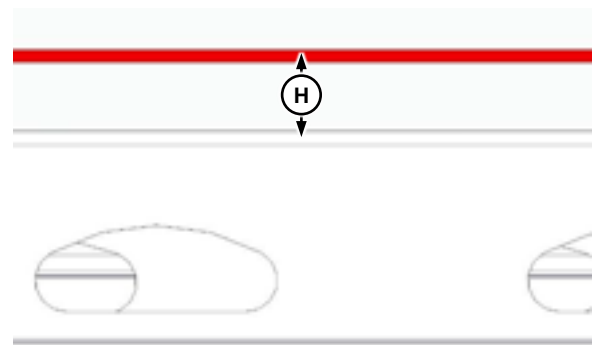

The services of an operator and an inspector are required to check the chains to see if they require adjustment.

Extend the telescopic boom in the horizontal position. Provide a rapid pulse to retract the boom and observe the oscillation of the chains. If, during oscillation, distance H from the upper surfaces of the extensions is less than 4 cm, the chain must be adjusted.

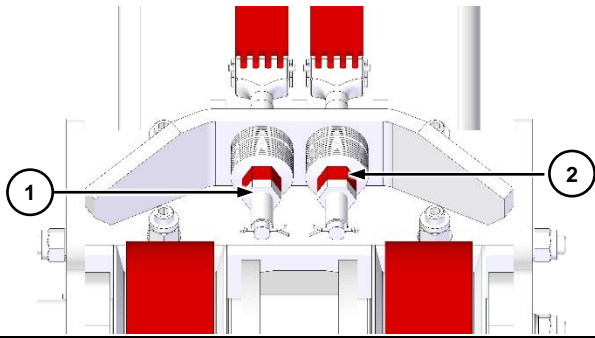

To adjust the chain, first slacken the chain tensioner lock nut ①, then turn nut ② clockwise to increase the chain tension, or anti-clockwise to decrease it.

Measure the distance between the chain axis and the surface of the boom. The reference values are:

- first extension: min. 85 mm, max. 100 mm; (min. 3.34 in, max. 3.93 in)
- second extension: min. 65 mm, max. 80 mm. (min. 2.56 in, max. 3.15 in)
- third extension: min. 70 mm, max. 80 mm. (min. 2.75 in, max. 3.15 in)



WARNING

Take special care to avoid tightening the chains excessively. Breakage of a chain following incorrect adjustment without the dealer's assistance can lead to serious damage.

Checking for wear

To check the chains for wear, the main structural dimensions of the chains of each extension must be known. Take measurements of a new chain or contact your dealer for this information.

Position the vehicle on stabilisers.

Centre the turret and extend the telescopic boom completely in the horizontal position.

Take the measurements on chain sections with 15-18 links. Use the heads of the pins as reference as indicated

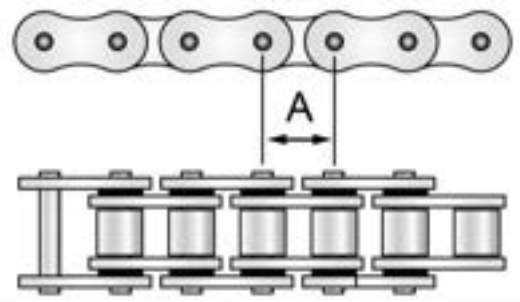

Fleyer chains	Pitch A (mm)	Pitch inch
AL4	12.7	0.5
AL5	15.87	0.6
AL6	19.05	0.7
AL8	25.4	1
AL10	31.75	1.2

NOTICE

If the lengthening of any of the sections is found to be higher than 2% the chain must be replaced.

Repeat the measurements for all the chains. For each chain, take a number of measurements on a number of sections to check non uniform wear. Always take the most worn area as reference.

For replacement of one or more chains, contact your dealer for assistance.

Windscreen washer liquid tank

Filling

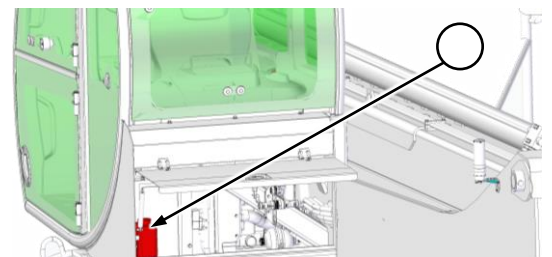

Open the compartment in the rear part of the cab to access the windscreen washing liquid tank housing.

Unscrew the cap by turning it anti-clockwise. Fill the tank with window washing liquid, leaving about 1 cm between the liquid level and the edge.

Refit the cap and tighten it by hand.

Emergency hydraulic pump

Operating test

NOTICE

This model is equipped with an electrically activated emergency hydraulic pump located under the rear casing of the vehicle chassis.

Set the vehicle in the parking position. Extend and lift the telescopic boom. Switch off the engine and turn the ignition key to position I.



Press and lock the switch. Retract and lower the boom to check the correct working of the emergency hydraulic pump.

When the procedure is complete, release the button and switch off the emergency electric pump.



CAUTION

In case of a fault in the emergency hydraulic circuit, avoid using the vehicle and contact your dealer.

Turret rotation slewing ring gear

Lubrication

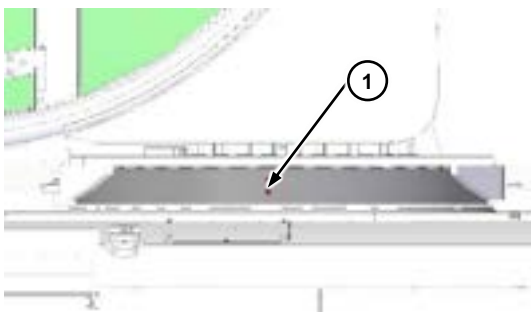

Lubricate both the turret axial bearing tracks by means of the two grease nipples ①. Inject the grease in a number of stages and move the turret to distribute it uniformly.

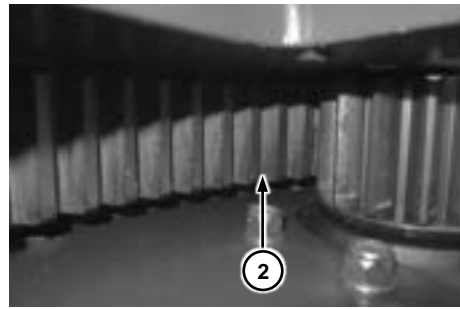

Lift the telescopic boom to access the turret rotation gear.

Lubricate the inner teeth of the fifth wheel ②. Apply grease manually using a brush. Ensure that the grease is distributed uniformly. Remove grease accumulations.

Checking the tightening of the bolts

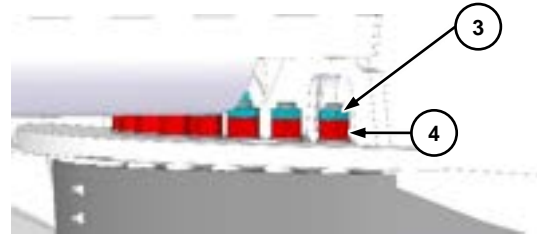

Check the turret fixing nuts on the slewing ring gear. Check for rusted, loose or missing nuts.

Contact your dealer in case of serious problems.

To check the tightening torque loose lock nuts ③. Tighten nuts ④ by applying a 570 Nm torque. Tighten lock nut ③ again. The help of a second operator may be necessary to hold the screw steady.

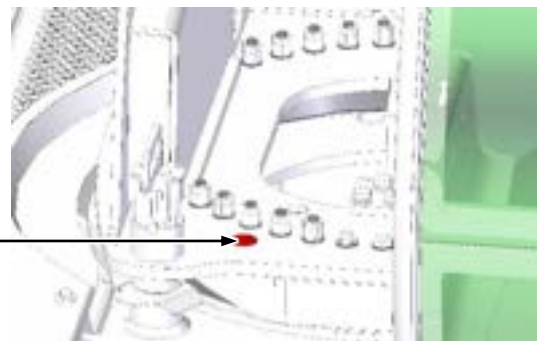

To check the fixing screws of the slewing ring gear on the chassis, align hole ⑤, concealed by a plug, with the screw underneath by rotating the turret.

Tighten the screws by applying a 570 Nm torque. Repeat the operation for each screw, rotating the turret from time to time.

Checking reduction gear oil

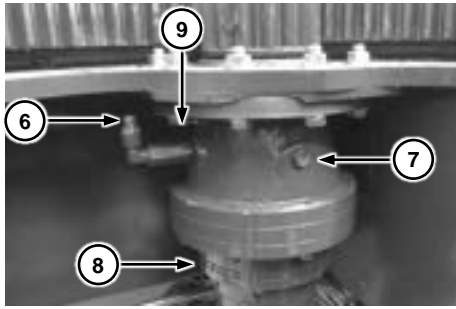

Retract and lift the telescopic boom completely. Rotate the turret to the left by about 60° for better access to the reduction gear.

Check the hydraulic fluid level through the inspection window (7). The level is correct when it overflows.

If necessary, top up with oil of the right strength up to the filler hole (6).

When checking the oil level, also check the bolts fixing the reduction gear to the chassis. In case of faults (rusted, loose or missing bolts), contact your dealer.

**Changing the reduction gear oil
After the first 100 hours and every 500 hours**

Place a suitably sized container under the drainage cap (8). Unscrew the cap and drain out the oil.

Close the drainage cap (8). Add oil through the filler hole (6) until it reaches the prescribed level.

Lubricate the reduction gear shaft bushes by injecting grease into grease nipple (9).

Check slewing gear bearing wear every 500 hours

The factory setting of the play of the bearings is between **0.05 and 0.25 mm (0in)**.

The limit of wear above which the slewing ring gear must be replaced is **2.2 mm (0.08in)**; to check the condition of wear of the bearings, proceed as follows.

Park the vehicle stably on level ground, align the turret to the chassis axis, without load.

Place a measuring device in front of the slewing ring gear with the base on the chassis and measuring needle on the upper surface of the turret.



Lower the boom completely and reset the measuring device to create the reference "0".

Lift the boom all the way to the limit stop and note down the axial play value measured by the measuring device.

The value displayed is the play value.

Batteries

The batteries are located in the central rear part of the vehicle frame and protected by covers; to access them, the turret must be rotated 45° clockwise and the aforementioned cover removed.

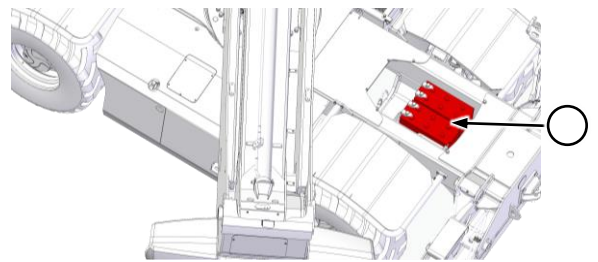

DANGER

Batteries contain acidic and corrosive substances and must be handled with care.

Wear protective clothing such as gloves and safety goggles.

In case of contact with the eyes and/or skin, rinse the affected part of the body immediately and seek medical attention.

DANGER

Batteries contain highly polluting substances which must not be released into the environment.

Proper disposal procedures must be followed for exhausted or damaged batteries.

**DANGER**

Do not recharge damaged batteries.

Do not bring sources of sparks or open flames near batteries: high risk of flammability and explosion.

Do not charge batteries when hot.

- Handle batteries with care: do not turn them upside down or tilt them to avoid spillage of the liquids contained inside.
- Use a voltmeter or densimeter to check the state of charge.
- Do not generate sparks with the cable terminals during charging.
- Check that the caps are correctly fitted and secure.
- In conditions of low use that result in a total discharge of voltage, batteries must be recharged with a suitable instrument or replaced. Do not attempt to charge them with the vehicle's alternator.
- Before any work is carried out, operate the battery disconnect switch to cut power to the vehicle.

NOTICE

For a quick restart of the vehicle in conditions of low battery voltage, it is possible to intervene on the two poles (positive and negative) located next to the battery disconnect switch in the engine compartment without having to access the battery compartment directly.

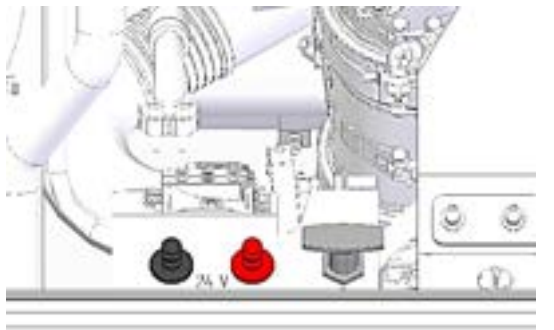

FUSE SECTION

**Internal wiring for standardised cab (p.n. 81789.C) -
Valid for all vehicle models and engines**

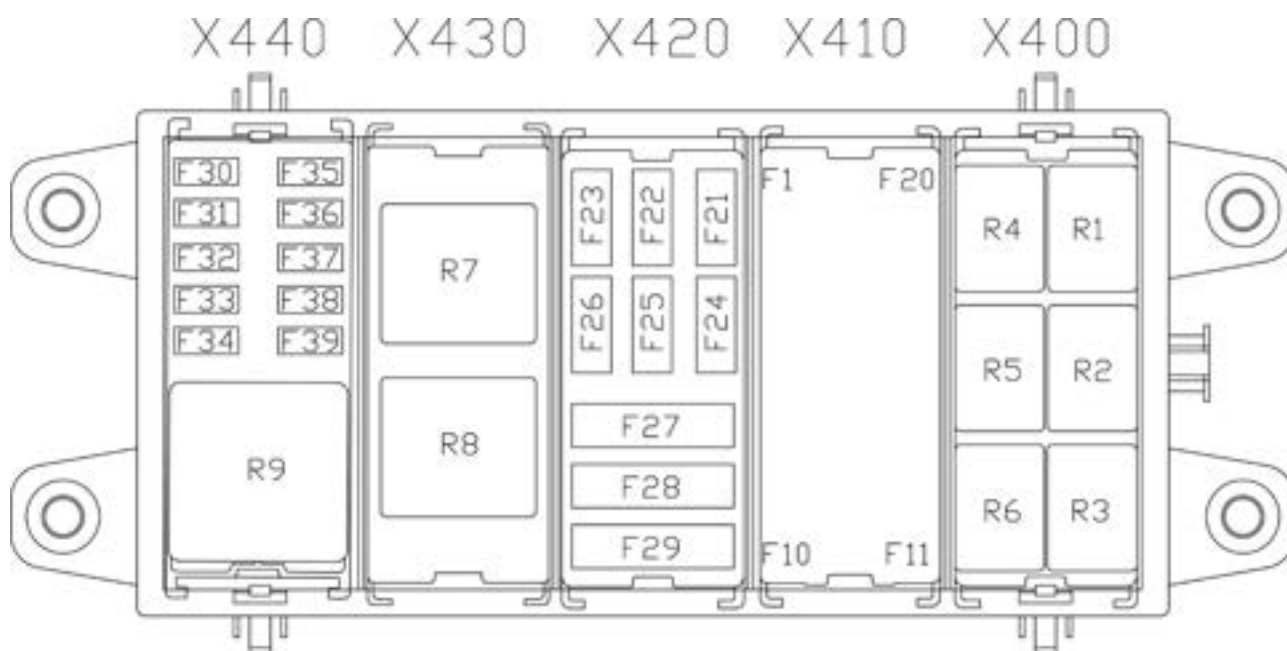

MTA Modules	Component	Characteristics	Function
X400 (6 micro-relay holder module)			
X400/R1		24 V	Start via Trackunit TU501-1
X400/R2		24 V	Front windscreen wiper motor control
X400/R3		24 V	Front windscreen wiper motor control
X400/R4		24 V	Upper windscreen wipers return
X400/R5		24 V	Rear windscreen wiper control
X400/R6		24 V	Emergency button pressed - N.C. pos.
X410 (20-way mini-fuse holder module)			
X410/F1	MINI	15 A	Front windscreen wiper power supply
X410/F2	MINI	15 A	Upper windscreen wiper power supply
X410/F3	MINI	15 A	Rear windscreen wiper power supply
X410/F4	MINI	7.5 A	+15 Front windscreen intermittence
X410/F5	MINI	5 A	+30 Cab LED lights
X410/F6	MINI	7.5 A	Seat power supply
X410/F7	MINI	5 A	+15 Cab auxiliary circuits (USB & WARNING LIGHTS)

MTA Modules	Component	Characteristics	Function
X410/F8	MINI	5 A	+15 Emergency button feedback
X410/F9	MINI	7.5 A	+15 Switches, selectors and buttons
X410/F10	MINI	7.5 A	+15 Sauer Danfoss joystick / +15 Grayhill joystick power supply
X410/F11	MINI	10 A	Centr. output common Turret EXT
X410/F12	MINI	7.5 A	+30 Cab display power supply
X410/F13	MINI	7.5 A	+30 Emergency hazard light switch
X410/F14	MINI	7.5 A	+30 Vehicle radio
X410/F15	MINI	5 A	+15 TUV power supply/+15 Platform guide transducer
X410/F16	MINI	7.5 A	+30 Gateway interface power supply/ +30 power supply XM and TKN
X410/F17	MINI	7.5 A	+15 Trackunit and Gateway
X410/F18	MINI	5 A	+30 Trackunit TU501-1 relay
X410/F19	MINI	7.5 A	+15 J1A Key power supply
X410/F20	MINI	10 A	+30 J1A Key power supply
X420 (9-way fuse holder module (3maxi+6mini))			
X420/F21	ATO	25 A	+15 VP1-VP4 power supply
X420/F22	ATO	25 A	+15 VP2-VP5 power supply
X420/F23	ATO	25 A	+30 VP3-VP6 power supply
X420/F24	ATO	7.5 A	+15 Tower rear EXT control unit power supply
X420/F25	ATO	10 A	Outputs Power Supply EXT
X420/F26	ATO	7.5 A	+15 Sectional power supply optional
X420/F27	MAXI	40 A	+30 Direct from battery
X420/F28	MAXI	40 A	Power supply from battery relay 15 key
X420/F29	MAXI	40 A	Power supply from battery relay 15 sectioned
X430 (1 maxi-relay + 1 mini-relay holder module)			
X430/R7		24 V	+15 Starter panel
X430/R8		24 V	Hazard lights
X440 (10 mini-fuse+ 1 maxi-relay holder module)			
X440/F30	MINI	7.5 A	+15 Danfoss Sauer distributor power supply

<i>MTA Modules</i>	<i>Component</i>	<i>Characteristics</i>		<i>Function</i>
X440/F31	MINI	5 A		+15 Lifting transducer power supply
X440/F32	MINI	5 A		+15 Compensation transducer power supply
X440/F33	MINI	7.5 A		+15 Boom strain gauge power supply
X440/F34	MINI	5 A		+15 Turret inclinometer power supply
X440/F35	MINI	15 A		+15 Vehicle radio
X440/F36	MINI	10 A		+15 Boom head functions
X440/F37	MINI	5 A		+15 Rotary encoder power supply
X440/F38	MINI	5 A		+15 Rear video camera power supply/ positive "15" setup
X440/F39	MINI	7.5 A		+15 Light switch/windscreen wiper/horn power supply
X440/R9		24 V		Emergency button pressed - N.C. pos.

Key of fuses/relays - Logic Box (p.n. 81794.A) for vehicle models with continuous rotation equipped with 100 kW - Stage V engine and Sauer Danfoss transmission

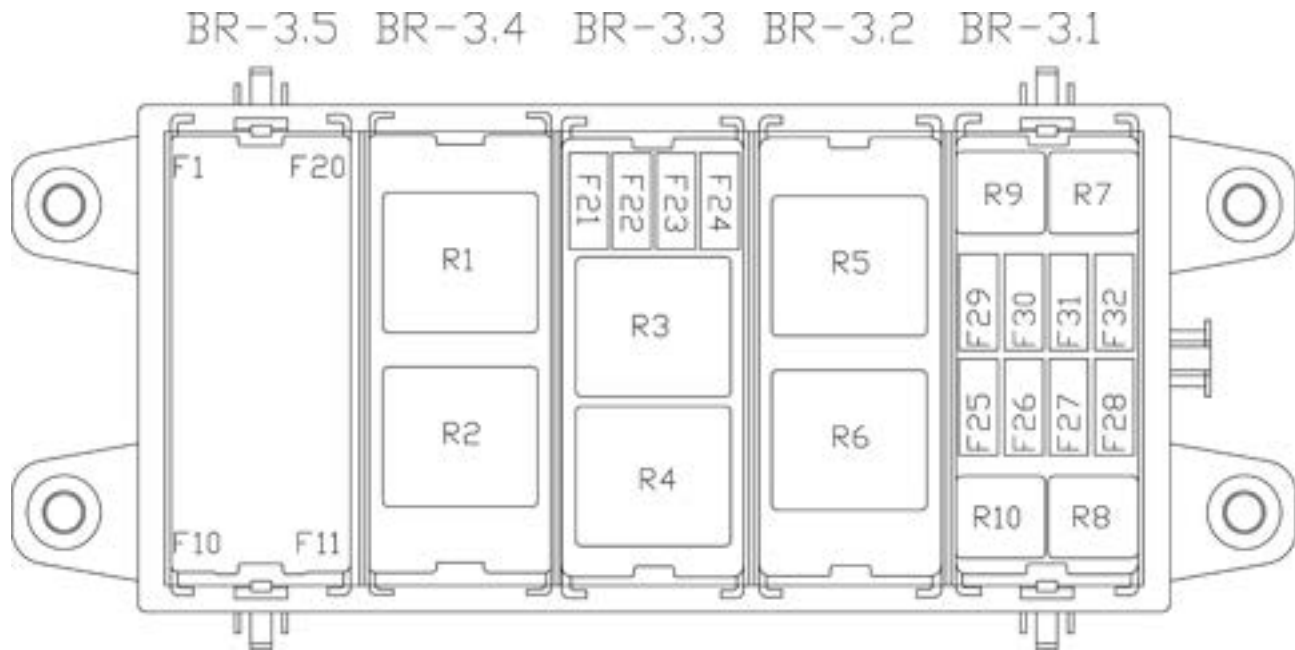

MTA Modules	Component	Characteristics	Function
BR-3.5 (20-way mini-fuse holder module)			
BR-3.5/F1	MINI	5 A	+30 Rear setup
BR-3.5/F2	MINI	10 A	+30 J1A power supply
BR-3.5/F3	MINI	7.5 A	+15 J1A power supply
BR-3.5/F4	MINI	25 A	+15 VP1-VP4 power supply
BR-3.5/F5	MINI	25 A	+15 VP2-VP5 power supply
BR-3.5/F6	MINI	25 A	+15 VP3-VP6 power supply
BR-3.5/F7	MINI	5 A	+15 Parking brake bulb key
BR-3.5/F8	MINI	20 A	+15 Danfoss control unit power supply
BR-3.5/F9	MINI	5 A	+15 Raised stabilisers proximity switches power supply
BR-3.5/F10	MINI	5 A	+15 Stabiliser extension transducer power supply
BR-3.5/F11	MINI	5 A	+15 Raised stabilisers proximity switches power supply
BR-3.5/F12	MINI	5 A	+15 Stabiliser extension transducer power supply
BR-3.5/F13	MINI	7.5 A	+15 Setup 1
BR-3.5/F14	MINI	7.5 A	+15 Setup 2
BR-3.5/F15	MINI	7.5 A	+15 IN/OUT setup

<i>MTA Modules</i>	<i>Component</i>	<i>Characteristics</i>	<i>Function</i>
<i>BR-3.5/F16</i>	MINI	7.5 A	+15 Proximity sensor power supply
<i>BR-3.5/F17</i>	MINI	7.5 A	+15 Differential lock power supply
<i>BR-3.5/F18</i>	MINI	7.5 A	+15 Engine setup
<i>BR-3.5/F19</i>	MINI	10 A	+15 Trinary air conditioning
<i>BR-3.5/F20</i>	MINI	10 A	Emergency button pressed - N.C. pos.
<i>BR-3.4 (2 maxi-relay module)</i>			
<i>BR-3.4/R1</i>		24 V	+15 Key for control unit
<i>BR-3.4/R2</i>		24 V	Cut. Power supply from emergency button after fuse
<i>BR-3.3 (2 mini-relay + 4 mini-fuse module)</i>			
<i>BR-3.3/F21</i>	MINI	25 A	+30 R3 relay
<i>BR-3.3/F22</i>	MINI	25 A	+30 R4 relay
<i>BR-3.3/F23</i>	MINI	5 A	Alternator warning light after fuse
<i>BR-3.3/F24</i>	MINI	7.5 A	+15 Trailer setup power supply
<i>BR-3.3/R3</i>		24 V	2nd hydraulic fluid fan
<i>BR-3.3/R4</i>		24 V	1st hydraulic fluid fan
<i>BR-3.2 (1 maxi-relay + 1 mini-relay module)</i>			
<i>BR-3.2/R5</i>		24 V	+15 Starter key
<i>BR-3.2/R6</i>		24 V	Stabiliser cut-off relay
<i>BR-3.1 (4 micro-relays + 8 mini-relays module)</i>			
<i>BR-3.1/F25</i>	MINI	10 A	+30 Stop light relay
<i>BR-3.1/F26</i>	MINI	7.5 A	+30 R8 relay
<i>BR-3.1/F27</i>	MINI	15 A	+30 R9 relay
<i>BR-3.1/F28</i>	MINI	15 A	+30 R10 relay
<i>BR-3.1/F29</i>	MINI	7.5 A	+15 Road traffic sensor
<i>BR-3.1/F30</i>	-	-	-
<i>BR-3.1/F31</i>	-	-	-
<i>BR-3.1/F32</i>	-	-	-
<i>BR-3.1/R7</i>		24 V	+30 Stop light relay
<i>BR-3.1/R8</i>		24 V	86 R8 relay
<i>BR-3.1/R9</i>		24 V	86 R9 relay
<i>BR-3.1/R10</i>		24 V	86 R10 relay

Key of fuses/relays - Logic Box (p.n. 85860.A) for vehicle models with continuous rotation equipped with 100 kW - Stage IIIA engine and Sauer Danfoss transmission

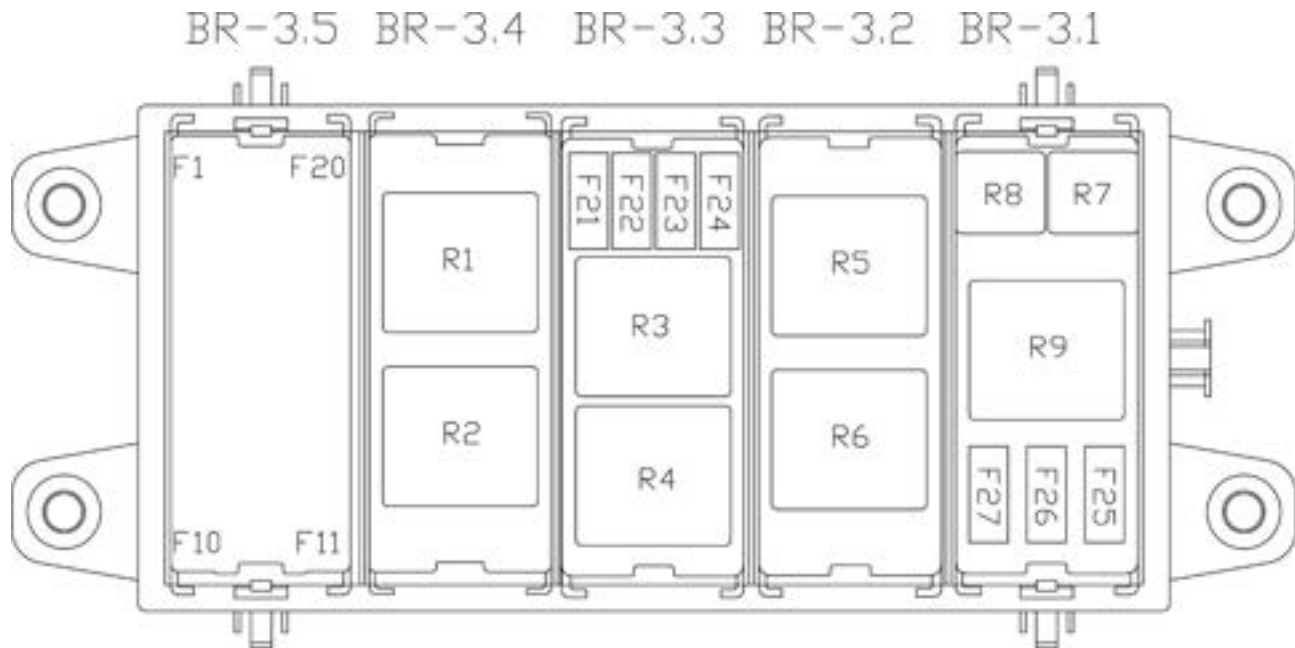

MTA Modules	Component	Characteristics	Function
BR-3.5 (20-way mini-fuse holder module)			
BR-3.5/F1	MINI	5 A	+30 Rear setup
BR-3.5/F2	MINI	10 A	+30 J1A power supply
BR-3.5/F3	MINI	7.5 A	+15 J1A power supply
BR-3.5/F4	MINI	5 A	Stop light relays
BR-3.5/F5	MINI	7.5 A	Reversing light relays
BR-3.5/F6	MINI	15 A	+15 Electrical fuel pump power supply
BR-3.5/F7	MINI	5 A	+15 Switch on Bosch Rexroth
BR-3.5/F8	MINI	20 A	+15 Danfoss Sauer control unit power supply
BR-3.5/F9	MINI	5 A	+15 Raised stabilisers proximity switches power supply
BR-3.5/F10	MINI	5 A	+15 Stabiliser extension transducer power supply
BR-3.5/F11	MINI	5 A	+15 Raised stabilisers proximity switches power supply
BR-3.5/F12	MINI	5 A	+15 Stabiliser extension transducer power supply
BR-3.5/F13	MINI	7.5 A	+15 Setup 1
BR-3.5/F14	MINI	7.5 A	+15 Setup 2
BR-3.5/F15	MINI	7.5 A	+15 IN/OUT setup

MTA Modules	Component	Characteristics	Function
<i>BR-3.5/F16</i>	MINI	7.5 A	+15 Proximity sensor power supply
<i>BR-3.5/F17</i>	MINI	7.5 A	+15 Differential lock power supply
<i>BR-3.5/F18</i>	MINI	5 A	+15 Road traffic sensor
<i>BR-3.5/F19</i>	MINI	10 A	+15 Trinary air conditioning
<i>BR-3.5/F20</i>	MINI	10 A	Power supply interruption from emergency button after fuse
<i>BR-3.4 (2 maxi-relay module)</i>			
<i>BR-3.4/R1</i>		24 V	+15 Key for Control Unit
<i>BR-3.4/R2</i>		24 V	Power supply interruption from emergency button After fuse
<i>BR-3.3 (2 mini-relay + 4 mini-fuse module)</i>			
<i>BR-3.3/F21</i>	MINI	25 A	+30 R3 relay
<i>BR-3.3/F22</i>	MINI	25 A	+30 R4 relay
<i>BR-3.3/F23</i>	MINI	5 A	Alternator warning light after fuse
<i>BR-3.3/F24</i>	MINI	7.5 A	+15 Trailer setup power supply
<i>BR-3.3/R3</i>		24 V	2nd hydraulic fluid fan
<i>BR-3.3/R4</i>		24 V	1st hydraulic fluid fan
<i>BR-3.2 (1 maxi-relay + 1 mini-relay module)</i>			
<i>BR-3.2/R5</i>		24 V	+15 Starter key
<i>BR-3.2/R6</i>		24 V	Stabiliser cut-off relay
<i>BR-3.1 (2 micro-relay + 1 maxi-relay + 3 maxicompact fuses module)</i>			
<i>BR-3.1/F25</i>	MAXICOMPACT	25 A	+15 Power supply VP1-VP4
<i>BR-3.1/F26</i>	MAXICOMPACT	25 A	+15 Power supply VP2-VP5
<i>BR-3.1/F27</i>	MAXICOMPACT	25 A	+15 Power supply VP3-VP6
<i>BR-3.1/R7</i>		24 V	Stop light relays
<i>BR-3.1/R8</i>		24 V	Reversing light output
<i>BR-3.1/R9</i>		24 V	Electrical fuel pump relay K3 High

Key of fuses/relays - Logic Box (p.n. 84016.C) for vehicle models with limited rotation equipped with 55.4 kW Stage V/ Stage IIIA engine and Bosch Rexroth transmission

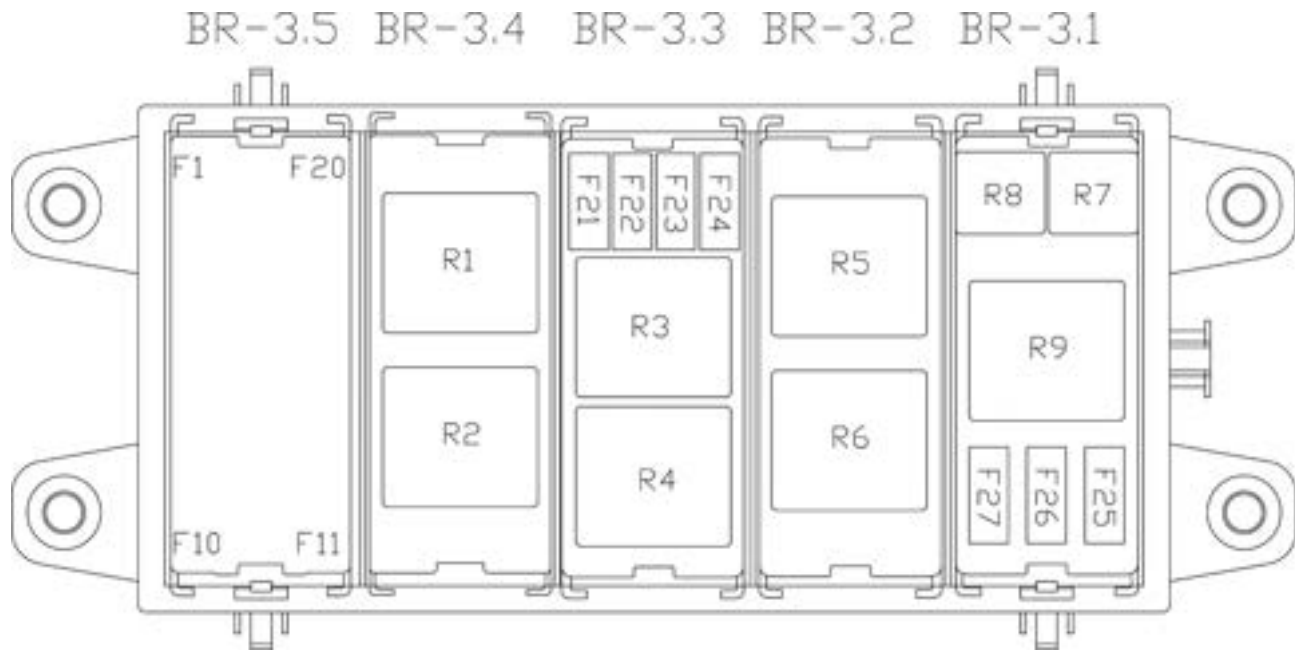

MTA Modules	Component	Characteristics	Function
BR-3.5 (20-way mini-fuse holder module)			
BR-3.5/F1	MINI	5 A	+30 Rear setup
BR-3.5/F2	MINI	10 A	+30 J1A power supply
BR-3.5/F3	MINI	7.5 A	+15 J1A power supply
BR-3.5/F4	MINI	5 A	Stop light relays
BR-3.5/F5	MINI	7.5 A	Reversing light relays
BR-3.5/F6	MINI	15 A	+15 Electrical fuel pump power supply
BR-3.5/F7	MINI	5 A	+15 Switch on Bosch Rexroth
BR-3.5/F8	MINI	20 A	+30 Bosch Rexroth control unit power supply
BR-3.5/F9	MINI	5 A	+15 Raised stabilisers proximity switches power supply
BR-3.5/F10	MINI	5 A	+15 Stabiliser extension transducer power supply
BR-3.5/F11	MINI	5 A	+15 Raised stabilisers proximity switches power supply
BR-3.5/F12	MINI	5 A	+15 Stabiliser extension transducer power supply
BR-3.5/F13	MINI	7.5 A	+15 Setup 1
BR-3.5/F14	MINI	7.5 A	+15 Emergency button signal for control units
BR-3.5/F15	MINI	7.5 A	+15 IN/OUT setup

MTA Modules	Component	Characteristics	Function
<i>BR-3.5/F16</i>	MINI	7.5 A	+15 Proximity sensor power supply
<i>BR-3.5/F17</i>	MINI	7.5 A	+15 Differential lock power supply
<i>BR-3.5/F18</i>	MINI	5 A	+15 Road traffic sensor
<i>BR-3.5/F19</i>	MINI	10 A	+15 Trinary air conditioning
<i>BR-3.5/F20</i>	MINI	10 A	Cut. Power supply from emergency button after fuse
<i>BR-3.4 (2 maxi-relay module)</i>			
<i>BR-3.4/R1</i>		24 V	+15 Key for control unit
<i>BR-3.4/R2</i>		24 V	Cut. Power supply from emergency button after fuse
<i>BR-3.3 (2 mini-relay + 4 mini-fuse module)</i>			
<i>BR-3.3/F21</i>	MINI	25 A	+30 R3 relay
<i>BR-3.3/F22</i>	MINI	25 A	+30 R4 relay
<i>BR-3.3/F23</i>	MINI	5 A	Alternator warning light after fuse
<i>BR-3.3/F24</i>	MINI	7.5 A	+15 Power supply Trailer setup
<i>BR-3.3/R3</i>		24 V	2nd hydraulic fluid fan
<i>BR-3.3/R4</i>		24 V	1st hydraulic fluid fan
<i>BR-3.2 (1 maxi-relay + 1 mini-relay module)</i>			
<i>BR-3.2/R5</i>		24 V	+15 Starter key
<i>BR-3.2/R6</i>		24 V	Stabiliser cut-off relay
<i>BR-3.1 (2 micro-relay + 1 maxi-relay + 3 maxcompact fuses module)</i>			
<i>BR-3.1/F25</i>	MAXICOMPACT	25 A	+15 Power supply VP1-VP4
<i>BR-3.1/F26</i>	MAXICOMPACT	25 A	+15 Power supply VP2-VP5
<i>BR-3.1/F27</i>	MAXICOMPACT	25 A	+15 Power supply VP3-VP6
<i>BR-3.1/R7</i>		24 V	Stop light relays
<i>BR-3.1/R8</i>		24 V	Reversing light output
<i>BR-3.1/R9</i>		24 V	Electrical fuel pump relay K3 High

TROUBLESHOOTING

Error and display messages

<i>Message</i>	<i>Causes</i>	<i>Solutions</i>
<i>Boom height</i>	Movement on wheels was attempted with "hare" mode activated and boom height greater than 3 m	Lower the telescopic boom or activate the "tortoise" mode
<i>Boom angle</i>	Movement on wheels was attempted with "hare" mode activated and boom angle greater than 35°	Lower the telescopic boom or activate the "tortoise" mode
<i>Turret rotation angle</i>	Stabilisers lift command with turret not aligned	Position the turret at 0° before activating the stabilisers lift command
<i>Movement block by load limiter</i>	Hydraulic movement imparted at load chart limit Error in the safety system	Retract and/or lift the boom to restore the load to safety Check errors in alarms page
<i>Double movement not allowed</i>	Simultaneous actuation of two hydraulic movements (e.g. boom and stabilisers) not allowed	Carry out the hydraulic movements separately
<i>Stabilisers microswitch error</i>	Inconsistency between main switch of stabilisers and redundant	Check errors in alarms page
<i>Boom ascent limit stop</i>	Mechanical limit stop of boom ascent has been reached	Do not insist with the command
<i>Parking brake applied</i>	Attempt to move on wheels with parking brake applied	Deactivate the parking brake
<i>Platform height limitation</i>	Height of lift platform above ground excessive for movement on wheels	Operate the vehicle on wheels with the platform within the safety limit of 3 m height from the ground
<i>Platform microswitch</i>	Lift platform overload	Do not load platform beyond the permitted capacity
<i>Insert accessory block pin</i>	Shear pin not inserted with lift platform fitted Shear pin not detected	Insert the shear pin Check the shear pin detection switch
<i>Axle not aligned</i>	Front/rear axle not centred	Align front and/or rear wheels correctly. Check axles alignment sensors
<i>Levelling in progress</i>	Warning of levelling operation on stabilisers in progress	No action required

Message	Causes	Solutions
<i>Boom length</i>	Actuation of stabilisers with excessive boom extension Lift platform movement on wheels with excessive boom extension	Retract the telescopic boom until the error message disappears
<i>Seat microswitch</i>	Movement on wheels or a hydraulic command attempted with operator not seated Seat switch defective	Sit properly in the driver's seat Check the seat switch
<i>Press dead man's joystick</i>	Hydraulic command given by means of joystick without pressing movement enable button	Press the movement enabling button to confirm voluntary activation of command
<i>Engine compartment open</i>	Engine compartment opened during working with engine switched off automatically Engine compartment switch defective	Check the engine compartment to be able to start up the engine Check the engine compartment switch
<i>Engine at minimum speed</i>	Gear change lever operated with engine not at minimum speed	Bring the engine to minimum speed before changing gears
<i>Brake pedal not pressed</i>	Gear change lever operated with brake pedal not pressed	Press the service brake pedal before changing gears
<i>Vehicle running</i>	Impossible to change mode	Stop the vehicle and change the operating mode
<i>Emergency pump activated</i>	Emergency hydraulic pump activated warning	No action required
<i>Radio control on</i>	Hydraulic command given from cab with radio control active	Disconnect the radio control to operate the vehicle from the cab
<i>Selector not in neutral</i>	Gear change lever not in neutral position	Set the lever in the neutral position
<i>Extend stabilisers</i>	Attempt to retract the stabilisers when not completely lifted	Lift the stabilisers completely before retracting them
<i>Levelling timeout</i>	Automatic levelling operation within 60 seconds failed	Interrupt the command

Engine troubleshooting

Engine – does not switch on or switching on is difficult (no fumes at exhaust)

Cause	Solution
Ignition switch defective	Check the opening and closing of the electric connection.
Fuel filter clogged	Bleed the water separator or replace the filter.
Fuel priming pump defective	Check to make sure the pump provides the flow rate suitable for the high pressure pump. Check the electrical connections.
Air in the fuel	Check the absence of air returning to the circuit
Fuel dirty or non conforming	SWITCH THE ENGINE OFF. Replace the fuel filters. Run the engine with correct fuel.
Suction or discharge system obstructed	Visually inspect the suction and discharge, and remove any obstructions present. Replace the air filter if necessary
Fuel return line blocked	Check to make sure the line is clear and connected to the upper part of the tank
Fault in one or more injectors	Check the electrical connections.
ECU or sensors fault	Check the electrical connections.

Engine – does not turn when started up or moves slowly

Cause	Solution
Electrical circuit elements loose or worn	Clean and carry out the necessary maintenance
Battery flat	Check the voltage using a multimeter. Check the working of the alternator.
Solenoid or starter motor fault	Replace the starter motor
Starter motor working but the engine does not rotate	Remove the starter motor and check the state of the gears and spring

Engine – starts up but switches off immediately

Cause	Solution
No fuel in tank	Refuel.
Starter motor charged	Check the presence of external loads due to faulty auxiliaries.
Suction or discharge system obstructed	Visually inspect the suction and discharge, and remove any obstructions present. Replace the air filter if necessary

Cause	Solution
Fuel priming pump defective	Check to make sure the pump provides the flow rate suitable for the high pressure pump. Check the electrical connections.
Fuel frozen	Use fuels suitable for low temperatures
Air in the fuel	Check the absence of air returning to the circuit
Fuel dirty or non conforming	SWITCH THE ENGINE OFF. Replace the fuel filters. Run the engine with correct fuel.
Fuel supply obstructed	Check for blockage along the line. Check the state of the filters and replace if necessary.
Fuel return line blocked	Check to make sure the line is clear and connected to the upper part of the tank
ECU or sensors fault	Check the electrical connections.

Engine – irregular operation

Cause	Solution
Engine cold, or coolant temperature sensor fault	Check the sensor electrical connection. Check the working of the sensor.
Leakage in fuel circuit	Replace the defective connections. DO NOT try to carry out repairs.
Air in the fuel	Check the absence of air returning to the circuit
Fuel priming pump defective	Check to make sure the pump provides the flow rate suitable for the high pressure pump. Check the electrical connections.
Fuel supply obstructed	Check for blockage along the line. Check the state of the filters and replace if necessary.
Fuel dirty or non conforming	SWITCH THE ENGINE OFF. Replace the fuel filters. Run the engine with correct fuel.
Incorrect adjustment of valve play	Correct the adjustment
Compression not good in one or more cylinders	Check the compression ratio
ECU or sensors fault	Check the electrical connections.

Engine – excessive noise

Cause	Solution
Slipping of transmission belt, tension insufficient or excessive	Check the belt tensioner and inspect the belt. Make sure the pulley rotation is not hindered
Coolant temperature sensor fault	Check the sensor electrical connection. Check the working of the sensor.
Fuel dirty or non conforming	SWITCH THE ENGINE OFF. Replace the fuel filters. Run the engine with correct fuel.
Incorrect adjustment of valve play	Correct the adjustment. Make sure the rod and equaliser mechanism is not damaged or worn
Noise coming from engine block	Contact your dealer immediately

Engine – reduced power

Cause	Solution
No fuel in tank	Refuel.
Oil level not correct	Check the level
Engine overload	Check the presence of overloads due to faulty auxiliary parts
Fuel dirty or non conforming	SWITCH THE ENGINE OFF. Replace the fuel filters. Run the engine with correct fuel.
Fault in turbocompressor	Contact your dealer
Leakage in fuel circuit	Replace the defective connections. DO NOT try to carry out repairs.
Fuel supply obstructed	Check for blockage along the line. Check the state of the filters and replace if necessary.
Air in the fuel	Check the absence of air returning to the circuit
Fuel priming pump defective	Check to make sure the pump provides the flow rate suitable for the high pressure pump. Check the electrical connections.
Suction or discharge system obstructed	Visually inspect the suction and discharge, and remove any obstructions present. Replace the air filter if necessary
Fault in one or more injectors	Check the electrical connections.
Leaks in manifolds or in turbocompressor	Check and correct leaks in the manifolds
Too many sealing washers installed under the injectors	Remove the excess sealing washers
Incorrect adjustment of valve play	Correct the adjustment
Compression not good in one or more cylinders	Check the compression ratio

Engine – does not reach the maximum rpm

Cause	Solution
Speedometer defective	Check the engine speed using a manual speedometer. Correct if necessary
Engine overload	Check the presence of overloads due to faulty auxiliary parts
Fuel dirty or non conforming	SWITCH THE ENGINE OFF. Replace the fuel filters. Run the engine with correct fuel.
Wastegate valve actuator diaphragm cracked	Repair or replace the turbocompressor
Leakage in fuel circuit	Replace the defective connections. DO NOT try to carry out repairs.
Fuel supply obstructed	Check for blockage along the line. Check the state of the filters and replace if necessary.
Fuel priming pump defective	Check to make sure the pump provides the flow rate suitable for the high pressure pump. Check the electrical connections.
Fault in one or more injectors	Check the electrical connections
Fuel high pressure pump fault	Contact your dealer

Engine – excessive vibrations

Cause	Solution
Oil level excessive	Check the level
Fan damaged or auxiliaries fault	Replace the defective components
Fan hub damaged	Check and replace the hub
Engine supports loose or damaged	Tighten the loose supports and replace those that are damaged
Incorrect adjustment of valve play	Correct the adjustment
Compression not good in one or more cylinders	Check the compression ratio
Alternator bearing worn	Check/replace the alternator

Engine – black fumes at the exhaust

Cause	Solution
Suction or discharge system obstructed	Visually inspect the suction and discharge, and remove any obstructions present. Replace the air filter if necessary
Leaks between the turbocompressor and suction manifold	Inspect and repair the leaks
Intercooler defective	Check the radiator mass
Leaks from discharge manifolds or from turbocompressor	Repair the leaks from the gaskets. Check for cracks in the connections
Wastegate valve fault	Replace the valve
Turbocompressor fault	Replace
Fault in one or more injectors	Check the electrical connections
Compression not good in one or more cylinders, fumes with load mainly at average and low speeds	Contact your dealer

Engine - white fumes at the exhaust

Cause	Solution
Fuel dirty or non conforming	SWITCH THE ENGINE OFF. Replace the fuel filters. Run the engine with correct fuel.
Oil level not correct	Check the level
Diesel and hydraulic fluid in engine casing	If the oil is contaminated, check the gaskets at the power take-offs. Drain oil, clean and refill with fresh oil.
Leaks from seals in the valve seats – evident after long periods at minimum speed followed by sudden acceleration	Contact your dealer
Fault in one or more injectors	Check the electrical connections
Piston belts not sealed – blue fumes at all speeds	Contact your dealer

 Fuel – excessive consumption

Cause	Solution
Additional loads on the engine	Check/repair the auxiliaries and equipment of the slewing variable-reach truck
Fuel leaks	Check for leaks near the tank, fuel line, filters and priming pump. DO NOT try to repair the defective piping
Control unit defective	Contact your dealer
Fault in one or more injectors	Check the electrical connections
Incorrect adjustment of valve play	Correct the adjustment

Fuel/oil – leaks from the drainage

Cause	Solution
Turbocompressor lubrication line obstructed	Check and clean the piping
Leaks from discharge manifolds or from turbocompressor	Repair the leaks from the gaskets. Check for cracks in the connections
Leaks from the valve guides	Contact your dealer
Control unit defective	Contact your dealer
Fault in one or more injectors	Check the electrical connections

Lubricant – excessive consumption

Cause	Solution
Oil leaks	Check the engine for leaks
Lubricant specifications unsuitable	Make sure a suitable lubricant is used. Check contamination by fuel
Leaks in cooling system	Check for the presence of lubricating oil in the coolant
Leaks from turbocompressor in the suction or discharge system	Check for leaks
Leaks from the valve guides	Contact your dealer
Cylinders worn or damaged	Contact your dealer

Lubricant - contamination

Cause	Solution
Impurities in lubricating oil	Change the oil and filters. If operating in particularly heavy duty conditions, increase the maintenance frequency. Make sure a suitable lubricant is used
Fuel in lubricant oil, engine temperature very low	Avoid leaving the engine running at low speed for too long

Lubricant - pressure excessively low

Cause	Solution
Oil level not correct	Check the level
Lubricant specifications unsuitable	Make sure a suitable lubricant is used. Check contamination by fuel
Pressure gauge fault	Check the correct working
Oil filter clogged	Change the oil and filters. If operating in particularly heavy duty conditions, increase the maintenance frequency. Make sure a suitable lubricant is used
The oil priming pump pressure limiter valve is blocked in the open position	Contact your dealer
The oil pump pressure limiter valve is blocked in the open position	Contact your dealer
Oil pump worn	Contact your dealer

Lubricant – excessive pressure

Cause	Solution
Lubricant specifications unsuitable	Make sure a suitable lubricant is used. Check contamination by fuel
Pressure gauge fault	Check the correct working
The oil pump pressure limiter valve is blocked in the closed position	Contact your dealer

Coolant - leaks

Cause	Solution
Coolant level not correct	Check the level
Liquid leaks from radiator	Check the radiator, hoses and piping for leaks
Liquid leaks from engine	Check the engine for leaks from gaskets, pipes or unions. Make sure all the clamps are tightened properly and in good condition
Leaks from the head gasket	Contact your dealer
Engine head cracked or shows porosity	Contact your dealer
Leaks from lubricant passages in the base	Contact your dealer

Coolant - overheating

Cause	Solution
Coolant level not correct (low)	Check the level
Radiator grille obstructed	Clean the radiator grille
Air flow to radiator insufficient or obstructed	Check/repair the fan
Belt tension insufficient	Check the tension
Radiator pipe crushed, obstructed or cracked	Check/replace the defective tube
Oil level not correct (high)	Check the level
Radiator cap defective	Replace the radiator cap
Excessive concentration of antifreeze	Drain part of the circuit and fill with distilled water
Temperature sensor defective	Check the accuracy of the sensor
Thermostat faulty or missing	Check/replace the thermostat
Coolant pump faulty	Check/replace the pump
Passage of liquid through the radiator, head or engine block obstructed	Wash the plant with distilled water and fill with fresh coolant

Coolant – not at required temperature

Cause	Solution
Temperature sensor defective	Check the accuracy of the sensor
Thermostat defective (blocked open)	Check/replace the thermostat
Liquid not circulating near the temperature sensor	Check/clean the liquid passages

VEHICLE STORAGE

Leaving the vehicle unused for long periods

If the vehicle is to be left unused for more than 30 days, carry out certain operations to keep it in good condition and maintain a high level of service.

Leaving the vehicle unused for less than 12 months

Park the vehicle in a well ventilated area, free of humidity and protected from atmospheric agents. Make sure the environmental temperature in the area does not fall below -10°C (14°F).

Clean the vehicle thoroughly. Remove all traces of rust or corrosion. Touch up the paint layer in the areas concerned.

Change the engine oil and the filter if the oil is more than 12 months old or after 300 hours of service after the last change.

Charge the batteries. Check the level of electrolyte before and after charging. Disconnect the negative pole after the charging.

Check the coolant level and top up if necessary.

Check the pressure in the AdBlue[®] circuit pressure accumulator.

Drain water from the fuel prefilter with water/fuel separator.

Close the drainage pipe and the air intake in the filter casing with rags soaked in oil.

Loosen the belt tensioner device in the transmission belt. Do not dismantle the transmission belt completely.

Leaving the vehicle unused for less than 36 months

If the vehicle is to be left unused for more than 12 months and less than 36 months, certain protective measures must be adopted in addition to those required for leaving the vehicle unused for less than 12 months.

Fill the fuel tank completely. Run the engine for 15 – 30 minutes at not more than 900 rpm.

Disconnect the suction manifolds from the top of the engine. Press the start button present on each engine briefly and at the same time pour about 15 cc of oil in each cylinder.

Pour about 5cc of oil in the volumetric compressor on the suction side.

Refit all the components and tighten the fixing screws applying the correct tightening torque.

Reusing the vehicle

Clean the fuel tank. Refuel.

Replace the fuel prefilter and filter.

Check the coolant level. If topping up is necessary, take a sample of the liquid and check the composition. Add distilled water or pure liquid to adjust the composition.

Check the battery charge. Charge if necessary. Check the level of electrolyte before and after charging. Again connect the negative pole to the batteries. Check the electrical system to make sure it is working correctly.

Check the condition of the transmission belt. Replace if necessary. Restore the working of the belt tensioner device.

Start up the engine and let it run for 15 – 30 minutes at not more than 900 rpm. Keep the oil pressure, water temperature and oil temperature indicators under observation.

Check the oil level in the axles, in the wheel reduction gears and in the gearbox.

Dismantling and disposal of the vehicle

By the time the vehicle is taken out of service, the reference standards will have changed. The procedures for dismantling and scrapping the vehicle vary according to the regulatory standards in force in the country in which it is used. For information regarding dismantling and scrapping the vehicle, contact your dealer for updates regarding the directives in force.

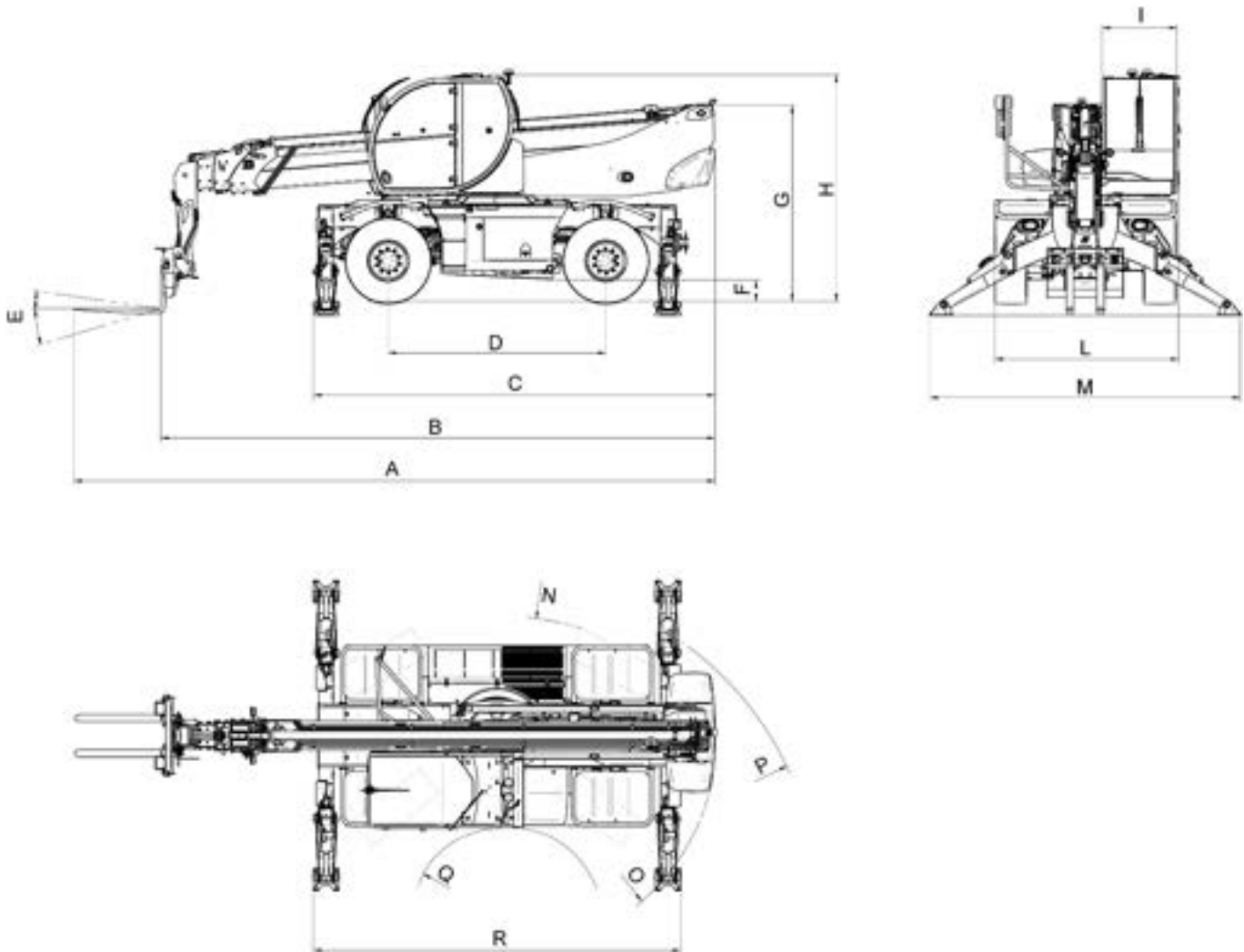
DIMENSIONS**RTH 5.18 – RTH 5.21 – RTH 5.23 - RTH 5.25**

	RTH 5.18	RTH 5.21	RTH 5.23	RTH 5.25
A	8000 mm 314.96"	7810 mm 307.48"	8390 mm 330.31"	8840 mm 348.03"
B	6800 mm 267.72"	6610 mm 260.24"	7190 mm 283.07"	7640 mm 300.79"
C	5170 mm 203.54"	5170 mm 203.54"	5530 mm 217.72"	5540 mm 218.11"
D	3000 mm 118.11"	3000 mm 118.11"	3000 mm 118.11"	3000 mm 118.11"
E	135° (+8° / -127°)	135° (+8° / -127°)	135° (+8° / -127°)	135° (+8° / -127°)
F	300 mm 11.81"	300 mm 11.81"	300 mm 11.81"	300 mm 11.81"
G	2715 mm 106.89"	2715 mm 106.89"	2715 mm 106.89"	2715 mm 106.89"
H	3120 mm 122.83"	3120 mm 122.83"	3120 mm 122.83"	3120 mm 122.83"
I	1030 mm 40.55"	1030 mm 40.55"	1030 mm 40.55"	1030 mm 40.55"
L	2530 mm 99.61"	2530 mm 99.61"	2530 mm 99.61"	2530 mm 99.61"
M	4270 mm 168.11"	4270 mm 168.11"	4270 mm 168.11"	4270 mm 168.11"
N	R 3980 mm 156.69"	R 3980 mm 156.69"	R 3990 mm 157.09"	R 3990 mm 157.09"
O	R 2650 mm 104.33"	R 2650 mm 104.33"	R 3030 mm 119.29"	R 3030 mm 119.29"
P	R 4430 mm 174.41"	R 4430 mm 174.41"	R 4430 mm 174.41"	R 4430 mm 174.41"
Q	1455 mm 57.28"	1455 mm 57.28"	1455 mm 57.28"	1455 mm 57.28"
R	5060 mm 199.21"	5060 mm 199.21"	5060 mm 199.21"	5060 mm 199.21"

RTH 6.22 - RTH 6.26

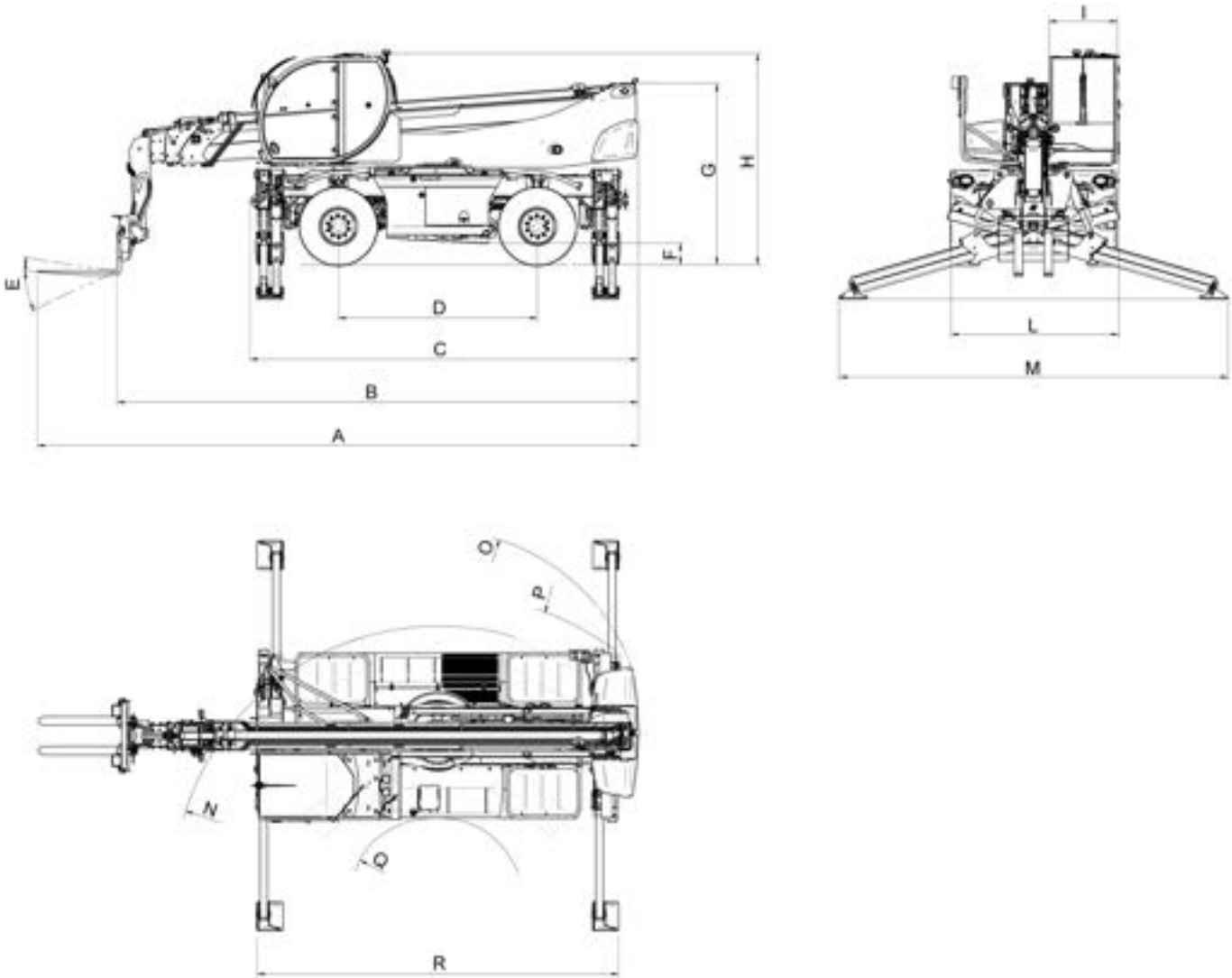

	RTH 6.22	RTH 6.26
A	8240 mm 324.41"	9050 mm 356.30"
B	7040 mm 277.17"	7850 mm 309.06"
C	5700 mm 224.41"	5850 mm 230.31"
D	3000 mm 118.11"	3000 mm 118.11"
E	133° (+8° / -125°)	133° (+8° / -125°)
F	330 mm 12.30"	330 mm 12.30"
G	2730 mm 107.48"	2730 mm 107.48"
H	3120 mm 122.83"	3120 mm 122.83"
I	1030 mm 40.55"	1030 mm 40.55"
L	2530 mm 99.61"	2530 mm 99.61"
M	5870 mm 231.10"	5870 mm 231.10"
N	R 3970 mm 156.30"	R 3990 mm 157.09"
O	R 2840 mm 111.81"	R 3090 mm 121.65"
P	R 4490 mm 176.77"	R 4490 mm 176.77"
Q	R 1455 mm 57.28"	R 1455 mm 57.28"
R	5450 mm 214.57"	5450 mm 214.57"

TECHNICAL DATA

ENGINE: DEUTZ (STAGE IIIA / STAGE V)

<i>RTH Model</i>	5.18		5.21 / 5.23 / 5.25 / 6.22 / 6.26	
	Stage IIIA	Stage V	Stage IIIA	Stage V
<i>ENGINE SERIES</i>	TCD 3.6 L4 HT		TCD 3.6 L4	
<i>THERMODYNAMIC CYCLE</i>	Diesel 4 strokes			
<i>ARCHITECTURE</i>	4 in-line cylinders			
<i>VALVES</i>	16 valves			
<i>POWER SUPPLY</i>	Turbocompressed with intercooler			
<i>DISPLACEMENT</i>	3.6 l / 221 cu in			
<i>CYLINDER BORE</i>	98 mm / 3.9 in			
<i>STROKE</i>	120 mm / 4.7 in			
<i>COOLING</i>	Liquid			
<i>INJECTION</i>	Electronics, Common Rail			
<i>CONSUMPTION (*)</i>	210 g/kWh 0.35 lb/hph			
<i>MAXIMUM POWER</i>	55.4 kW / 74 hp @ 2200 rpm		100 kW / 136 hp @ 2200 rpm	
<i>MAXIMUM TORQUE</i>	390 Nm / 288 lb/ft @1300 rpm	405 Nm / 300 lb/ft @1300 rpm	500 Nm / 369 lb/ft @ 1600 rpm	
<i>RATED SPEED AT MINIMUM</i>	850 rpm			

(*) Optimum specific consumption value declared by the engine manufacturer and referring to a diesel fuel with a density of 0.835 kg/dm³ at a temperature of 15°C (59°F).

TRANSMISSION

<i>RTH Model</i>	5.18	5.21 / 5.23 / 5.25 6.22 / 6.26
<i>TYPE</i>	Hydrostatic with electronic control	
<i>MAXIMUM PRESSURE</i>	480 bar	
<i>No. of forward gears</i>	2	
<i>No. of reverse gears</i>	2	
<i>REVERSE GEAR</i>	Electro-hydraulic	
<i>INCHING</i>	Electronically controlled with vehicle in motion	

AXLES

<i>RTH Model</i>	5.18	5.21 / 5.23 / 5.25 6.22 / 6.26
<i>FRONT AXLE</i>	Steering	Steering, with cab-controlled transverse levelling
<i>REAR AXLE</i>	Steering and tilting	
<i>DRIVE AXLES</i>	Front/rear	
<i>WHEEL HUB REDUCERS</i>	Epicyclic	
<i>TYRES</i>	445/65 R19.5	445/65 R22.5

BRAKES

<i>RTH Model</i>	All
<i>TYPE</i>	Multiple disc in oil bath
<i>SERVICE BRAKE</i>	Pedal-operated servo-assisted, action on front and rear wheels
<i>PARKING BRAKE</i>	Hydraulic negative action on front axle

HYDRAULIC SYSTEM

<i>RTH Model</i>	5.18	5.21 / 5.23 / 5.25	6.22 / 6.26
<i>SERVICE PUMP</i>	with variable displacement pistons		
<i>FLOW RATE</i>	95 l/min	112 l/min	130 l/min
<i>PRESSURE</i>	350 bar		
<i>DISPLACEMENT</i>	44 cc	51 cc	60 cc
<i>BOOM AUXILIARY SERVICE LINES</i>	Quick-release couplings with continuous oil function		



ELECTRICAL SYSTEM

<i>RTH Model</i>	All
<i>MASS</i>	negative
<i>BATTERIES</i>	2 x 12 V 190Ah 1200A batteries
<i>ALTERNATOR</i>	28V 80A
<i>START-UP</i>	24V 3.5kW

MASSES

<i>RTH Model</i>	5.18	5.21	5.23	5.25	6.22	6.26
<i>MASS IN THE ORDER OF MOVEMENT</i>	14.400 kg 31,750 lb	15.900 kg 35,050 lb	16.400 kg 36,150 lb	16.600 kg 36,595 lb	19.100 kg 42,110 lb	19.600 kg 43,210 lb
<i>MASS DISTRIBUTION ON FRONT AXLE</i>	6.300 kg 13,900 lb	7.200 kg 15,870 lb	6.900 kg 15,250 lb	7.300 kg 16,095 lb	8.300 kg 18,300 lb	8.550 kg 18,850 lb
<i>MASS DISTRIBUTION ON REAR AXLE</i>	8.100 kg 17,850 lb	8.700 kg 19,180 lb	9.500 kg 20,900 lb	9.300 kg 20,500 lb	10.800 kg 23,810 lb	11.050 kg 24,360 lb

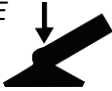
PERFORMANCES

<i>RTH Model</i>	5.18	5.21	5.23	5.25	6.22	6.26
<i>MAXIMUM SPEED *</i>	25km/h 16 mph	40km/h 25 mph				
<i>LIFTING HEIGHT WITH STANDARD FORKS</i>	17,4 m 57,08 ft	20,5 m 67.25 ft	22,9 m 75,13 ft	24,7 m 81,03 ft	22 m 72,18 ft	25,8 m 83,66 ft
<i>GRADEABILITY</i>	51%	43%	42%	41%	34%	33%
<i>MAXIMUM LIFTING CAPACITY *</i>	4.999 kg 11,000 lb				6.000 kg 13,200 lb	
<i>MAXIMUM FORCE EXERTED ON THE GROUND</i> 	12.100 kg 26,675 lb				19.000 kg 41,900 lb	
<i>MAXIMUM FORCE EXERTED ON THE GROUND</i> 	9.000 kg 19,800 lb	9.800 kg 21,600 lb		10.300 kg 22,700 lb	11.500 kg 25,350 lb	
<i>TURRET ROTATION</i>	400° (limited ±200°)	360° continuous				
<i>SWING ANGLE FORKS</i>	135° (+8°; -127°)			133° (+8°; -125°)		
<i>BOOM TYPE</i>	Telescopic with 3 telescopic sections			Telescopic with 4 telescopic sections		

* **To find out the actual load capacity according to the conditions of use of the vehicle, refer to the specific use and maintenance manual of the connected equipment.**

SOUND POWER

<i>RTH Model</i>	5.18	5.21	5.23	5.25	6.22	6.26
<i>REFERENCE STANDARD</i>	2000/14/EC					
<i>GUARANTEED VALUE (dB)</i>	104	106				

SOUND PRESSURE AND VIBRATIONS

<i>RTH Model</i>	5.18	5.21	5.23	5.25	6.22	6.26
<i>SOUND PRESSURE: REFERENCE STANDARD</i>	UNI EN ISO 11201:2010					
<i>SOUND PRESSURE: OPERATOR PERCEIVED VALUE AT 2200 RPM (dB(A))</i>	69.0	72.0 [^]			72.0	73.0
<i>VIBRATIONS: REFERENCE STANDARD</i>	UNI ISO 2631-1:2014 / UNI EN ISO 5349-1:2004 UNI EN 13059:2008					
<i>SEAT VIBRATIONS AT 2200 RPM (m/s²)</i>	0.35	0.49 [^]			0.55	0.59
<i>VIBRATIONS AT THE STEERING WHEEL AT 2200 RPM (m/s²)</i>	0.46	0.57 [^]			0.91	0.94

[^] Values being validated

REFERENCE INFORMATION

Telehandler serial number:

Engine serial number:

Year of production:

Notes:

.....

.....

.....

.....

Dealer name Magni Telescopic Handlers S.r.l.:

Dealer's address:

Attach your business card or enter your dealer information here

Reference person of sales department (Name)

(Telephone)

(E-mail)

Reference person for rental (Name)

(Telephone)

(E-mail)

Service Contact (Name)

(Telephone)

(E-mail)

Contact for spare parts (Name)

(Telephone)

(E-mail)

REGISTER OF CHANGE OF OWNERSHIP

Registration of change of ownership

on _____

The ownership of the vehicle identified in this Register has been transferred to:

Company _____

with headquarters in street/no. _____

Postcode/City/Town _____, Province _____

represented by Mr. _____

It is hereby declared that, at the time of preparation of this document, the technical, dimensional and functional features of the vehicle described in this Register are in line with those indicated at the beginning by the Manufacturer and that changes, if any, have been recorded.

Furthermore, we declare that the transfer has been reported to the relevant Bodies (local INAIL).

The Dealer _____

The buyer _____

Registration of change of ownership

on _____

The ownership of the vehicle identified in this Register has been transferred to:

Company _____

with headquarters in street/no. _____

Postcode/City/Town _____, Province _____

represented by Mr. _____

It is hereby declared that, at the time of preparation of this document, the technical, dimensional and functional features of the vehicle described in this Register are in line with those indicated at the beginning by the Manufacturer and that changes, if any, have been recorded.

Furthermore, we declare that the transfer has been reported to the relevant Bodies (local INAIL).

The Dealer _____

The buyer _____

Registration of change of ownership

on _____

The ownership of the vehicle identified in this Register has been transferred to:

Company _____

with headquarters in street/no. _____

Postcode/City/Town _____, Province _____

represented by Mr. _____

It is hereby declared that, at the time of preparation of this document, the technical, dimensional and functional features of the vehicle described in this Register are in line with those indicated at the beginning by the Manufacturer and that changes, if any, have been recorded.

Furthermore, we declare that the transfer has been reported to the relevant Bodies (local INAIL).

The Dealer _____

The buyer _____

Registration of change of ownership

on _____

The ownership of the vehicle identified in this Register has been transferred to:

Company _____

with headquarters in street/no. _____

Postcode/City/Town _____, Province _____

represented by Mr. _____

It is hereby declared that, at the time of preparation of this document, the technical, dimensional and functional features of the vehicle described in this Register are in line with those indicated at the beginning by the Manufacturer and that changes, if any, have been recorded.

Furthermore, we declare that the transfer has been reported to the relevant Bodies (local INAIL).

The Dealer _____

The buyer _____