

Use and Maintenance Manual

Telescopic handlers

TH 4,5

Deutz stage IIIA

Deutz stage V

Data regarding the manual

Code	100026_TH45-1
Revision	D
Date	03/2024

Reference regulatory framework

This Manual has been drafted in compliance with the main reference standards:

Machinery Directive 2006/42/EC;

Standard Family EN 1459 *“Rough-terrain trucks - Safety requirements and verification”*;

Standard UNI 10653 *“Technical documentation – Quality of product technical documentation”*;

Standard UNI 10893 *“Technical documentation of product – Instructions for use – Articulation and exposition of the content”*.

Original instructions for:

Vehicle model	Trade name	Engine	Emissions regulation	Rated power	Road approval **
TH 4,5.15-D5/A-1	TH 4,5.15	Deutz	Stage IIIA	55.4 kW	-
TH 4,5.15-D5/D-1	TH 4,5.15	Deutz	Stage V	55.4 kW	LH/PN122/EST001A
TH 4,5.15-D7/A-1	TH 4,5.15 P	Deutz	Stage IIIA	74.4 kW	-
TH 4,5.15-D7/D-1	TH 4,5.15 P	Deutz	Stage V	74.4 kW	LH/PN122/EST001
TH 4,5.19-D5/A-1	TH 4,5.19	Deutz	Stage IIIA	55.4 kW	-
TH 4,5.19-D5/D-1	TH 4,5.19	Deutz	Stage V	55.4 kW	LH/PN122/A
TH 4,5.19-D7/A-1	TH 4,5.19 P	Deutz	Stage IIIA	74.4 kW	-
TH 4,5.19-D7/D-1	TH 4,5.19 P	Deutz	Stage V	74.4 kW	LH/PN122

** Certification number only valid for Italy

INDEX

Data regarding the manual	2	Vibration level.....	23
Reference regulatory framework.....	2	VEHICLE'S IDENTIFICATION ELEMENTS	24
PREFACE.....	7	Vehicle plates and marking	24
Manufacturer's details	7	Cab identification plate	24
Important safety information	7	Engine identification plate.....	24
Using the manual	7	Transmission pump identification plate.....	25
People to whom this manual is addressed	8	Service pump identification plate.....	25
Symbols used.....	9	Gear pump identification plate	25
Declaration of initial testing	9	Transmission motor identification plate	25
Delivery of the vehicle.....	9	Axles identification plate	25
Receipt of the vehicle.....	9	TECHNICAL PRODUCT INFORMATION.....	26
Assistance.....	9	Glossary	26
How to request assistance	9	Features of the vehicle	26
Spare parts	9	Optional accessories.....	27
EC Declaration of Conformity.....	10	Interchangeable equipment	27
Warranty	11	General description of the vehicle	28
Recall campaigns for product defects	12	Front/left side.....	28
GENERAL WARNINGS.....	13	Rear/right side.....	29
Hazards and safety instructions	14	Cab interior (plan view)	30
Noise protection.....	14	Cab interior (front view).....	31
Danger of crushing.	14	Safety labels.....	32
Prevention of cuts and crushing.....	14	FEATURES OF THE VEHICLE	37
Danger from hanging load.....	15	Vehicle features and main safety devices	37
Danger of burns.....	15	Vehicle cab.....	37
Danger of battery explosion.....	15	Climbing on to or climbing down from the vehicle	37
Electrocution hazard	15	Door window	38
Works near power lines	16	Rear window.....	39
Accident prevention in case of thunderstorms with		Emergency exit	39
lightning.....	16	Driver's seat	40
Risk of slipping.....	16	Adjustments	40
Risk of falling, tripping.....	16	Armrest.....	41
Penetration of fluids.....	16	Joystick.....	41
Pressurised air and water.....	17	Joystick controls	42
Limiting the ejection of liquids	17	Steering column.....	42
Braking system accumulators.....	17	Light, window wiper, horn selector.....	43
Storage of hazardous liquids	17	Steering wheel.....	43
Information regarding AdBlue®.....	17	Pedals.....	44
Information regarding asbestos	18	Control dashboard	44
USE OF THE VEHICLE	20	Vehicle ignition key.	44
Correct use	20	Safety system limit override key.	44
Before starting the vehicle.....	20	Key for radio control wiring override in aerial work	
Visual inspection	20	platform.....	45
Concomitant work phases.....	21	Multifunctional manipulator;	45
Reasonably foreseeable misuse	21	Service buttons.....	45
Incorrect use	21	Levelling on wheels	45
Safety devices.....	22	Stabiliser controls	46
Safety devices on the vehicle	22	Parking brake engagement button.....	46
Roll-Over Protective Structure (ROPS), Falling Objects		Automatic parking brake	47
Protective Structure (FOPS).....	23	Hazard lights button	47
Sound pressure level	23	Red emergency stop button	47
Sound power level.....	23	Double USB socket	47
		Multiple function display.....	48

Drive page	49	Anchoring points	70
Graduated indicators	49	Tow hook	70
Levelling indicator	49	Quick-fit coupling for the equipment.....	70
Anti-tipping system indicator	50	“1” and “U” couplings	71
List of warning lights and functions that can be selected in the Drive page	51	OPERATING TECHNIQUES	72
Handling mode	56	Before using the vehicle	72
Speed of movements	56	Work area	72
Reset	56	Weather conditions	72
Eco mode.....	56	Climatic conditions of use	73
Radio control connection	56	Road circulation.....	75
Steering modes	56	Parking the vehicle	75
Boom suspension	57	Interchangeable equipment installation	75
Winter mode	57	Equipment confirmation	76
Pick & Carry	57	Removing the equipment.....	77
Stabilizers page	58	Hydraulic shear pin.....	77
Graduated indicators	58	List of compatible accessories.....	78
Self-levelling	58	Approved equipment	78
Limits page	59	Handling of loads.....	79
Limitation of telescopic boom extension	59	Centre of gravity of the load	79
Hydraulic movements speed.....	60	Picking up a load from the ground with fork attachment plate	79
Setting the movement speed limits	60	Taking a load from a height with the vehicle on tyres with fork attachment plate	80
Load page.....	61	Placing a load at a height with the vehicle on tyres.....	81
Flow rate diagram in static view	61	Picking up a cylindrical load without pallet with fork attachment plate.....	81
Flow rate diagram in dynamic view	61	Moving the centre of gravity.....	81
Commands page	62	Visibility	81
Air-conditioning system	62	Traversing over sloping ground.....	82
Auxiliary lighting system	62	INFORMATION REGARDING TRANSPORT	83
Ancillary functions.....	62	Shipping the vehicle	83
Radio control connection	63	Lifting the vehicle	83
Working mode.....	63	Anchoring the vehicle for transportation.....	84
24V electrical output at boom head	63	Towing the vehicle	85
Continuous hydraulic fluid	63	Mechanical brake release	85
Idle speed/engine control	63	Manual positioning of the reverse gear in neutral.....	85
Start & STOP.....	64	MAINTENANCE.....	87
Cooling fan rotation reversal	64	General information	87
Password Pages.....	64	Vehicle in maintenance position	87
System Info page.....	65	Tightening torques	87
Air vents	65	Tyres	88
Service compartments for the vehicle driver	65	Standard inflation pressures	88
Safety keys container	65	<i>Inflation with air</i>	88
Vehicle radio	66	Inflation with nitrogen	89
Reading light	66	Replacing the wheels	89
Sunshade.....	66	Washing.....	90
Radio control battery charger	66	Liquids, lubricants and spare parts.....	91
Radio control housing (Optional).....	67	List of spare parts for routine maintenance.....	92
External elements.....	68	Maintenance Schedule	93
Work and emergency lights	68	Maintenance operations	94
Rear view mirrors.....	68	Safety information	94
Headlights	68	Battery disconnect switch	94
Tail lights (Optional).....	68	Maintenance operations under the telescopic boom..	94
Additional cab work lights.....	69		
Additional work lights on the telescopic boom (Optional)	69		
Shear pin housing for interchangeable equipment	69		

Maintenance operations in areas not accessible from the ground	95	REFERENCE INFORMATION	134
Hydraulic hoses	95	REGISTER OF CHANGE OF OWNERSHIP	136
Differentials oil	95		
Wheel reduction gears oil	96		
Transmission shaft.....	96		
Steering elements	96		
Axles	97		
Transmission belt	97		
Checking the belt tension.....	97		
Replacement	97		
Engine oil	98		
Checking the engine oil level.....	98		
Changing the engine oil	98		
Replacing the lubrication oil cartridge	98		
Fuel prefilter.....	99		
Fuel filter	99		
Bleed the fuel supply system.....	100		
AdBlue® filter.....	100		
Fuel tank.....	101		
Coolant	101		
Bleeding the cooling system.....	102		
Engine radiator	102		
Hydraulic fluid	102		
Hydraulic fluid filter.....	103		
Two-speed reduction gear oil.....	103		
Engine air filter	103		
Cab air filter	104		
Telescopic boom sliding blocks	105		
Telescopic boom pins	105		
Telescopic boom chains	106		
Adjustment.....	107		
Checking for wear.....	107		
Stabilisers	108		
Batteries	108		
Windscreen washer liquid tank	109		
FUSE SECTION	110		
TROUBLESHOOTING.....	118		
Using the emergency hydraulic pump (if any).....	118		
DIAGNOSING PROBLEMS	120		
VEHICLE STORAGE.....	128		
Leaving the vehicle unused for long periods.....	128		
Leaving the vehicle unused for less than 12 months	128		
Leaving the vehicle unused for less than 36 months	128		
Reusing the vehicle.....	128		
Dismantling and disposal of the vehicle	128		
DIMENSIONS	129		
TECHNICAL DATA	130		
Performances	130		
ENGINE: DEUTZ (STAGE IIIA / STAGE V).....	131		
Transmission.....	131		
Hydraulic System.....	131		
Electrical System.....	132		
Braking System	132		
Axles	132		
Tyres	132		
Environmental data	133		

PREFACE

Manufacturer's details

Magni Telescopic Handlers S.r.l.
Via Magellano, 22
41013 Castelfranco Emilia (MO) – ITALY
Tel. +39 059 8031000
Fax. +39 059 8638012
www.magnith.com

Important safety information

Most accidents caused by the use, maintenance and repair of a vehicle are due to failure to observe the most elementary rules of safety and caution. An accident can often be avoided if the potential hazards to which one is exposed are known, and the required precautions are taken. Those working on the vehicle must take the utmost care, have suitable technical skills, knowledge and equipment for carrying out the various operations correctly.

Improper and/or incorrect use, maintenance or repair of these vehicles can lead to serious injury and also death of workers.

Use the vehicles and/or carry out maintenance or repairs on them only after having completely read and understood all the instructions in this use and maintenance Manual.

The precautions and warnings regarding safety are highlighted in this Manual and on the vehicle by means of the informative stickers. Failure to heed these warnings may result in serious injury or even death of the operator or other persons.

Magni Telescopic Handlers S.r.l. may not be able to foresee all the possible circumstances which can constitute a safety hazard. The warnings contained in this Manual or applied on the vehicle may not be considered as all-inclusive. When adopting procedures, equipment or methods not expressly recommended and when using equipment different to that permitted, it is the operator's responsibility to make sure work is carried out in accordance with the main safety and legal standards.

Moreover, it is necessary to ensure that the vehicles are not rendered hazardous by accidental damage or emergency maintenance carried out without authorisation.

Magni Telescopic Handlers S.r.l. reserves the right to make modifications to the vehicles, their accessories, calibration and other information disclosed at any time without prior notification.

Using the manual

This manual must be considered an integral part of the vehicle, and must accompany it throughout its working life from commissioning to final disposal.

Therefore, it must be stored inside the vehicle, in the space provided or where it will be kept safe from premature deterioration, so that it is always readily available for consultation and in the best possible condition.



If lost and/or damaged, contact the Manufacturer directly for replacement documentation, indicating the manual code or vehicle code/model shown on its identification plate.

This manual has been drawn up by the Manufacturer with the aim of providing all the information necessary for the operator to use the vehicle correctly and safely and carry out routine maintenance on it.

This Manual contains all the information necessary for the operator. The operator must use the vehicle for the purposes envisaged and identified in this manual. The information must be read carefully and its contents strictly applied. Failure to comply with this information can lead to risks to the health, safety and welfare of persons and result in damage to property.

The manual reflects the state-of-the-art at the time the product was placed on the market. The Manufacturer reserves the right to make changes, additions or improvements to the Manual, without however resulting in this publication being considered inadequate.

All changes to the documentation are made following a controlled process. The different revisions ensure traceability by associating the manual with the different versions of the product placed on the market.

If the vehicle is fitted with optional accessories, a use and maintenance manual for the following will be provided together with this manual:

- **interchangeable equipment (lifting accessories, fork carriage, platforms, etc.).**
- **special set-ups (elevating cab, electromagnetic braking device, additional heater, etc.)**

The use and maintenance manuals of the interchangeable equipment and special set-ups must be considered as an integral part of the manual; therefore they must be kept safe and consulted using the same methods and with the same care.

People to whom this manual is addressed

This manual is addressed to:

- *operator*: a person trained and instructed with a specific theoretical-practical course for the use of the vehicle and related equipment,
- *general maintenance technician*: a person trained to carry out ordinary maintenance work with basic knowledge of mechanics, electricity and hydraulics,
- *specialised maintenance technician*: a person trained and instructed to carry out ordinary and extraordinary maintenance work with specific in-depth knowledge of mechanics, electricity and hydraulics.

Symbols used

The symbols used in this Manual comply with standard UNI EN ISO 7010:2012.

Danger indications included in this manual are made easily identifiable by a “warning symbol” flanked by one or more “words of warning”; in addition, there is always a message, in written or illustrated form, underneath the symbol, illustrating the danger and techniques for avoiding it.

Parts of the text that are considerably important or specific operating procedures have been highlighted with the use of the following symbols:

NOTICE

BLUE – WITHOUT safety alert symbol

Used to indicate the presence of a potentially dangerous situation which, if not avoided, can cause damage to property.



CAUTION

YELLOW – WITH safety alert symbol

Used to indicate the presence of a potentially dangerous situation which, if not avoided, can cause minor or moderate injury.



WARNING

ORANGE – WITH safety alert symbol

Used to indicate the presence of a potentially dangerous situation which, if not avoided, can cause death or serious injury.



DANGER

RED – WITH safety alert symbol

Used to indicate the presence of an imminently dangerous situation which, if not avoided, can cause death or serious injury.

Declaration of initial testing

Magni Telescopic Handlers S.r.l. declares that each vehicle and interchangeable equipment manufactured in its factories, before being placed on the market, has been subjected to inspections and tests in order to certify its compliance with the EU directives to which it is subject.

Following successful testing, Magni Telescopic Handlers S.r.l. issues a CE certificate for each of its vehicles/interchangeable equipment, which must be kept by the owner of the latter for the purposes of legal obligations.

Delivery of the vehicle

Magni Telescopic Handlers S.r.l. delivers the vehicle in compliance with the relevant construction standards and legislation in force depending on the country of use.

All references to standards are referred to in the CE certificate delivered with the vehicle and this Use and Maintenance Manual.

Receipt of the vehicle

If there are any damage, defects or missing items upon receipt of the vehicle, please contact the Sales Department immediately:

Magni Telescopic Handlers S.r.l.
Via Magellano, 22
41013 Castelfranco Emilia (MO) – ITALY
Tel. +39 059 8031000
Fax. +39 059 8638012
www.magnith.com

Assistance

How to request assistance

For all requests for assistance, the customer must contact Magni Telescopic Handlers S.r.l. After-Sales Service or Sales network directly, indicating the data given on the vehicle identification plate and the type of problem encountered.

Spare parts

For any spare parts, the customer can contact Magni Telescopic Handlers S.r.l. After-Sales Service directly, indicating the vehicle model and its serial no., and order the necessary components and/or devices.

EC Declaration of Conformity

DICHIARAZIONE "CE" DI CONFORMITA'
secondo Direttiva 2006/42/CE, allegato II, parte 1, lettera A

Il sottoscritto Dott. Riccardo Magni, in qualità di Legale Rappresentante della Società,

MAGNI TELESCOPIC HANDLERS S.r.l
Via Magellano 22
41013 Castelfranco Emilia (MO), Italia

quale persona autorizzata a costituire e conservare il Fascicolo Tecnico,

DICHIARA
sotto la propria esclusiva responsabilità,
che la macchina:

Carrello elevatore telescopico

MODELLO: **TH 4,5.15-D7/D-1**

NUMERO DI SERIE: **XXXXXXXX**

ANNO DI FABBRICAZIONE: **XXXX**

è conforme alle disposizioni delle seguenti direttive e leggi:

2006/42/CE	
D.Lgs. 262/2002	
2005/88/CE	
2000/14/CE	procedura applicata secondo l'allegato II, parte 1
Organismo notificato; ECO Certificazioni S.p.A., via Magellano 33, 41018 Faenza (RA) Italy	
Organismo notificato n° 0714	
Potenza netta installata	[kW] 74,4
Livello di potenza acustica misurato L _{WA}	[dB(A)] 104
Livello di potenza acustica garantito	[dB(A)] 106
2014/30/UE	
2014/53/UE	

• e altresì conforme alle seguenti norme armonizzate:

EN 12895:2015+A1:2019 Carrelli industriali - Compatibilità elettromagnetica

MAGNI TELESCOPIC HANDLERS S.r.l
Dott. Riccardo Magni
Legale Rappresentante
Castelfranco Emilia (MO), Italia, XX/XX/XXXX

ce_IT_87710_00

Warranty

Magni Telescopic Handlers s.r.l. ensures that its new Products (vehicles, interchangeable equipment and spare parts), under normal use and operation, shall be free from defects in material or workmanship for a period of twenty-four (24) months or 2000 hours of operation (vehicles and interchangeable equipment), and twelve (12) months, for spare parts. Each such period shall commence on the date on which Magni Telescopic Handlers S.r.l. delivers the Product to the Buyer, if the Buyer is a distributor of Magni Telescopic Handlers S.r.l. and delivers the Product to the End User. Each such period shall commence on the date of delivery of the Product by the distributor to the End User, but never more than six (6) months from the date of delivery of the Product by Magni Telescopic Handlers to the distributor, through the Magni portal channel. Spare parts mounted on or in a Product under warranty repair will acquire the warranty of the Product itself. The above warranties shall be honoured provided that Magni Telescopic Handlers S.r.l. receives written notice of the defect within thirty (30) days of its discovery, and it is stipulated that the product is stored and operated within the nominal limits and normal use and in strict compliance with the Magni Telescopic Handlers operation and maintenance manual, and the defect does not result in any way from the intervention, inactivity or abuse of the purchaser or third parties. If it cannot be established that the conditions and the above are fulfilled, this warranty will not cover the alleged defect.

If requested by Magni Telescopic Handlers, the defective product shall be returned to Magni Telescopic Handlers, or other premises designated by Magni Telescopic Handlers, for inspection. Magni Telescopic Handlers reserves the right to review product maintenance procedures to determine whether the alleged defect is covered by this warranty. Inspection procedures are required on delivery to validate warranty and workmanship.

Under the terms of this warranty, the obligation and liability of Magni Telescopic Handlers are expressly limited - at the sole discretion of Magni Telescopic Handlers S.r.l. - to the repair or replacement with new or reproduced parts or components, in any part, which Magni Telescopic Handlers S.r.l. finds defective in material or manufacture. Spare parts will be supplied to the buyer in accordance with Magni Telescopic Handlers S.r.l.'s current warranty management procedures.

All products replaced under warranty become the property of Magni Telescopic Handlers S.r.l.

Accessories, assemblies and components included in the products, which are not manufactured by Magni Telescopic Handlers, are subject to the warranty of their respective manufacturers.

This warranty shall be deemed null and void if the parts (including worn parts) used or assembled to the product are not original Magni Telescopic Handlers S.r.l. or if the serial numbers have been altered, made illegible or removed with respect to Magni Telescopic Handlers products or if the product has been tampered with without Magni Telescopic Handlers' prior written consent.

MAGNI TELESCOPIC HANDLERS MAKES NO OTHER WARRANTIES, EXPRESSED OR IMPLIED, AND MAKES NO WARRANTIES OF MERCHANTABILITY OR FITNESS FOR ANY PARTICULAR PURPOSE WHATSOEVER.

No employee or representative is authorised to modify this warranty unless such modification is made in writing and signed by an authorised officer of Magni Telescopic Handlers.

This warranty is intended to be continuous for the specified periods. Magni Telescopic Handlers does not accept interruptions and resumptions of such periods ("stop-and-go").

Magni Telescopic Handlers S.r.l.'s obligation under this warranty does not include the items listed below under "This warranty does not cover".

NON-TRANSFERABILITY OF THIS WARRANTY: This warranty is limited to the buyer or, where the purchase is made from a Magni Telescopic Handlers distributor, to the first end-user using the product, and is not assignable or otherwise transferable without the prior written consent of Magni Telescopic Handlers.

THIS WARRANTY DOES NOT COVER:

- normal maintenance, repair, spare or worn parts, including without limitation bearings, seals, couplings, hoses, clutch plates, glass, clutch and brake linings, filters, rope, outer covering, proper sealing of bolts, nuts and fittings, addition or replacement of fluids, filters, vents, belts, nozzles, adjustments of any kind, supplies and services offered, such as hand cleansers, wipes and lubricants, inspections, travel time;
- products sold by any person, company, collaborator or any other third party who is not authorised to distribute the product by Magni Telescopic Handlers;

- damage or defects, or any related costs, resulting from work performed by personnel not authorised to service and repair the product by Magni Telescopic Handlers;
- damage or defects caused by the use of the product by personnel or operators not authorised, instructed or trained in the use of the product;
- damage or defects resulting from inappropriate storage, exposure to external agents, non-use, use in an environment with the presence of chemical or corrosive agents;
- damage or defects caused by using the product in extreme geographical or weather conditions without the prior written consent of Magni Telescopic Handlers;
- damage or defects caused by non-compliance with Magni Telescopic Handlers' campaign bulletins, product safety and service announcements.

THIS WARRANTY EXPRESSLY SUPERSEDES AND EXCLUDES ALL OTHER WARRANTIES, REPRESENTATIONS AND CONDITIONS, EXPRESS OR IMPLIED, AND ALL OTHER LEGAL, CONTRACTUAL, NON-CONTRACTUAL AND COMMON LAW OBLIGATIONS OR LIABILITIES ON THE PART OF MAGNI TELESCOPIC HANDLERS S.R.L., WHICH ARE HEREBY EXPRESSLY EXCLUDED TO THE FULLEST EXTENT PERMITTED BY LAW.

IN THE EVENT OF ANY BREACH OF WARRANTY BY MAGNI TELESCOPIC HANDLERS, ITS LIABILITY SHALL BE LIMITED EXCLUSIVELY TO THE REMEDIES OF REPAIR OR REPLACEMENT OF ANY DEFECTIVE PRODUCT COVERED BY THE WARRANTY. EXCEPT AS OTHERWISE CONTAINED IN THIS WARRANTY, MAGNI TELESCOPIC HANDLERS DISCLAIMS ALL LIABILITY AND SPECIFICALLY EXCLUDES ANY INDIRECT, CONSEQUENTIAL, INCIDENTAL OR ANY OTHER DAMAGES OR LOSSES WHETHER OR NOT ADVISED OF.



Recall campaigns for product defects

Magni Telescopic Handlers S.r.l., only after ascertaining the nature of the defect found, shall agree with its dealers, resellers and authorised workshops on the method and time of intervention (repair, replacement, modification).

Any work carried out without authorisation, communication sent to/received from Magni Telescopic Handlers S.r.l. or in full autonomy, shall invalidate the warranty on the modified/replaced element and on directly related parts that could be affected by poorly performed work.

GENERAL WARNINGS

NOTICE

Read this manual before using the vehicles covered in it



WARNING

Vehicles may only be operated and/or repaired by qualified and properly trained and instructed personnel.



DANGER



It is strictly forbidden to use the vehicle in an enclosed area with an explosive atmosphere or where vapours, gases or dusts are created that could make it potentially explosive (as described above), as this telescopic handler does not comply with ATEX (“ATmosphere EXplosive”) regulations.



DANGER

All uses of the vehicles and operating procedures not described in this manual are prohibited.

It is strictly forbidden to use the vehicles and their applications otherwise than in accordance with this manual and the nature for which they were designed.



WARNING

Check the condition of the vehicle and interchangeable equipment in use on a daily basis before using them: safety devices, oil leaks, condition of service and safety stickers present.

If there are anomalies and/or damage, make the necessary corrections.

- Do not use the vehicles with wet hands and/or shoes, grease or oil on them.
- If the operator is new to the vehicle, he/she must become familiar with it before using and manoeuvring it in an open area to learn its dimensions as well as the controls and their position.

- Use all appropriate precautions when driving the vehicle:
 - verification of the work area;
 - verification of the weather conditions;
 - signal the movement of the vehicle with an acoustic and light signal;
 - always keep a safe distance from people or things.
- Carefully read the Use and Maintenance Manual of the equipment you intend to use with the vehicle in order to know its specific uses and warnings.



DANGER

Do not operate under the influence of medicinal, alcoholic or narcotic substances that may impair the driver's reflexes.



DANGER

Do not smoke or light naked flames under any circumstances whatsoever. Naked flames in contact with fuel, oil or solvents present on the vehicle or necessary for its maintenance can cause injuries, even fatal.

Inhalation of gases produced by a flame or contact with coolant gas can cause injury to the respiratory airways, even fatal.



DANGER



Do not stand or walk near moving operating vehicles.



DANGER



Do not carry passengers on the vehicle and any equipment connected to it.



DANGER

Do not carry passengers on the vehicle and any equipment connected to it.

Hazards and safety instructions

The persons involved in the operational phases on the construction site must become aware of the potential risks present and the safety measures to be followed.

Appropriate accident-prevention clothing and equipment specific to each type of work must be worn.



CAUTION

Keep Personal Protective Equipment (PPE) in good condition.

Accident-prevention clothing and equipment must always be in good condition and the right size to perform the assigned task.

Replace immediately in case of damage or incorrect sizes before starting or continuing operations.



In order to carry out site activities correctly, always wear:

- protective footwear with anti-crush toe cap and anti-puncture sole,
- protective gloves,
- appropriate clothing,
- high visibility clothing,
- protective goggles,
- protective helmet for falling objects.

NOTICE

In view of the several processing steps that can occur, be aware in advance of the activities to be performed in order to have the required equipment when needed.

Noise protection



WARNING



Wear hearing protection devices (headphones or earplugs) to protect yourself from excessive and annoying noise.

Prolonged exposure to loud noises can lead to hearing damage or loss.

Danger of crushing.



DANGER



Pay attention to mobile and/or moving parts to avoid crushing or dragging.

Prevention of cuts and crushing

Support the equipment adequately before carrying out any kind of work on it. Do not rely on hydraulic jacks for supporting the equipment: these may fall if a pipe breaks or in case of involuntary activation.

Do not try to make any adjustment while the vehicle is in motion or with the engine switched on, unless otherwise specified.

Avoid tampering with the electrical system of the vehicle to try starting the engine. This may cause involuntary movements of the equipment.

Keep at a safe distance while operating the equipment using the control levers. Increase the safety distance if there is a possibility of the moving parts making rapid and sudden movements.

If it is necessary to remove the safety devices fitted on the vehicle to carry out maintenance or repairs, always refit these at the end of operations.

Keep limbs away from the moving fan blades. The fast moving blades are comparable to sharp blades, and can cause serious tears.

Keep small objects away from the moving fan blades. The blades may throw off these objects at high speed, making it dangerous for the safety of persons.

Do not use frayed or bent steel cables. Always wear protective gloves while handling steel cables.

If a pin is tapped with great force, it may come out of its seat suddenly. A pin thrown off with force can cause serious injuries to persons in the vicinity. If tapping on a pin, make sure there is no one in the surrounding area.



WARNING

When removing pins, ensure that you have secured the parts in question to prevent them from falling accidentally and causing damage and injury to property and persons.

Danger from hanging load



DANGER



Pay attention to suspended loads, danger of falling material. Do not approach people when using the vehicle; keep a safe distance.

Danger of burns



DANGER



Do not touch the engine or any components directly connected to it during operation. Allow the engine to cool down before carrying out any maintenance. Before disconnecting any component of the hydraulic or pneumatic circuits, make sure all the residual pressure has been discharged from the circuit.

After operation, the engine coolant is hot and under pressure. Contact with hot water or steam leaks can cause severe burns.

Avoid possible injuries caused by hot water jets. Do not remove the radiator cap until the engine has cooled down. To open, unscrew the cap until it stops. Before removing the cap, discharge all of the pressure.

The oil in the engine, gearboxes and hydraulic system heats up during vehicle operation. The engine, rigid and flexible hoses and other components heat up.

Wait for the components to cool down before starting maintenance or repairs.

Avoid these hazards while repairing or carrying out maintenance on the vehicle by discharging the pressure (with the hydraulic levers on the control valves) before disconnecting or repairing hoses and hydraulic parts.

Before restarting the engine make sure that all fittings are tightened correctly.

Look for any leaks with a piece of cardboard; make sure that your hands and body are protected against pressurised fluids. Protect your eyes with a face shield or safety goggles.

If an accident occurs, immediately seek medical attention. Any fluid injected under the skin must be surgically removed within a few hours to avoid infection.

Danger of battery explosion



DANGER



Keep away from battery poles, sparks, open flames and/or cigarettes.

Do not overturn or tilt the battery to prevent acid leakage.

Do not generate sparks when connecting batteries when charging or connecting with other batteries.

Do not charge batteries at extreme temperatures (too hot or cold) or if they are damaged: they may burst.

When servicing batteries, always wear protective gloves and goggles.

Electrocution hazard



DANGER



All maintenance work and/or adjustments to be performed on live parts must only be carried out by qualified and suitably trained personnel.

Works near power lines

In the case of work to be performed in the presence of power lines, check in advance the availability of adequate safe manoeuvring space.



DANGER



When working close to power lines, maintain the distances specified below:

Voltage (kV)	Distance (m)
≤ 1	3
$1 < U_n \leq 30$	3.5
$30 < U_n \leq 132$	5
> 132	7

Source Italian Legislative Decree No. 81/08 Annex IX for ITALY.

For work close to unprotected power lines performed outside Italy, refer to the local regulations.



WARNING

If it is necessary to work close to power lines, organise the work with an operator on the ground who, at a safe distance, can supervise the vehicle's movements and inform the operator in the cab about excessive proximity to power cables.

The vehicle operators must equip themselves with rubber shoes and gloves, cover the vehicle seat with a rubber cover and take care not to touch any part of the chassis with unprotected body parts.



DANGER



In the event of contact of power lines with the vehicle, the operator inside the vehicle must remain inside waiting for the power supply to be interrupted.

Accident prevention in case of thunderstorms with lightning



DANGER



During a thunderstorm with lightning, the operator must move away from the vehicle and keep at a safe distance.

Never try to climb on or get down from the vehicle if lightning strikes in the vicinity. The operator in the cab must stay inside until the thunderstorm and lightning is over.

Risk of slipping



DANGER



During operations carried out on site, the areas around the equipment can contain various kinds of debris and liquids (oil, water, etc.) that can make the ground slippery. Be extremely careful.

Risk of falling, tripping



DANGER



Be extremely careful when climbing up and down the vehicle.

Penetration of fluids



DANGER



Pressurised fluids such as fuel or hydraulic fluid can penetrate the skin or eyes, causing serious injury.

The pressure values in the hydraulic circuit may remain high for a long time even after the vehicle is switched off. If not discharged properly, the pressure can cause violent ejection of oil and objects.

Do not disconnect or dismantle any of the hydraulic components if the pressure has not been discharged correctly, as this can lead to serious accidents.

Refer to the maintenance section of this Manual for the methods for discharging the hydraulic pressure correctly.

Pressurised air and water



DANGER



Pressurised water can cause injury to tissues, especially if accompanied by debris. Compressed air can cause injuries.

If water or compressed air is used for cleaning operations, wear suitable protective equipment, in particular for sensitive organs like the eyes.

NOTICE

The maximum air pressure for cleaning must be less than 2 bar. The maximum water pressure must be less than 3 bar.

Limiting the ejection of liquids



CAUTION

It is necessary to deal with the leakage of liquids during the operations carried out on the vehicle. Provide suitable containers for collecting the liquids before acting on any component of the vehicle containing fluids.

Dispose of the liquids used in compliance with the regulatory standards in force in the country in which the vehicle will be used.

Braking system accumulators



DANGER



Take utmost care while performing maintenance on the pressurised accumulators.

In order to remove the accumulators safely, switch off the vehicle and then pump the brake pedal about 35 to 40 times.

Once this has been done, and wearing appropriate PPE (overalls, goggles, gloves), carefully wrap an absorbent cloth around the accumulator coupling and start gently unscrewing it, allowing the oil to slowly bleed out until it runs dry.

When the pressure has been fully discharged, remove the accumulator and replace it.

Storage of hazardous liquids



DANGER



All fuels, most lubricants and some antifreeze liquids are flammable; handle them with care to avoid fire and potential explosion.



WARNING

Keep flammable products away from persons not competent and authorised to handle them.



WARNING

Under no circumstances should substances of a different type be mixed.



DANGER



Due to the toxicity of the chemicals, avoid contact with skin and eyes by wearing suitable PPE.

Information regarding AdBlue®

AdBlue® is a water-soluble non-flammable, non-toxic, colourless, odourless liquid. It may be referred to as "urea" or "DEF" (Diesel Exhaust Fluid).

If AdBlue® comes in contact with painted surfaces or aluminium, wash the areas concerned immediately with water.



CAUTION

Do not mix AdBlue® with any additive. Mixing additives with AdBlue® can cause serious faults in the system for post-treatment of exhaust gases.

Any impurity present in AdBlue® can cause malfunctioning of the engine and of the exhaust gases post treatment system. Make sure the AdBlue® is free of impurities. Do not reuse the AdBlue extracted from the system.



This sign is positioned near the AdBlue® tank connector.

AdBlue® and high temperatures

The chemical composition of AdBlue® can change if exposed to temperatures exceeding 122°F (50°C), releasing ammonia vapours.



WARNING

Ammonia vapours are highly toxic and corrosive. Ammonia vapours have a pungent smell, and irritate:

The skin;

The airways;

The eyes.

Do not open the AdBlue tank or any part of its supply circuit while the liquid is hot.

Strictly avoid inhaling ammonia vapours or contact with the eyes and skin.

In case of contact with any part of the body, rinse immediately with water for at least 15 minutes and see a doctor immediately.

AdBlue® and low temperatures

AdBlue® freezes at temperatures below 12.2°F (-11°C). In any case, it is possible to use the vehicle below 12.2°F (-11°C). AdBlue® crystals are mainly formed in the lines between the engine and silencer. Wash with water to remove these crystals.

Storage and disposal

To store AdBlue®, use only containers made of one or more of the following materials:

Cr-Ni steel according to standard
DIN EN 10088-1 /2 /3;

Mo-Cr-Ni steel according to standard DIN EN 10088-1 /2 /3;

Polypropylene;

Polyethylene.

Do not use containers made of the following materials:

Aluminium;

Copper;

Copper alloys;

Non-alloy carbon steels;

Galvanised steels.

AdBlue® can corrode these materials and cause severe damage to the exhaust gases post-treatment system.

Dispose of AdBlue® in accordance with the standards in force in the country in which the vehicle is used.

NOTICE

For engines satisfying the Stage V anti-pollution standards, in order to protect the AdBlue® purification system, wait at least 5 minutes after the I.C. engine is switched off, before acting on the main electric circuit to disconnect it.

Information regarding asbestos

Magni Telescopic Handlers S.r.l. products and spare parts are asbestos-free. Using non genuine spare parts can lead to risk of handling products containing asbestos.

Avoid inhaling dusts which may be produced when handling components containing asbestos fibres. Inhaling these dusts can be harmful for health. The non original components which may contain asbestos are the friction elements of the brakes and clutches, linings and types of gaskets. The asbestos used in these components is generally immersed in resin or sealed in another manner. Normal handling is not hazardous as long as suspended dusts are not produced.



DANGER

If dusts containing asbestos are present, the following precautions must be taken:

Do not use compressed air for cleaning;

Avoid brushing materials containing asbestos;

Avoid grinding materials containing asbestos;

Use wet cleaning methods for parts containing asbestos;

Equip the work area with appropriate air extractors;

If there are no other methods for controlling the dusts, wear a suitable respiratory mask;

Avoid areas where asbestos particles may be present in the air.



Declaration of conformity with Article 14 of Regulation (EU) No 517/2014 of the European Parliament and of the Council

We MAGNI TELESCOPIC HANDLERS S.r.l., VAT NUMBER 03353620366, declare under our sole responsibility that when placing on the market pre-charged equipment, which we manufacture in the Union, the hydrofluorocarbons contained in that equipment are accounted for within the quota system referred to in Chapter IV of Regulation (EU) No 517/2014 as:

<input type="checkbox"/>	A. We hold authorisation(s) issued in accordance with Article 18(2) of Regulation (EU) No 517/2014 and registered in the registry referred to in Article 17 of that Regulation, at the time of release for free circulation to use the quota of a producer or importer of hydrofluorocarbons subject to Article 15 of Regulation (EU) No 517/2014 that cover(s) the quantity of hydrofluorocarbons contained in the equipment.
<input type="checkbox"/>	B. The hydrofluorocarbons contained in the equipment have been placed on the market in the Union, subsequently exported and charged into the equipment outside the Union, and the undertaking that placed the hydrofluorocarbons on the market made a declaration stating that the quantity of hydrofluorocarbons has been or will be reported as placed on the market in the Union and that it has not been and will not be reported as direct supply for export in the meaning of Article 15(2)(c) of Regulation (EU) No 517/2014 pursuant to Article 19 of Regulation (EU) No 517/2014 and Section 5C of the Annex to Commission Implementing Regulation (EU) No 1191/2014 (7).
<input checked="" type="checkbox"/>	C. The hydrofluorocarbons charged into the equipment were placed on the market by a producer or importer of hydrofluorocarbons subject to Article 13 of Regulation (EU) No 517/2014.

MAGNI TELESCOPIC HANDLERS
Mr. Riccardo Magni
 LEGAL REPRESENTATIVE

MAGNI TELESCOPIC HANDLERS Srl
 Via Magliano, 22 - 41013 Castelfranco Emilia (MO) - ITALY
 Tel. +39 059 8031000 - Fax +39 059 8638012 - P. IVA/C.F. IT03353620366 - S01: R7V4K1C - Capitale Sociale 1.262.000 Euro I.v.



Castelfranco Emilia
 ITALY
 11/30/2023

Magni Telescopic Handlers Srl
 Via Magliano, 22 - 41013 Castelfranco Emilia (MO) - ITALY
 Tel. +39 059 8031000 - Fax +39 059 8638012 - P. IVA/C.F. IT03353620366 - S01: R7V4K1C - Capitale Sociale 1.262.000 Euro I.v.
 www.magni.com

USE OF THE VEHICLE

Correct use

NOTICE

Read this manual before using the vehicles covered in it.

Be aware of all the dangers and warnings described here.

The telescopic handler is a vehicle designed for lifting material (and people with an aerial work platform) that can cause serious damage to the operator(s) and the environment if not used as intended.

Therefore, this vehicle **MUST** only be used for the purposes given in this use and maintenance manual.

Observance of the use, maintenance and repair instructions in this document are essential parts of the intended use.



WARNING

The vehicle MUST only be used by trained and qualified personnel who are aware of and follow the instructions given in this use and maintenance manual.

In some countries, it is compulsory for personnel using slewing variable-reach trucks to attend courses in order to obtain a licence.

Before starting the vehicle

Visual inspection

To ensure the maximum useful operating life of the vehicle, and maximum efficiency of and in the operating phases, proceed with a thorough visual inspection before every start-up of the vehicle and the working area.

Look around and under the vehicle, checking to make sure there are no loose or missing bolts, no accumulated dirt, leakage of oil, fuel and other liquids, broken or worn parts.

Check the state of the equipment and hydraulic components.

Check the state and wear of the tyres. If necessary, adjust the inflation pressure.

Check the levels of the oil, coolant and fluid.

Check the AdBlue® tank level (if present).

Remove all accumulated dirt and debris. Carry out all the repairs necessary before starting up the vehicle.

Take a view of the work area, check for any obstacles and assess their extent and the best approach to the operational phases.

Clean the windows, headlamp glass and rear-view mirrors.

Adjust the orientation of the rear-view mirrors to best cover the visual area around the vehicle.

Remove dirt residues from the engine, radiator and the various joints on the vehicle (steering hubs, swing jack, telescopic boom hinges, etc.)

Clean and ensure that steps and grab handles in the cab are dry.

Check the integrity and legibility of all safety and information stickers: replace if not in good conditions.

Check for damage or missing parts.

Check the correct functioning of all joints.

Before starting the I.C. engine, check the level of all the fluids: engine oil, transmission oil, hydraulic fluid, coolant, fuel, urea.

Check under the vehicle for oil, fuel or coolant leaks.

Check the tightness of the wheel bolts.

Check the condition of the tyres and the inflation pressure.

Make sure all the hoods are closed and all guards are installed correctly on the vehicle.



WARNING

It is forbidden to start work with the vehicle or equipment not in perfect condition.

Concomitant work phases

In the presence of other operating vehicles in the same work area, call a meeting to organise the operational phases.

Assess the presence of a suitably trained signalman to coordinate manoeuvres in the vicinity of several vehicles.

Ensure that the operators in the cab are familiar with the indications given by the signalman on the ground.

Reasonably foreseeable misuse

During daily work, it can happen that the vehicle may be used incorrectly or the instructions in this manual may not be followed.



CAUTION

Experience has taught us that there may be some indications of reasonably foreseeable misuse of the slewing variable-reach truck.

The various type of slewing variable-reach truck misuse are strictly forbidden by the manufacturer.

Below is a list of reasonably foreseeable, potentially dangerous situations of misuse:

- the accidental loss of control of the vehicle by the operator;
- the behaviour resulting from a lack of concentration or carelessness by the operator, which does not stem from a desire to misuse the vehicle;
- operating the vehicle on sloping ground without following the guidelines described in the relevant section of this manual;
- the instinctive, unforeseeable reaction of an operator in the event of a malfunction, accident or breakdown while using the vehicle;
- the operator using the vehicle with the feeling that the protection devices are only a hindrance to the operations to be carried out;
- the behaviour resulting from the adoption of the "law of least effort" while carrying out a task with the vehicle;
- the behaviour resulting from external pressure on the operator to keep the vehicle in operation under all circumstances, even potentially dangerous ones;

- the predictable behaviour of certain categories of people such as: adolescents, trainees, apprentices, disabled people, etc.;
- operators tempted to use the vehicle for a bet, for competitions, etc.



WARNING

It is absolutely forbidden to carry passengers other than the driver in the vehicle: they may obstruct the view and hinder the driving manoeuvres of the regularly seated operator.



WARNING

It is absolutely forbidden to transport people in the presence of a passenger platform, even if it is regularly coupled and certified.

The platform may only be used when the vehicle is properly stabilised and the parking brake is applied.

Incorrect use



WARNING

It is strictly forbidden to use the vehicles without adequate knowledge of them.



WARNING

It is strictly forbidden to use the vehicle as a ram to demolish structures: Magni Telescopic Handlers are not designed to withstand and support such stresses.



WARNING

It is strictly forbidden to lift material and persons without the use of specific interchangeable equipment: it is forbidden to tie straps directly onto the telescopic boom or quick-fit coupling.



WARNING

It is absolutely forbidden to carry passengers other than the driver in the vehicle: they may obstruct the view and hinder the driving manoeuvres of the regularly seated operator.

Safety devices



WARNING

Before using the vehicle, ensure that all safety devices are visible and working properly.

Should you find any anomalies in the safety devices, stop working until the fault has been repaired (Contact your dealer or Magni Telescopic Handlers S.r.l. Support Service).

Check that the symbols and safety stickers are clearly legible.

For your own safety and that of others, do not disable or alter operation of the safety devices.

- Dead Man's Joystick Button (manoeuvre enabling button)
- Seat belt, driver's seat
- Emergency exit (door side glass and back window in cab)
- Parking brake button (P);
- Hazard lights button
- Emergency hydraulic pump
- Quick-fit coupling shear pin
- Work area Control System
- Load Control System (LMI)
- Fire extinguishers (depending on equipment)

A detailed description of the safety devices listed can be found in the relevant sections of this manual.



WARNING

When using equipment with electrical or hydraulic connections, these must always be connected properly to the vehicle with the respective connectors.

Failure to connect them stops the safety devices from working correctly, with a risk of damage to property and people and a risk of overturning the vehicle.

The main checks for the equipment safety devices are recommended by the manufacturer with time schedules and must be indicated on the Inspection Register attached to this manual or in the manual of the equipment itself.

These checks ensure that the safety devices work correctly.

Safety devices on the vehicle

Below is a list of the main safety devices on the vehicle:

- ROPS-FOPS certified cab
- Emergency light (red beacon on top of the cab)
- Emergency stop button in the cab
- Safety symbols and stickers on the vehicle
- Driver's seat microswitch (operator seated correctly)

Roll-Over Protective Structure (ROPS), Falling Objects Protective Structure (FOPS)

The cab structure is designed, tested and certified (**Level II**) ROPS/FOPS. The certification label is applied in the upper part inside the cab.



WARNING

Any alteration of the structure can weaken and put the operator at risk.

The protection offered by ROPS/FOPS structures will be affected in case of structural damage.

Avoid structural repair or modification of the ROPS/FOPS structure. These operations will make the structure different from the original, and cause invalidation of the certification.

Vibration level

Hands and arms are subjected to an average weighted acceleration level less than 5 m/s².

The entire body is subjected to an average weighted acceleration level less than 1 m/s².

These levels are measured on a standard vehicle. The measuring procedure used is described in detail in the following standards:

ISO 2631-1:2014

UNI EN ISO 5349-1:2004

UNI EN 13059:2008

Sound pressure level

The sound pressure level perceived by the operator inside the cab is less than 80dB. This level was measured on a standard vehicle. The measuring procedure used is described in detail in the following standards:

EN 12053

ISO 11201

Sound power level

The level of acoustic power emitted (guaranteed) is indicated inside the cab for each model according to the applied engine. The measurement was carried out according to Directive 2000/14/EC subsequently modified by Directive 2005/88/EC.

VEHICLE'S IDENTIFICATION ELEMENTS

Vehicle plates and marking

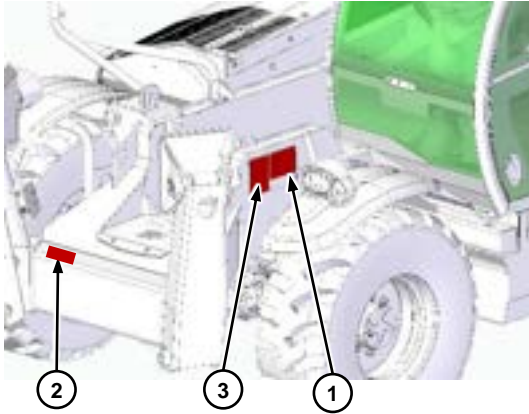

① Manufacturer's plate with vehicle identification data, located under the right front mudguard



② Serial code marking on the upper right-hand portion of the chassis.

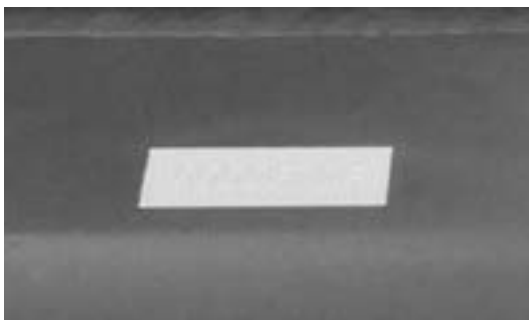

③ Road traffic certification plate, located under the right front mudguard.

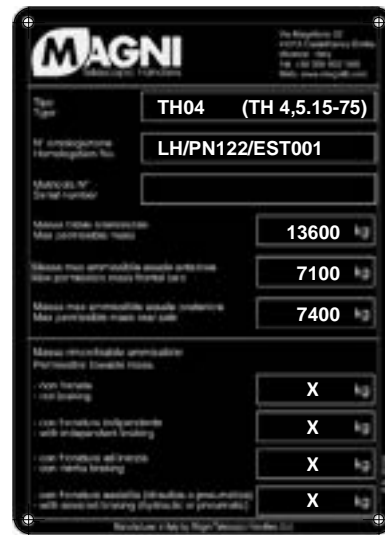

Cab identification plate

The cab identification plate is affixed on the upper crossbar, to the left of the driver.

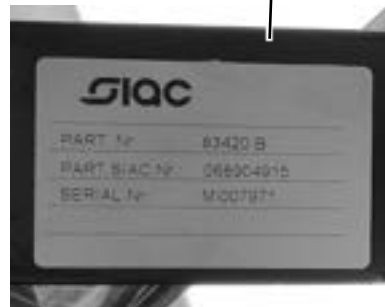
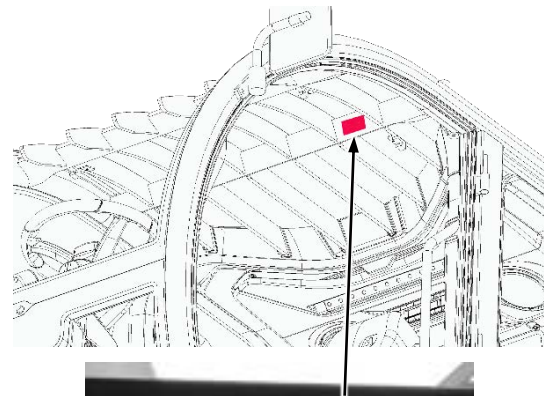

Engine identification plate



The engine identification plate is applied on the upper part of the cover.

Transmission pump identification plate

The transmission pump plate is affixed at the bottom of it, inside the engine compartment, as shown above.



Service pump identification plate

The service pump identification plate is affixed to the pump inside the engine compartment, as shown above.



Gear pump identification plate

The gear pump identification plate is affixed to the pump inside the engine compartment, as shown above.



Transmission motor identification plate

The transmission motor plate is affixed to the motor on the bottom right hand side of the vehicle. To access it, lie down under the vehicle between the two axles near the right front wheel.



Axles identification plate

The axles (front and rear) identification plate is affixed on the top of the differential.



WARNING

Do not remove/damage the plates on the vehicle and its components. The absence of a plate can have an impact on the correct identification of the vehicle/components with consequences in terms of:

- warranty
- certification
- safety

TECHNICAL PRODUCT INFORMATION

Glossary

Front:

area in front of the operator correctly seated in the cab while the vehicle is moving forward.

Rear:

side behind the operator correctly seated in the cab while the vehicle is moving forward.

RH side:

side to the right of the operator correctly seated in the cab while the vehicle is moving forward.

LH side:

side to the left of the operator correctly seated in the cab while the vehicle is moving forward.

Operating machine / vehicle / telehandler:

self-propelled vehicle intended for operation on roads or construction sites equipped with special interchangeable equipment.

Interchangeable equipment:

device which, when assembled with the operating machine, allows the latter a specific functionality.

Features of the vehicle

The telehandler model is equipped with the following standard elements:

- 4-wheel drive and steering of equal size
- Limited slip differential on axle
- Swing lock on rear axle
- Steering alignment indicator
- 2 independent stabilisers with electronic position control on the front axle
- Anti-tilt device with block for dangerous movements
- Easy selection of interchangeable equipment
- Telescopic boom limit switch
- Two-way hydraulic supply at the boom end
- Two-speed travel speed
- Road lights
- Work lights
- Airtight driver's cab with heating, demisting, ventilation and air conditioning, soundproofed and ROPS / FOPS certified
- Front, rear and top window wipers
- Adjustable seat
- Adjustable steering wheel
- Service alarms
- Digital display
- Working area limit control
- Joystick for hydraulic controls
- Hydraulic movements with proportional control valve
- Radio with media player
- Two-speed operation
- Lockable fuel cap

Optional accessories

Below is a list of accessories available for your vehicle model that can be installed at the time of your order or later by contacting your local dealer (if the vehicle is properly preset):

- Cameras with in-cab monitor for perimeter view
- Standard radio control
- Radio control for "aerial platform driving" kit
- Complete tow hook
- Double hydraulic output at the boom head
- Engine coolant heater
- Hydraulic fluid heater
- Complete right spare wheel
- Complete left spare wheel
- Road use (subject to country-specific certification)
- Boom suspension
- Air suspension seat
- Heated seat 24V
- Heated rear view mirrors (24V)
- DAB Radio
- 110V/220 Volt plug at boom end
- Pair of LED headlights on the top-front of the cab
- Pair of LED headlights on the top-rear of the cab
- Pair of LED boom lights
- Nordic climate package
- Oversized stabiliser support bases and associated chassis support
- Hydraulic equipment lock at the telescopic boom end
- Bio hydraulic fluid
- Switching off the batteries from the outside
- Protective grilles for cab windows
- Wheel chocks

NOTICE

The list of optional accessories is subject to change without notice.

Interchangeable equipment

- Fork attachment plate
- Lifting hook
- Lattice-encased boom with lifting hook
- Hydraulic winch
- Hydraulic winch on lattice/encased support
- Aerial work platform for passenger transport (fixed/extendable/rotating)
- Bucket for concrete
- Bucket for light material
- Debris bucket
- Grapple bucket
- Wheel handling gripper
- Rib-laying pliers
- Rotary blade trimmer

NOTICE

The list of interchangeable equipment is subject to change without notice.



CAUTION

All interchangeable equipment not manufactured by Magni Telescopic Handlers S.r.l., in order to be connected to its vehicles, must mandatorily have test clearance and approval from Magni Telescopic Handlers S.r.l..



WARNING

The use of unauthorised equipment by Magni Telescopic Handlers S.r.l. entails full liability on the part of the operator in terms of damage to property and injury to persons.

General description of the vehicle

Front/left side

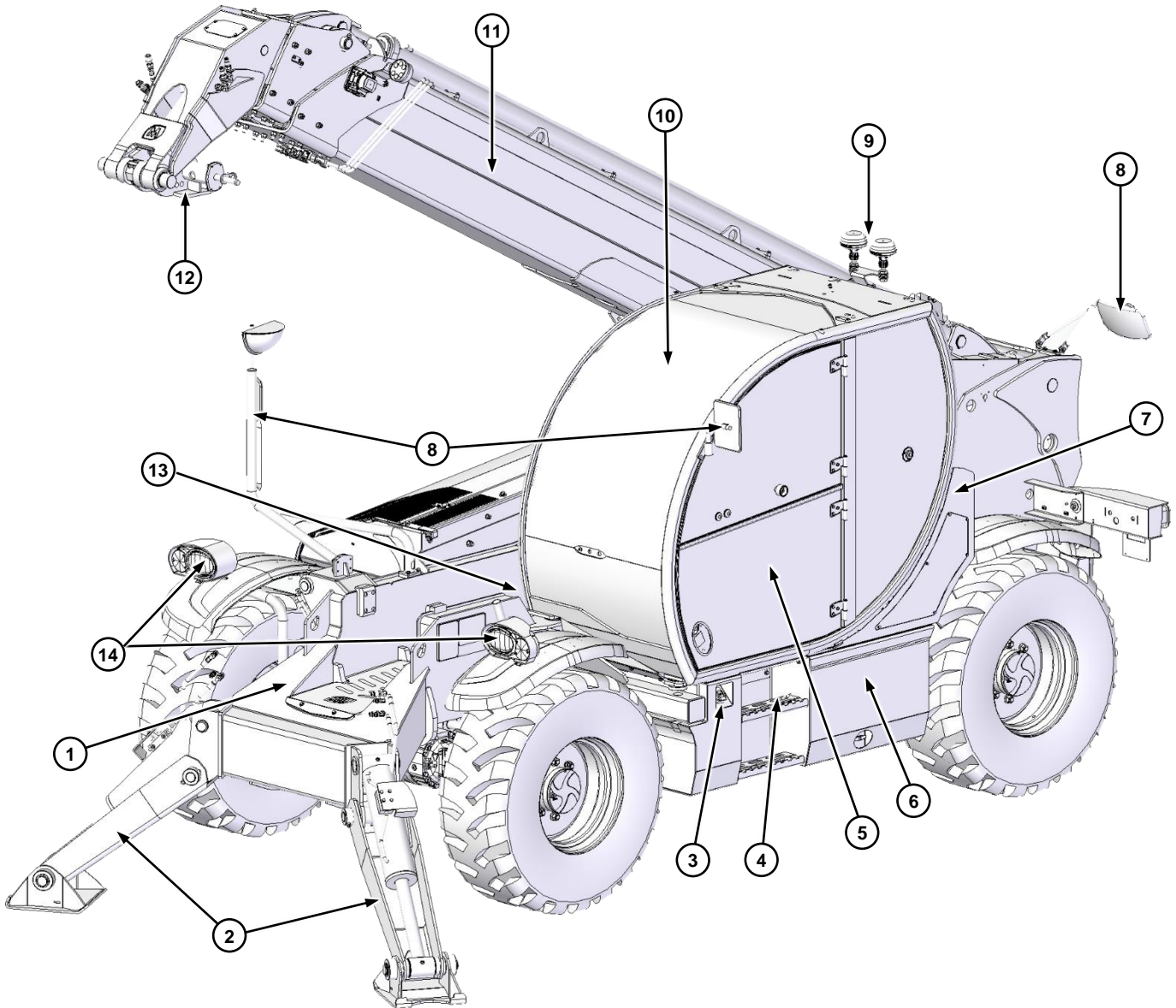

1	Chassis	2	Front stabilisers
3	Diesel tank	4	Cab access ladder
5	Cab access door	6	Electrical system technical compartment, slewing variable-reach truck and/or AdBlue tank
7	Electrical /hydraulic system technical compartment / cab air filter	8	Rear view mirrors
9	Manoeuvre/alarm signal lights	10	Driving and manoeuvring cab
11	Telescopic boom	12	Interchangeable equipment quick-fit coupling
13	Battery compartment	14	Slewing variable-reach truck front lighting devices

Rear/right side

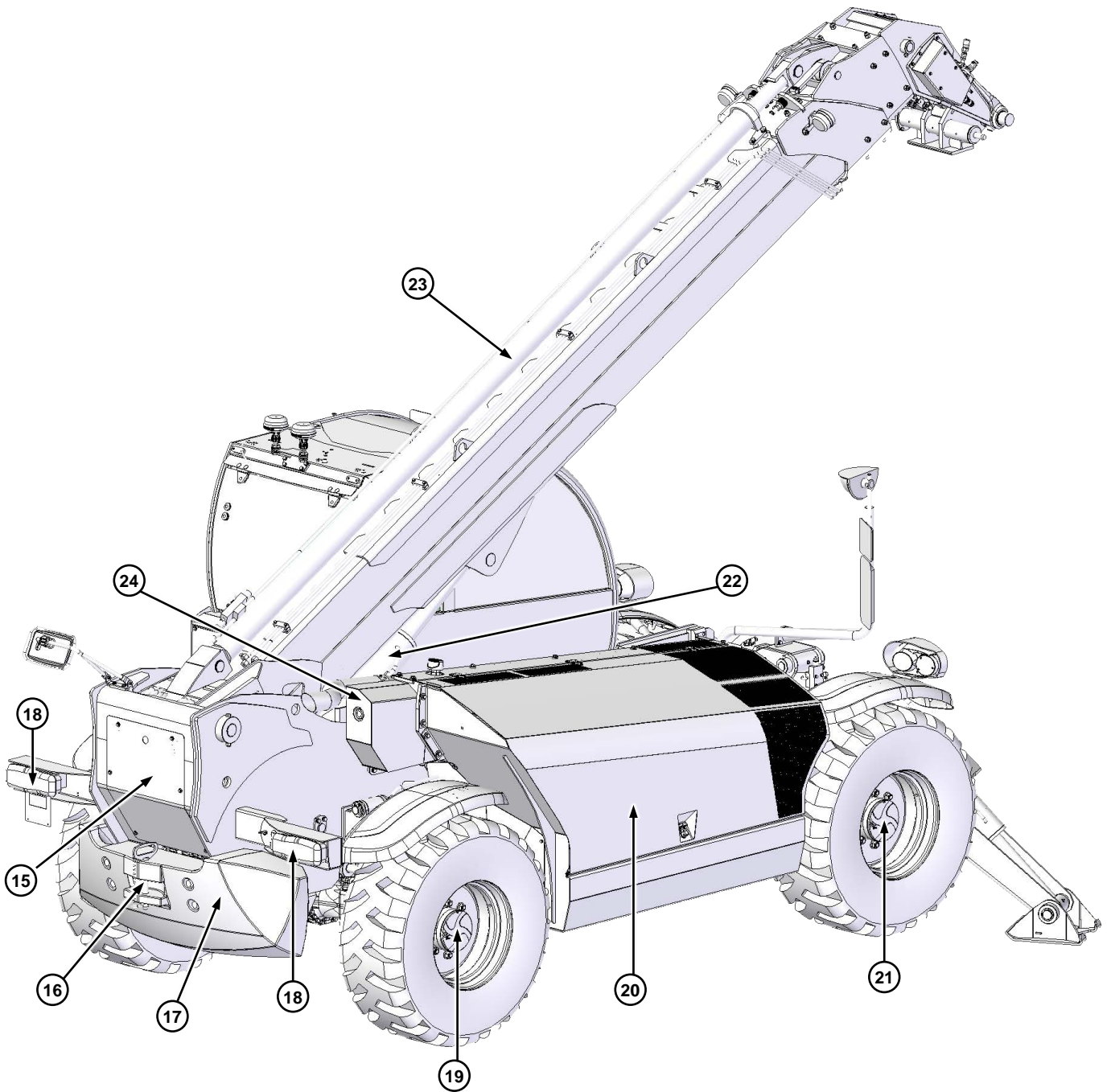

15	Hydraulic hose compartment / Emergency pump (only for D5/A-D engines)	16	Tow hook
17	Counterweight	18	Slewing variable-reach truck rear lighting devices
19	Rear axle	20	Engine compartment
21	Front axle	22	Boom lifting jack
23	Boom extension jack	24	Hydraulic service oil tank

Cab interior (plan view)

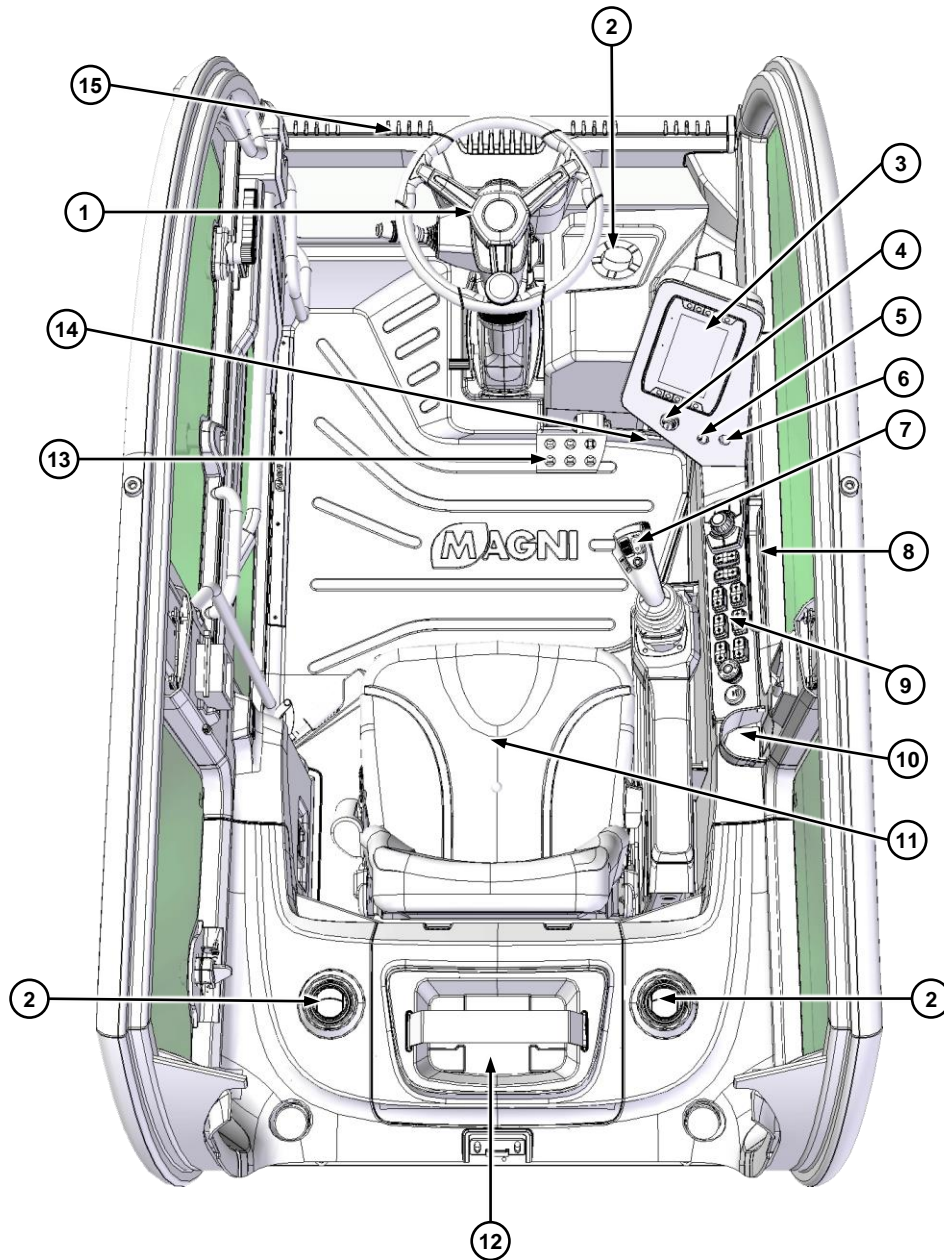

1	Steering wheel	2	Air vents
3	Multiple function display	4	Ignition key
5	Anti-tilt limiter override key	6	Wired radio override key on aerial work platform
7	Right joystick	8	Document/device pocket
9	Control dashboard	10	Beverage holder
11	Seat with headrest	12	Location for radio control when not used
13	Brake pedal	14	Accelerator pedal
15	Air blower for the windscreen		

Cab interior (front view)

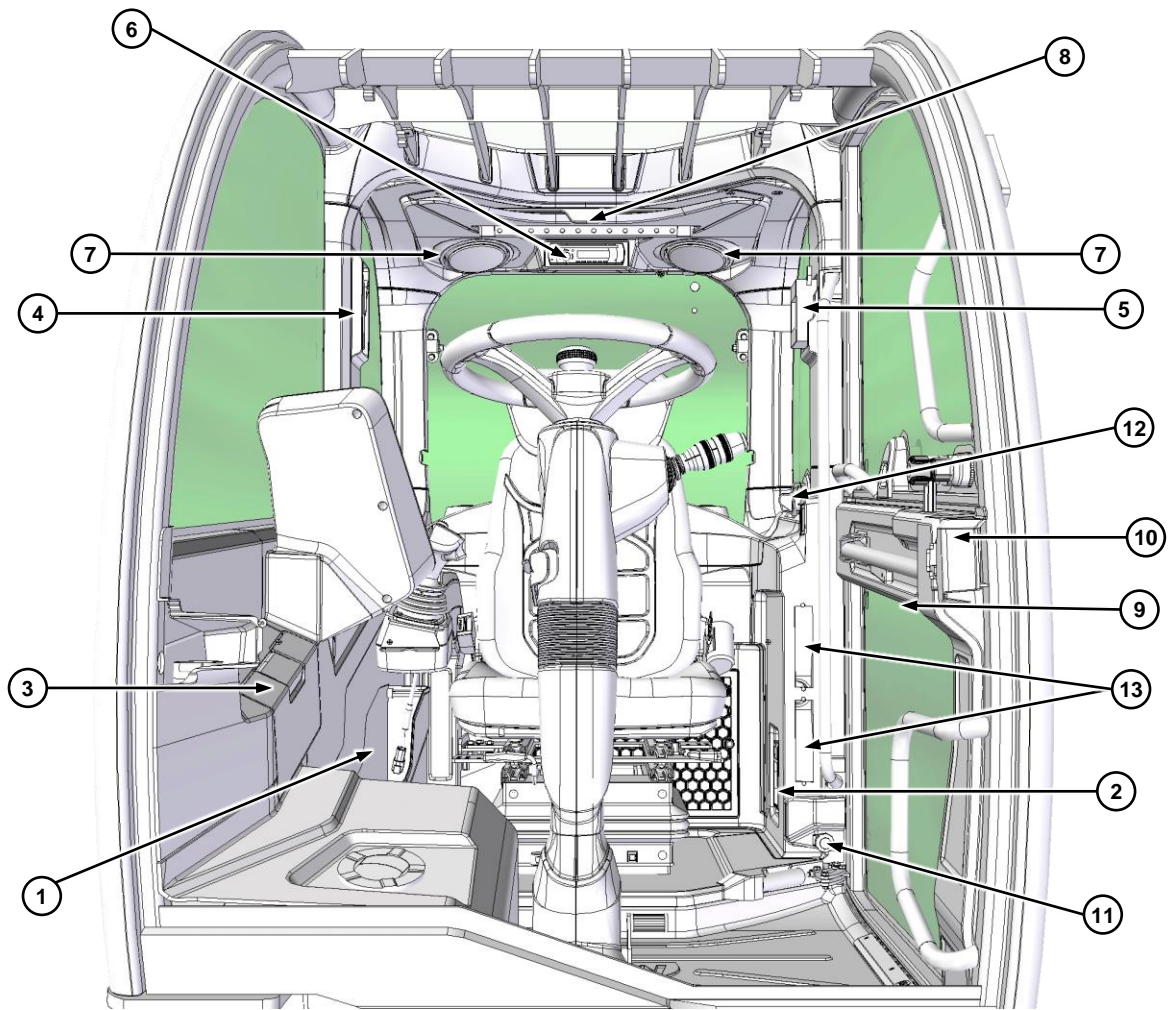

1	Document pocket	2	Battery charger housing for radio control
3	Fuse compartment and operating system USB	4	Rear window breaker hammer seat for emergency exit
5	Emergency key seat with safety glass breaker hammer	6	Vehicle radio
7	Loudspeakers	8	Sunshade
9	Hatch opening lever	10	Door upper portion opening lever
11	Open door lock release knob, from the ground	12	Open door lock release knob, from the cab
13	Air vents		

Safety labels

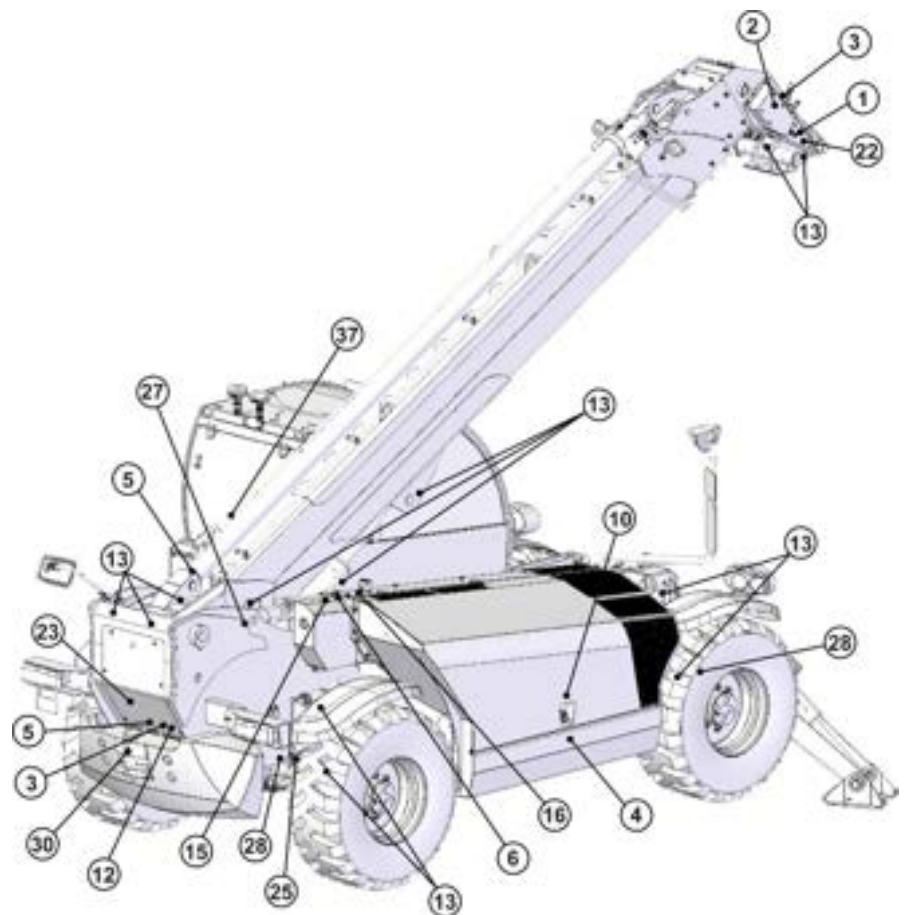
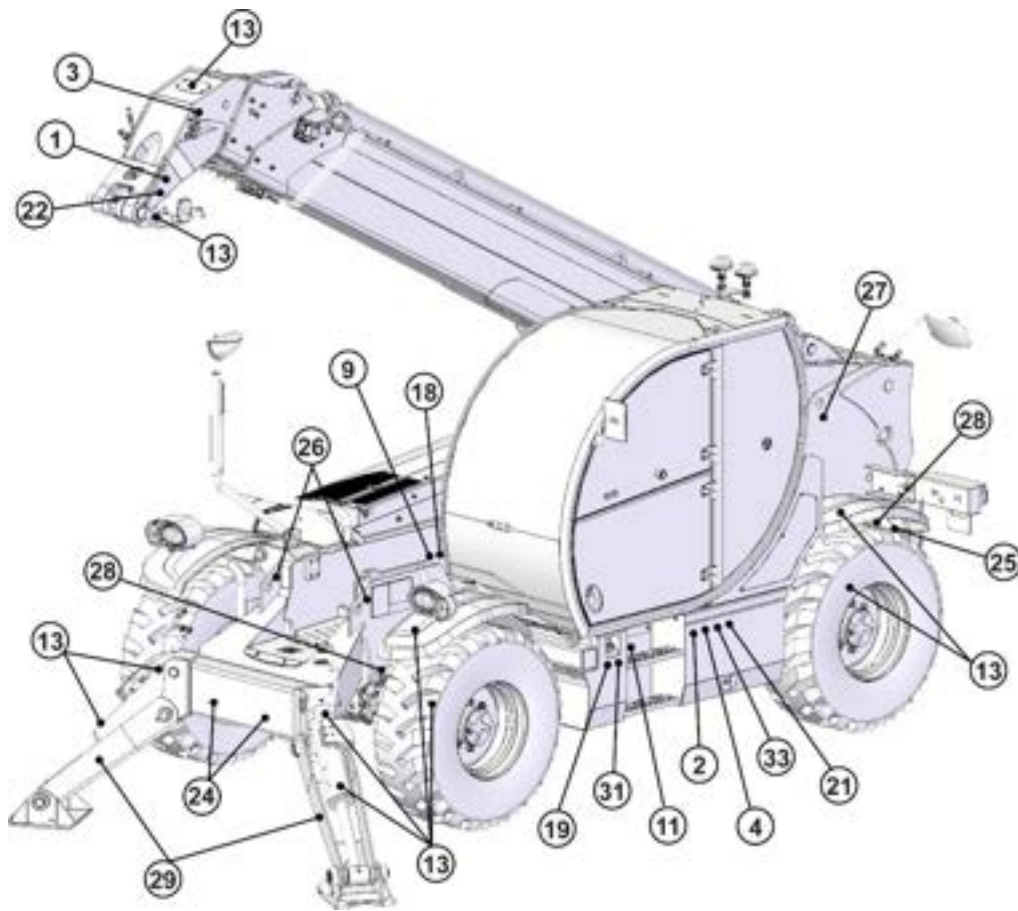

Engine compartment

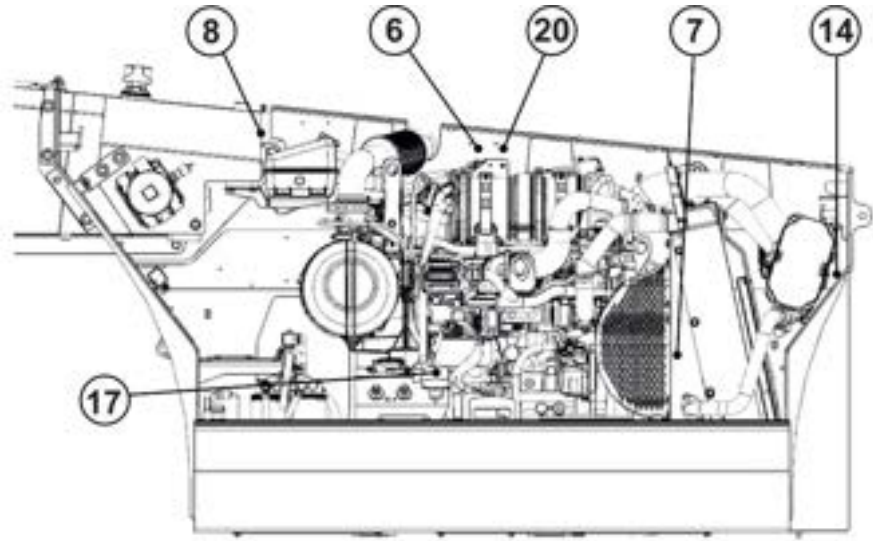



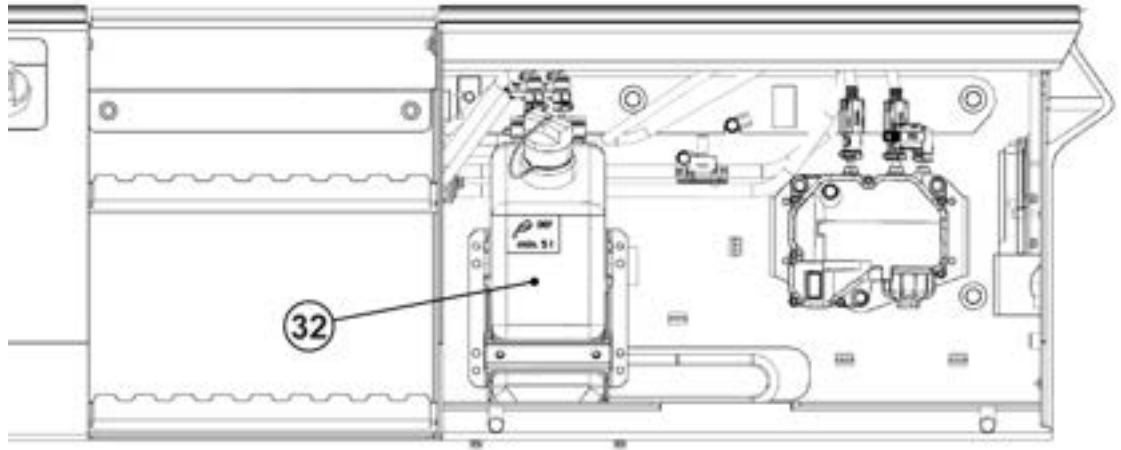



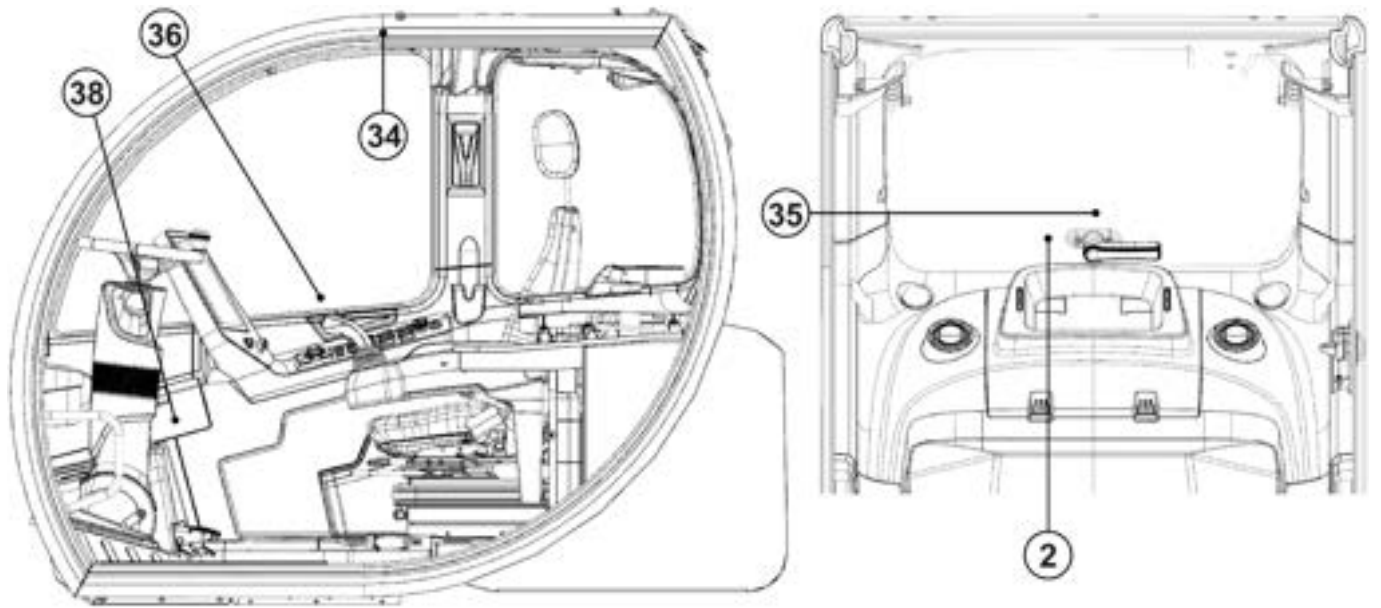





Service compartment



Cab



<i>Ref.</i>	<i>Sticker</i>	<i>Code MAGNI</i>	<i>Description</i>
1		90066	Suspended load warning sticker
2		91579	Electric voltage warning sticker
3		91580	High pressure fluid warning sticker
4		91582	Crushing hands warning sticker
5		91645	Pressure accumulator warning sticker (see manual)
6		91687	Hot surface warning sticker
7		91689	Cooling fan warning sticker
8		92514	Coolant cap warning sticker
9		93473	Multiple danger warning sticker
10		93469	Engine multiple danger/warning sticker (see manual)
11		91591	Multiple ladder warning sticker
12		91685	Manual emergency pump information sticker (only for D5/A-D engines)
13		03439	Grease nipple information sticker

Ref.	Sticker	Code MAGNI	Description
14		91698	Air filter information sticker
15		91694	Hydraulic fluid level information sticker
16		92499	Hydraulic fluid filler cap information sticker
17		91592	Battery disconnection information sticker
18		93471	Information sticker/no open flame in battery compartment
19		91693	Diesel filler cap information sticker
20		92515	"Wear headphones" information sticker
21		92504	"Do not set fire" sticker
22		91604	No climbing on or standing under the interchangeable equipment sticker
23		93474	Danger/information sticker "Do not use high-pressure cleaner on boom pipes"
24		91696	Attachment point information sticker
25		91657	Attachment and tow point information sticker
26		91661	Lifting and tow point information sticker
27		91695	Lifting point information sticker

Ref.	Sticker	Code MAGNI	Description
28		95090	Information sticker about tyre pressure, nut tightening and under-wheel load (see manual)
29		91651	Information sticker about load under stabiliser (see manual)
30		93479	Information sticker about maximum weight that can be towed by the vehicle
31		43221	Information sticker ULTRA LOW SULFUR DIESEL FUEL ONLY (for Stage V engines only)
32		43141	Sticker on AdBlue / DEF ONLY tank (only for D/D engines [Stage V])
33		91703	AdBlue filler cap information sticker (only for D/D engines [Stage V])
34		11071	Sticker for FOPS - ROPS certified cab
35		70784	Emergency exit sign sticker on rear window
36		93476	Cab control information sticker (only present on vehicles for non-US markets)
		93477	Cab control information sticker (only present on vehicles for the US market)
37		39644	LWA 104 dB sticker (only for D5/A-D engines)
		27038	LWA 106 dB sticker (only for D7/A-D engines)
38		94431	Sticker with key of fuses and relays in the technical compartment inside the cab

NOTICE

To request commercial stickers (e.g. stickers depicting logos, vehicle models, etc.) please take note of the relevant codes and refer to the Magni Telescopic Handlers Spare Parts Department.

FEATURES OF THE VEHICLE

Vehicle features and main safety devices

The telescopic handler consists of the following main components:

- Chassis made of two steel sheets and reinforcing crossbars made of high-strength alloy steel.
- Two hydraulically tilting stabilisers positioned at the front end of the chassis
- Oscillating levelling steering front axle;
- Oscillating swinging steering rear axle;
- Right compartment of the slewing variable-reach truck for diesel engine, cooling system and engine equipment.
- Left compartment of the slewing variable-reach truck for diesel tank, hydraulic fluid tank, urea tank (for models equipped with Stage V emission-compliant engines), electrical compartment/vehicle control units.
- Left side vehicle compartment (behind cab) for electrical system (ECU).
- Batteries located in the centre of the chassis.
- Hydrostatic transmission. Hydrostatic pump located on the engine power take-off and hydraulic motor connected to the front axle gearbox (connection cardan shaft from front axle to rear axle, 4WD).
- Telescopic boom pivoted at the rear of the chassis and raised and extended by means of double-acting hydraulic jacks and transmission of movement to the extensions with chains (for models equipped with them). At the end of the main boom there is a mechanical device (quick-fit coupling for interchangeable equipment) that can be moved by means of hydraulic jacks for swinging.
- Cab complete with all controls for driving/moving the handler, electrical/electronic devices, HVAC system (where present), heating/cooling system, adjustable seat and steering column, vehicle radio, FOPS-ROPS certified safety cell according to EN 1459 requirements.
- Street lighting and emergency signalling devices.



WARNING

Before using the vehicle, ensure that all safety devices are visible and working properly. Should you find any anomalies in the safety devices, stop working until the fault has been repaired (Contact your dealer or Magni Telescopic Handlers Support Service).

Check that the symbols and safety stickers are clearly legible. For your own safety and that of others, do not disable or alter operation of the safety devices.

Vehicle cab

The cab structure is designed, tested and certified (Level II) ROPS/FOPS.

APPROVED
FOPS - ISO 3449
ROPS - ISO 3471
Level II

Climbing on to or climbing down from the vehicle



Access to the inside of the cab after opening the door by means of the lock-protected handle with key, located in the lower portion of the door, pulling it outwards.

NOTICE

Always use the steps and handles on the slewing variable-reach truck frame and cab to climb on to or down from the vehicle.

Before climbing on to or climbing down from the cab, clean all steps and handles thoroughly. Damaged steps or handles must be repaired immediately.

Do not climb on or down from the vehicle with your back to it.

Always use three gripping points when climbing up or down: two hands gripping the handles and one foot on a step, or two feet on the steps and one hand gripping the handle.

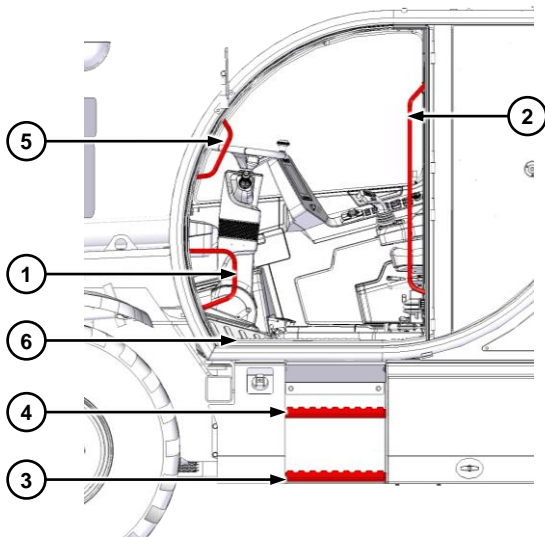

To get in the cab correctly, follow the sequence below:

- grasp the two handles ① and ② located inside the cab,
- go on the steps ③ ④,
- with your left hand grasp the handle ⑤, always keeping your grip on the handle ② with your right hand,
- enter the cab by crossing the threshold ⑥.

To open the door from inside the cab, press the lever on the handrail as shown below, then push the door outwards.

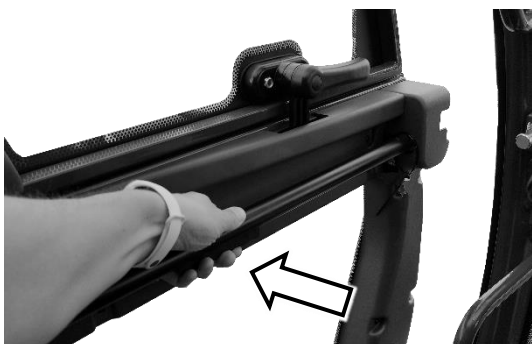

To get out of the cab correctly, follow the sequence below:

- grasp the two handles ⑤ and ② located inside the cab,
- cross the threshold ⑥ of the cab,
- get off the steps ④ ③,
- with your left hand grasp the handle ①, always keeping your right hand on the handle ②.



WARNING

Do not climb on or down when the vehicle is in motion.

Do not climb on or down from the vehicle carrying tools or other objects. Load the tools required before climbing on the vehicle. Unload the tools from the vehicle using a rope to lower these to the ground.



CAUTION

Do not use any of the vehicle's control devices (joystick or steering wheel) as a handhold for getting in or out of the cab: these are not designed for such purpose and could be damaged, even causing the operator to fall.

Door window

To open the upper part of the cab door, act on the "L" lever by turning it upwards. Then, once released, push the half-door, accompanying it as far as it will go to the lock on the rear window.

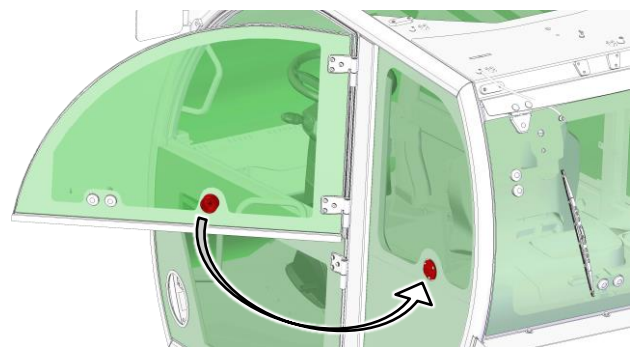

To unlock the half door, turn the knob on the left rear window behind the driver's seat.

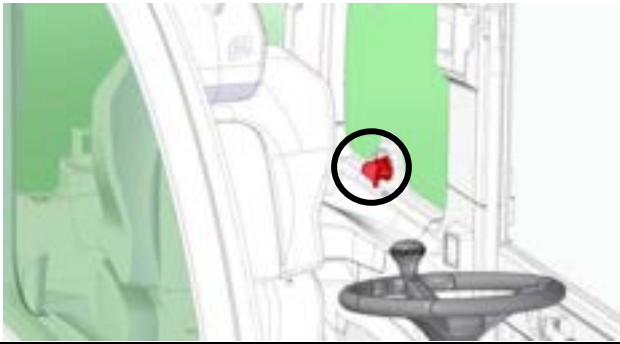

The procedure for unlocking the door window or the entire door (when the window is fixed) can also be performed from outside the vehicle, by turning the knob located at the base of the vertical cab cross member to the left of the driver's seat.



Rear window

To open the rear window, act on the handle at its base by turning it to the left; the rear window opens automatically by means of gas springs.

To close it, grasp the handle by pulling it towards the inside of the cab and lock it by turning it to the right.



Emergency exit

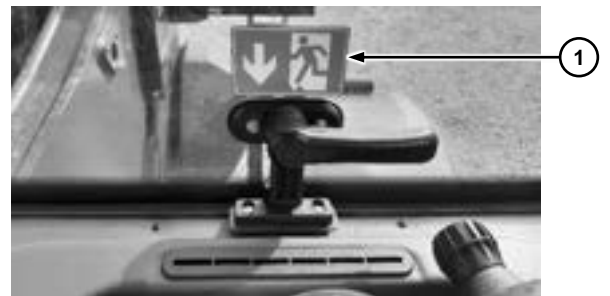

The rear window also serves as an **emergency exit**, as recalled by a special sticker ①. To open it, follow the procedure described above. If it is not possible to exit through the rear window, there is a **RED hammer** on the right door jamb of the cab; this must be used (in the event of an emergency) to break the glass of the cab to facilitate the driver's exit.

NOTICE

Contact your dealer to have the glass replaced.

Driver's seat**NOTICE**

The vehicle's driver's seat not only accommodates the driver of the vehicle in the most comfortable way possible thanks to the adjustment possibilities listed below, it also has the function to enable manoeuvre of the vehicle itself both in terms of translation and general movement when handling loads with a telescopic boom: incorrect seating, detected by presence sensors, inhibits all movements by signalling the error on the multiple function display.

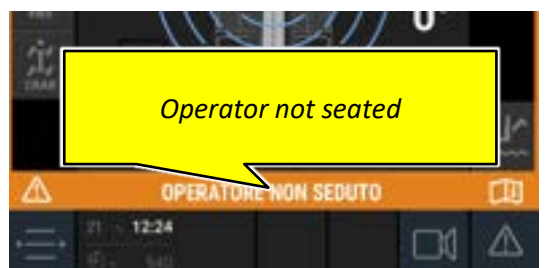
**Adjustments**

- 1- lever for longitudinal adjustment of the entire seat block: act on the appropriate lever to release the translation of the entire seat to and from the driving pedals; once the correct position has been found, release the lever;
- 2- safety belt with retractor: always fasten the safety belt before starting any operation with the vehicle.

**CAUTION**

Always check the fabric of the safety belt, the buckle and winder, every time before using the vehicle.

Replace the seat belt or components found to be worn or damaged.

- 3- backrest inclination adjustment lever: lift the lever to unlock the backrest and adjust its inclination; once the correct position has been found, release the lever; the backrest also provides a folded position above the seat to give access to the rear portion of the cab

- 4- lumbar cushion adjustment knob: use the knob to adjust the depth of the lumbar portion of the backrest;
- 5- seatbelt lock: once the seatbelt is fastened, press the red button on the top to release it;
- 6- longitudinal seat adjustment lever: act on the lever to adjust the distance of the seat surface from the backrest; once the correct position has been found, release the lever;
- 7- armrest and peripheral distance adjustment lever; act on the lever to adjust the distance of the armrests and joysticks from the seat/backrest; once the correct position has been found, release the lever;
- 8- seat tilt adjustment lever: pressed with the seat unloaded, raises the front part of the seat; pressed with the operator regularly seated, unlocks the position; release the lever to the desired tilt size.
- 9- pneumatic seat suspension adjustment

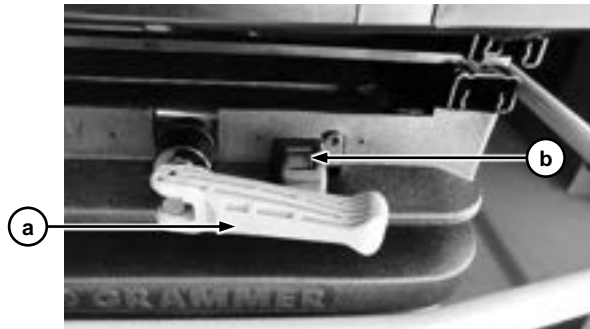

Act on the lever **a**, turning it, to load or unload the pressure on the spring until the indicator **b** shows the value of the driver's weight: it is advisable to adjust the air spring when the seat is unloaded to make the operation easier.

Armrest

Next to the seat on the right-hand side is an armrest and corresponding joystick control for the vehicle's hydraulic functions.

This can be raised next to the seat backrest to facilitate cab maintenance operations.

Joystick

The "TH" vehicles are equipped with a joystick in the cab, near the driver's seat armrest. The joystick controls the main hydraulic movements of the vehicle.

CAUTION

To impart commands using the joysticks, keep the confirmation button on the joysticks and indicated below pressed.

Not pressing the confirmation button prevents accidental movements of the vehicle.

The joystick commands are inhibited if the operator is not seated correctly in his/her seat.

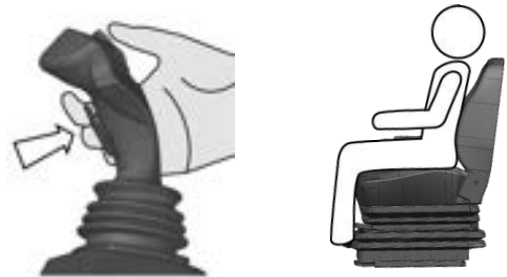

The anomalies described above are shown by means of visual signals on the multiple function display next to the seat.

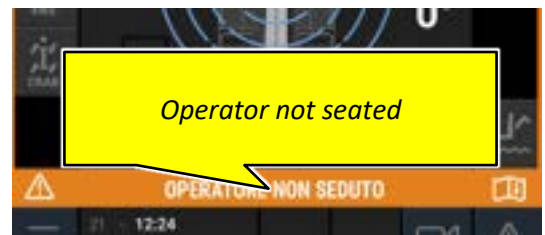
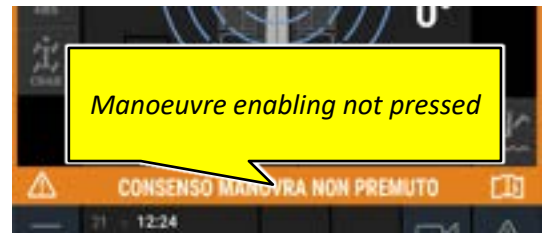

Joystick controls

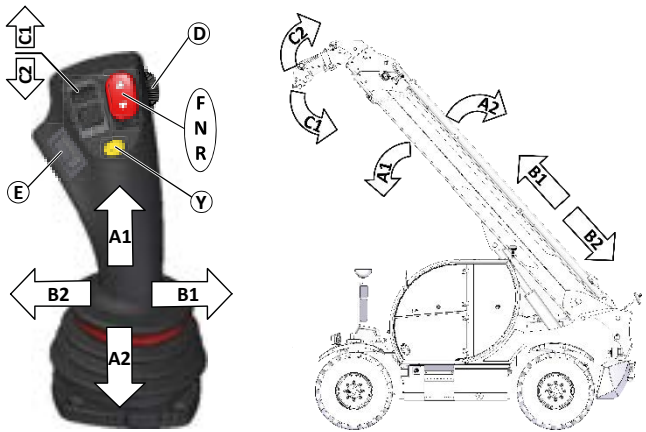

FNR: the red-coloured rocker switch on the top of the joystick activates the vehicle's drive converter:

- at the centre the transmission is in NEUTRAL,
- when pushed forwards the forward movement transmission is activated,
- pressing reverse activates the reverse gear at the same time as the external warning buzzer, reversing lights and camera video (when present) on the control display.

A1: moving the joystick forward lowers the telescopic boom;

A2: moving the joystick backwards lifts the telescopic boom;

B1: moving the joystick to the right forwards extends the telescopic boom;

B2: moving the joystick to the left retracts the telescopic boom;

C1: rotating the roller retracts the swing jack by rotating the equipment downwards;

C2: rotating the roller backwards extends the swing jack by rotating the equipment upwards;

D: moving the roller, the standard hydraulic outlets at the boom head are controlled, which enable specific functions of the equipment, mounted if pre-set. Please refer to the user manual of the currently coupled equipment.

E: the button controls the optional additional hydraulic outlets at the head of the telescopic boom. Please refer to the specific user manual of the currently coupled equipment.

Y: the yellow button, pressed together with the movement of roller **D**, enables the optional hydraulic outlets at the head of the telescopic boom.

Steering column

The steering column is designed to offer various adjustment possibilities, its position can be adjusted in inclination and depth. The correct position of the steering wheel depends on individual preferences:

It must be possible to reach the steering wheel without detaching the shoulders or back from the backrest;

The arms must be bent at right angles when gripping the steering wheel;

The joysticks must not obstruct rotation of the steering wheel while driving, in any manner whatsoever;

The position of the steering wheel must not obstruct the movements of the joysticks, in any manner whatsoever.

To adjust the inclination of the lower part of the steering column, while correctly seated in the driver's seat, press the pedal on the left of the base, shown in the photo, and pull the steering wheel towards you; once you have found the correct position, release the pedal.

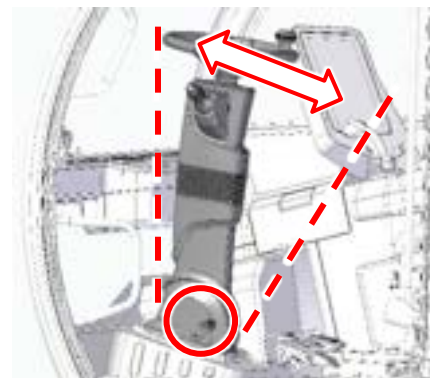

To adjust the inclination of the upper part of the column and the telescopic depth of the steering wheel, use the levers on the right-hand side of the steering wheel.

Pull up the release lever ① to unlock the depth of the steering wheel in relation to the column; once the correct fit has been found, release the lever.

Turn the lever ② outwards to adjust the angle of the steering wheel in relation to the base column; find the right fit and reposition the lever.

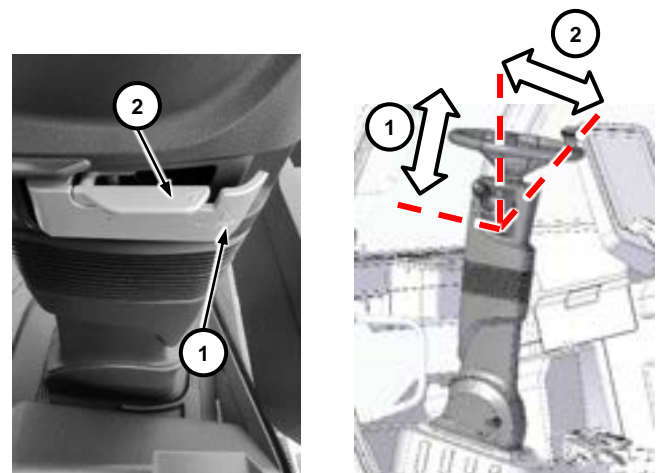

Light, window wiper, horn selector.



The lever on the left of the steering wheel controls the direction indicators, work lights switch and windscreen wipers.

Direction indicators

To activate the direction indicators:

right side: push the lever forwards and upwards,
left side: pull the lever backwards and downwards.

The direction indicators are deactivated when the lever is in the central position.

Lights switch

To activate the lights, rotate the first ring nut to the left:

O: turned off,

: road lights on,

: low beam light on.

To activate the low beams :

move the lever forward for continuous activation,
apply slight traction towards the steering wheel to activate the high beam headlights. The lever will return immediately to the neutral position when released.

Horn

To use the horn, press the button on the tip of the lever.

Do not use the horn in densely populated spaces or where expressly banned by means of signs.

NOTICE

The horn emits a short warning if connected with a radio control (optional).

Steering wheel



Use the steering wheel to guide the movement of the vehicle. A knob is provided to drive with one hand, keeping the other free for other controls.

NOTICE

Do not use the knob for driving on public roads. In these situations, keep both hands on the steering wheel to have better control of the vehicle.

There are three steering modes:

- two-wheel steering: on front axle
- four-wheel steering with concurrent axles for minimum steering range
- four parallel-axle "crab" steering wheels for lateral movement

The steering mode can be changed from the multiple function display on the "Drive" page and under the following conditions:

vehicle stopped;
wheels of both axles aligned validated by the warning lights.

Please refer to the "Steering Mode" section.

Windscreen Wipers/Washers

The vehicle is equipped with three windscreen wipers; their activation occurs in series and is controlled by the right ring nut closest to the column.

Turning it backwards (towards the driver's seat) controls:

O: all windscreen wipers deactivated;

first position: the front window wiper;

second position: front window wiper and top window wiper;

third position: front window wiper, top window wiper and rear window wiper.

To activate the water jet for cleaning the vehicle windows, from the condition of all window wipers off, turn the ring nut forwards (towards the front window): this activates the simultaneous jet on all three windows with automatic activation of the brushes, which will work for a limited time.

Pedals

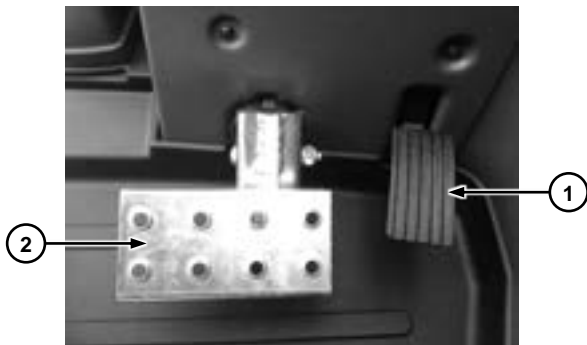

Accelerator pedal

Press the accelerator pedal ① to increase the I.C. engine speed.

Release the accelerator pedal ① to decrease the I.C. engine speed.

Brake pedal (inching)

Press the brake pedal ② to slow down and/or stop the vehicle

In the first 20 mm of travel, the service brake pedal functions as an *inching* pedal similar to the operation of a clutch, allowing the simultaneous depressing of the accelerator pedal to increase engine revs even at minimal speeds.

This increase in engine speed allows maximum power of the I.C. engine and consequently maximum lifting performance.

Control dashboard

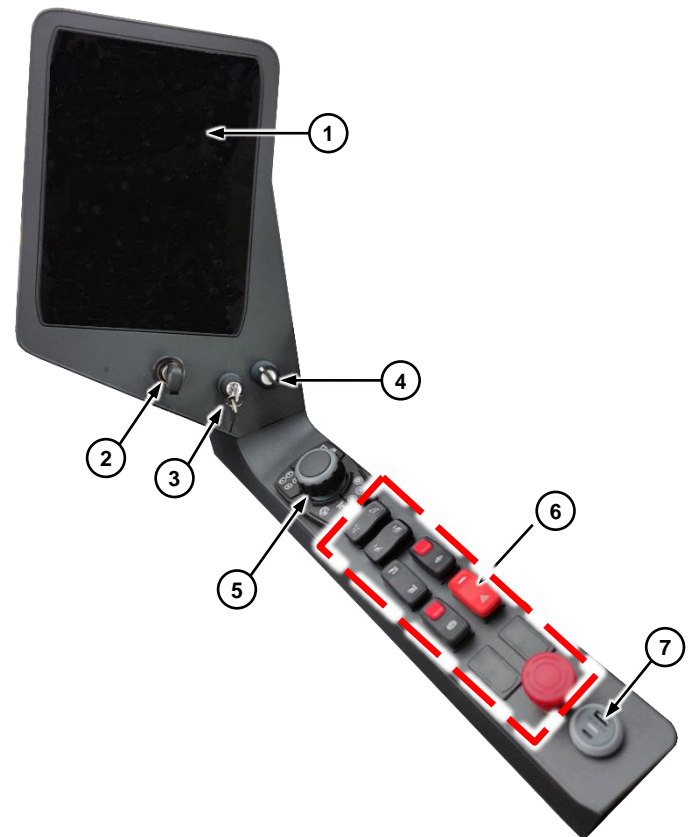

① - multiple function display

② - vehicle ignition key;

③ - safety system limit override key.

④ - key for aerial work platform radio control wiring override

⑤ - multifunctional manipulator;

⑥ - service buttons;

⑦ - USB sockets for charging electronic devices.

Vehicle ignition key.

- **O**: no electrical contact between vehicle and I.C. engine;
- **I**: general electrical contact active;
- **II**: pulse for I.C. engine start.

Safety system limit override key.

In hazardous conditions and operational necessity, the limits of the rollover safety systems can be temporarily deactivated in order to re-establish the conditions necessary to keep the vehicle and operators safe.

For this operation, the iron key must be removed from the dedicated container in the cab and inserted into the slot by pressing and turning it clockwise. Holding the key in position will automatically activate the

acoustic alarm and steady red warning light on the top of the cab to warn of the potentially hazardous situation for those working in the area near the slewing variable-reach truck.

Perform all the necessary movements to solve the emergency and restore the vehicle to safety conditions.

At the end of the procedure, unlock and remove the key and put it back in its container. Replace the glass that was broken earlier.

Key for radio control wiring override in aerial work platform.

With the aerial work platform connected to the vehicle and the radio control properly wired, if it is necessary to regain control from the cab, the black key must be removed from the dedicated box and inserted into its slot.

Once turned clockwise and held, with subsequent visual indication in the multifunctional display with dedicated banner, it is possible to control movements from the cab; in this condition, only one movement at a time is permitted, and always within the working area provided for the platform connected to the vehicle.

At the end of the procedure, unlock and remove the key and put it back in its container. Replace the glass that was broken earlier.

Multifunctional manipulator;



The joypad consists of a central controller and five quick-selection buttons that show on the display respectively:

- 1- DRIVE page with all information about the vehicle in running order

- 2- STABILIZERS page with all information about the position of the stabilisers,
- 3- LOAD page with all information concerning the working configuration and active load tables,
- 4- COMMANDS page containing all optional vehicle functions
- 5- LIMITS page containing configurable parameters for safe use of the vehicle.

As the manipulator rotates, its function is to move the command selection area, coloured blue, in the displayed page; to activate or deactivate the chosen command, press the manipulator.

NOTICE

More details on the multifunctional display pages in the dedicated section.

Service buttons

NOTICE

The buttons under the manipulator can vary in quantity, functions and arrangement depending on the vehicle model and its configuration.

NOTICE

With the “automatic page” function active in the multiple function display, when any button is pressed that commands the vehicle movements, the information page related to the activated movement is displayed, regardless of the page displayed in that moment:

- if stabilisers are activated, the “STABILIZERS” page is displayed,
- if levelling is activated, the “DRIVE” page is displayed.

Levelling on wheels

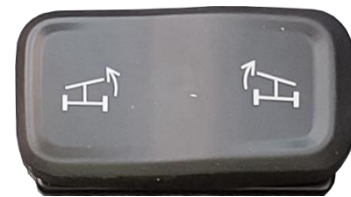

Levelling on wheels is carried out by operating the above switch under the following conditions only:

- inclination of the telescopic boom in relation to the horizontal axis less than or equal to 65°.

Pressing the switch to the right will cause the vehicle chassis to incline to the right. Pressing the switch to the left will cause the vehicle chassis to incline to the left.

NOTICE

With boom heights above 3 m, the levelling movement of the vehicle is slower for safety reasons.

You can check the levelling degree by viewing the graph in the centre of the DRIVE page of the display.

When the vehicle is levelled to a value within 3° , the moving indicator ① in the centre of the field is green; if this condition is not met, the indicator is yellow.

To the right of the field, the figure marked with ② indicates the degrees of misalignment with respect to the "X" axis.

When the vehicle is not levelled, the warning light comes on.

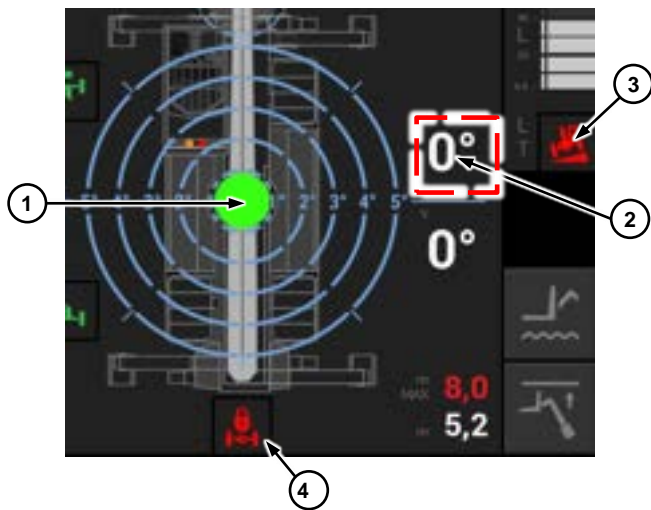

Stabiliser controls

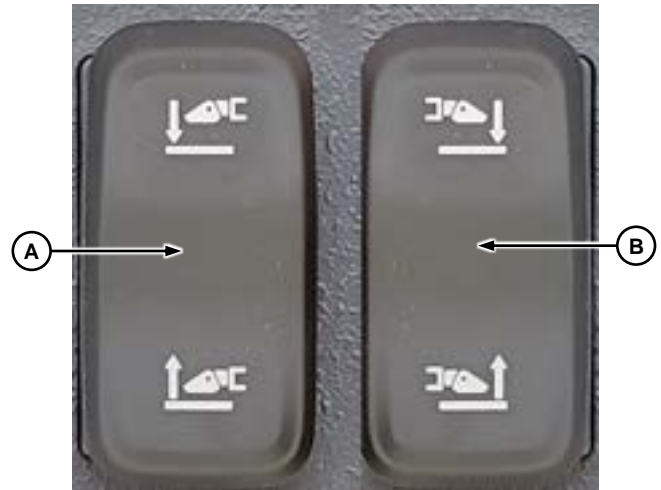

The buttons shown manage the independent movement of the stabilisers: ① left stabiliser, ② right stabiliser; when pressed in the upper portion they activate lowering of the stabilisers; when pressed in the rear portion they activate raising of the stabilisers.

The self-levelling function, when present and activated on the display in the Stabilizers page described below, enables the synchronous movement of the stabilisers, regardless of the button selected; this function manages independently the positioning of the stabilisers for levelling the vehicle.

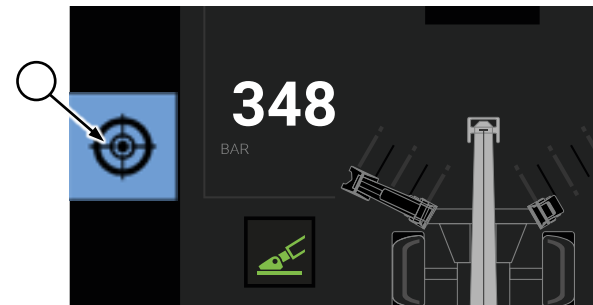

Parking brake engagement button



Press the button at the switch serigraphy to engage the parking brake; check that the dedicated red indicator light on the main page of the multiple function display comes on to indicate that it has been engaged.



For disconnection, act on the red section of the same button, which acts as a safety switch and then press it down.

When the operation is complete, the manual parking brake is disengaged.

Automatic parking brake

It is possible to enable the parking brake function in automatic mode, which engages as soon as the vehicle stops moving to unlock and allow movement as soon as the accelerator pedal is pressed with the reverse gear engaged.

When the automatic mode is activated, the indicator light identifying the activation is orange.



CAUTION

At a speed below 5 km/h, if the driver gets up from the seat, the vehicle stops automatically, and the parking brake is engaged.

Hazard lights button



Pressing it will activate the emergency light and the hazard lights simultaneously.

Activation is signalled by a light under the same rocker button and, if on, by the specific light on the DRIVE page of the display.

Red emergency stop button



Press the emergency stop button to stop the I.C. engine and interrupt all vehicle movements; when the button is pressed, the luminous message appears on the display in the cab.

NOTICE

All electronic safety systems of the vehicle remain operational.

NOTICE

To restart the vehicle, unlock the button by turning it clockwise

Double USB socket



At the bottom of the control dashboard, there is a dual USB type A and type C power supply socket with 5V output for charging mobile devices such as tablets and/or smartphones, etc.

Multiple function display



CAUTION

Using the multiple function display while using the vehicle can cause serious accidents.

It is advisable to limit the use of the display while driving to the minimum possible extent to allow prompt identification and avoid obstacles while using the vehicle.

The display has an information/operating function: from here, all vehicle parameters can be monitored in normal use and for diagnostics control, as well as certain operating functions described below can be managed and selected.

The information and functions that can be selected are collected in "pages" that, depending on the vehicle configuration and/or the vehicle operator's choice, can be visible or concealed and indicate information dedicated to the vehicle model itself.

These pages are:

- Menu** page
- Drive** page
- Stabilizers** page
- Load** page
- Limits** page
- Commands** page
- Alarms** page
- Diagnostic** page
- Password** page
- System Info** page

NOTICE

The Password pages, three in total, can be accessed by entering a numerical code and allow access to advanced level diagnostic functions and information subject to permission and authorisation by the Magni Telescopic Handlers Service, with the exception of the Level 1 page for managing parameters for operator use.

Read more in the dedicated section.

The display can be set to display pages in light or dark mode, as described later in the appropriate section, depending on operator preference and external brightness conditions.

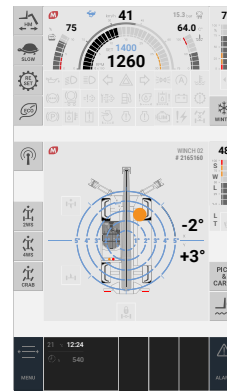

Light mode

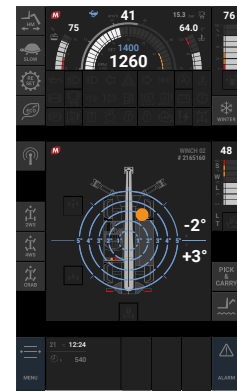

Dark mode

The pages can be consulted manually, by opening the "MENU" page by pressing the dedicated button at the bottom left of the display that shows the index of pages that can be consulted. Otherwise they can change automatically according to the command given to the vehicle: selecting the wheel drive inverter displays the Drive page, moving the telescopic boom displays the Load page, controlling the stabilisers displays the corresponding Stabilizers page.



NOTICE

The choice of whether or not to activate the automatic page change can be selected from the Level 1 Password page described below.

Drive page

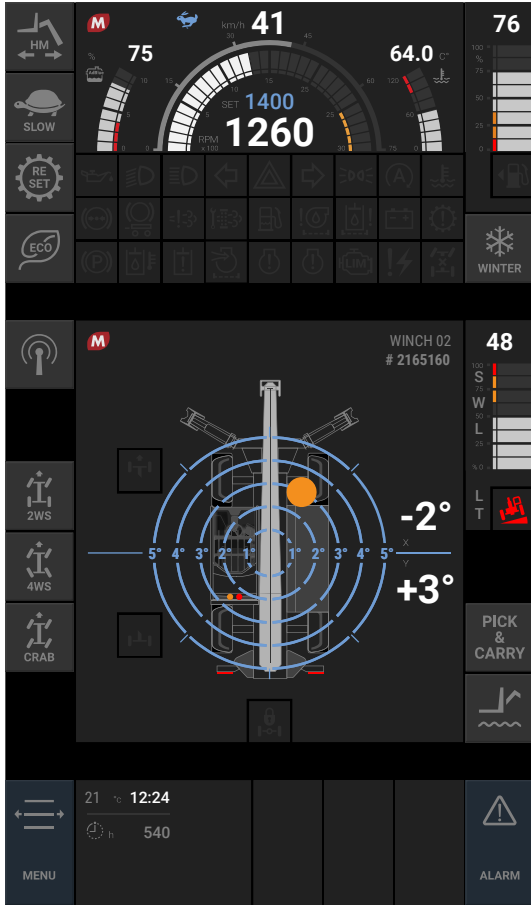

The Drive page contains general information on the operating conditions of the vehicle: such as numerical and graphic digital indicators, control and alarm buttons and lights.

Graduated indicators

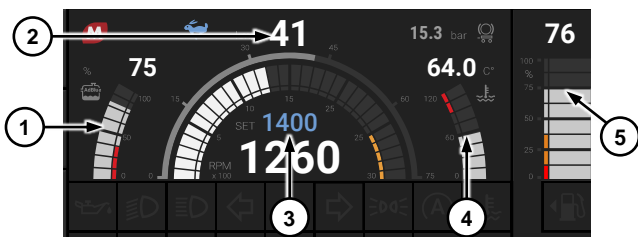

In the centre of the upper portion of the display, the AdBlue level or hydraulic fluid pressure (1) is indicated on the left with both a graduated scale and a numerical value, depending on the vehicle models, whether or not they are equipped with a urea tank; in the centre at the top is the travel speed on wheels indicator (2) under the rev counter of the I.C. engine (3). In white is the instantaneous engine rev value, in blue the engine revs set manually by the operator for specific operations.

To the right of the rev counter graph is the graduated scale with the numerical value of the cooling circuit water temperature (4).

On the far right of the display is the graphic and numerical fuel level indicator expressed in percent (5).

Levelling indicator

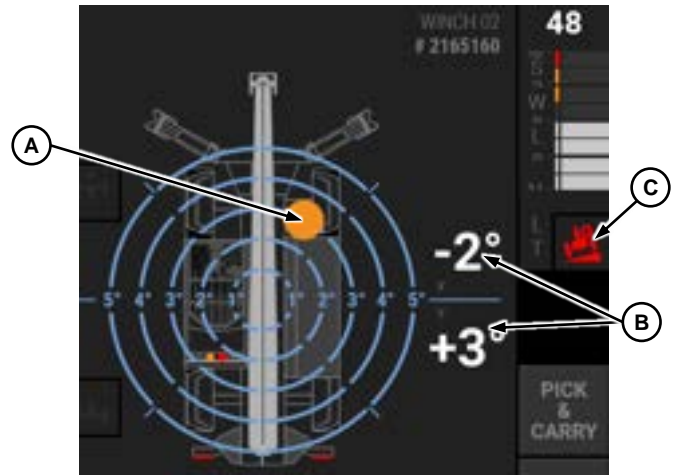

The centre of the page shows the active graph indicating the position of the vehicle chassis relative to an ideal perfectly horizontal flat surface.

The digital spirit level (A), when perfectly centred, is green; as it moves, depending on the angles detected, it provides a graphic indication of vehicle levelling by means of the two numerical values (B) beside it, which summarise the inclination value with respect to the longitudinal and transverse axes: beyond 3° of displacement it turns yellow.

The tipping alarm light indicated by the letter (C) is activated:

- with vehicle on wheels, when the angle of the chassis with respect to the horizon exceeds $\pm 4^\circ$ in the longitudinal axis and $\pm 3^\circ$ in the lateral axis;
- with vehicle stabilised at ± 1 in both axes.

Anti-tipping system indicator

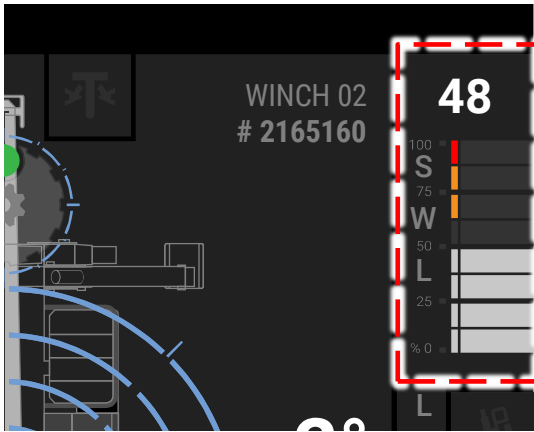









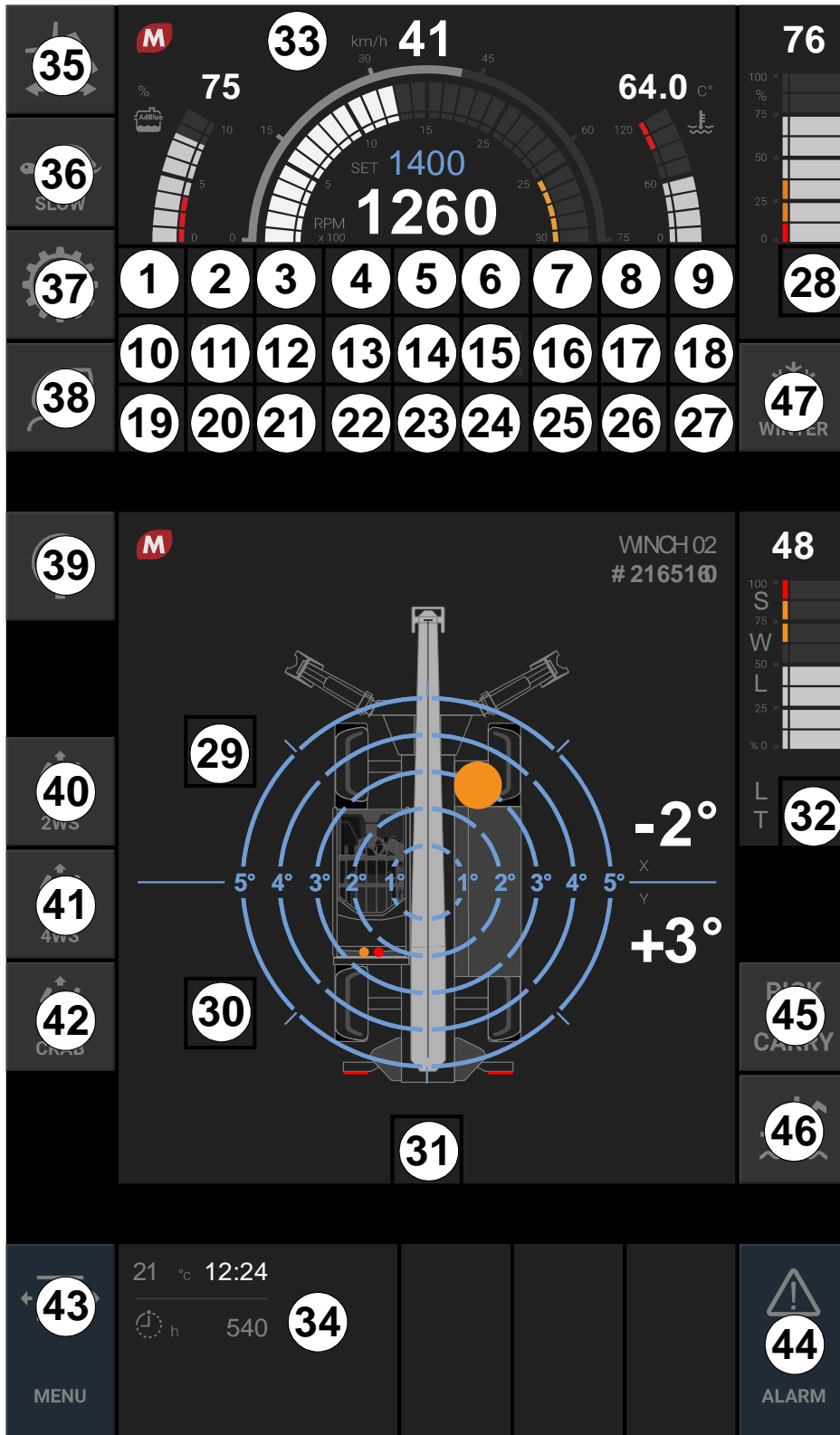









To the right of the levelling indicator is a graduated scale with a numerical value above it that shows, in percentage terms, the load value applied to the equipment installed at the boom end in relation to the maximum rated load value of the equipment itself.

Within a detected load range of 89% the vehicle works normally, with a detected load range between 90% and 99% the red beacon above the cab lights up in flashing mode and the safety buzzer sounds intermittently; when the maximum value is exceeded, the red beacon above the cab remains steady on, the safety buzzer sounds continuously, and the related warning is displayed.























List of warning lights and functions that can be selected in the Drive page



1		Low engine oil pressure	Graphic variation depending on vehicle configuration
		SCR fault	
		Low AdBlue level	
2		Low beams	
3		High beams	
4		Left-side direction indicators	
5		Hazard lights	
6		Right-side direction indicators	
7		Road lights	
8		Active Start & Stop system	
		Start & Stop system in stand-by	
9		High coolant temperature	Graphic variation depending on vehicle configuration
		Engine preheating	
10		Low brake oil pressure	
11		Low trailer brake oil pressure	
12		Fault in exhaust gas system	
		Exhaust gas filter failure	
13		DPF regeneration required	

14		Presence of moisture in the fuel tank	
15		Hydraulic fluid pump filter failure	
16		Clogged hydraulic fluid filter	
17		Low battery level / Electrical generator failure	
18		Transmission failure	
19		Manual parking brake engaged	Colour variation depending on set braking mode
		Automatic parking brake engaged	
20		High hydraulic fluid temperature	
21		Hydraulic system fault	
22		Engine air filter clogged	
23		Engine failure	
24		Engine fault warning	
25		Engine in limited mode due to errors in the control unit	
26		Electrical system failure	
27		Active boom suspension	
28		Low fuel level / refuelling required	
29		Front axle aligned	

30		Rear axle aligned	
31		Rear axle lock active	
32		Tipping warning	
33		Speed indicator - active fast movements	Graphic variation depending on the set movement speed mode
		Active slow-motion speed indicator	
34		Outside temperature indicator / Daily time / Vehicle operating hour counter	
35		“Handling Mode” activation button	
36		“Fast movements” activation button	
		“Slow movements” activation button	
37		“Reset” button for vehicles equipped with Rexroth transmission pumps	
38		“Eco mode” activation button	
39		Radio control connection enable button	
40		Front axle steering wheel mode selection button	
41		Four-wheel steering mode selection button with concurrent axle	
42		Parallel-axle four-wheel (crab) steering mode selection button	
43		Link button to list of searchable pages	

44		Cross-reference button to active alarm list page
45		Button for Pick&Carry display
46		“Boom suspension” function activation button
47		“Winter mode” activation button

NOTICE

The indicators and selection buttons described here are subject to variations in quantity and position depending on the vehicle models handled and their implementations.

NOTICE

The warning lights described here are shown lit, in normal non-use condition they have a dark grey background.

Handling mode





This function enables an increase in the oil flow rate to the service pump and thus in the speed of movement as soon as a hydraulic command is given; this increase does not affect the transmission pump controlled by the accelerator pedal.

Speed of movements



The hydrostatic transmission of Magni Telescopic Handlers has two speeds:

- slow mode, called "tortoise", light no. **33**, ;
- fast mode, called "hare", light no. **33**, .

In "tortoise" mode, the transmission allows the vehicle to move at low speed. Use this mode for precision movements and to move the load.

In "hare" mode the transmission uses both speeds and makes it possible to reach maximum speed. Use this mode for travelling on roads or for rapid movements in the work area.

The active mode is shown by indicator light no. **33**, shown above, while selection button no. **36** indicates the mode that can be set as an alternative to the displayed operating mode.



CAUTION

You can switch between the two modes only under the following conditions:

- vehicle stopped;
- brake pedal pressed;
- gear selector in NEUTRAL position.

If these conditions are not respected, they are indicated individually on the display with specific warning banners.

To switch from "hare" active mode to "tortoise" mode, press button **36** representing the "tortoise". Conversely, to switch from "tortoise" active mode to "hare" mode, press button **36** representing the "Hare".

Reset



This button is displayed for vehicle models fitted with Rexroth transmission pumps. In case of failure to change speed mode or if there is difficulty in engaging the desired speed, stop the vehicle, press the button and accelerate gently to facilitate engagement of the transmission gears.

Eco mode



This function, when enabled, allows engine speed to be managed to reduce fuel consumption and exhaust emissions: once the maximum travel speed has been reached, and maintained, the engine revs automatically decrease, to then increase again should road conditions require it: as in the case of an increase in gradient to be overcome and a sudden drop in speed.

Radio control connection



Pressing this button enables, when present, the connection of the radio control to drive the vehicle from the outside.

Steering modes



The buttons above enable changing the vehicle steering mode according to the graphics shown:

- two-wheel steering: on front axle
- four-wheel steering with concurrent axles for minimum steering range
- four parallel-axle "crab" steering wheels for lateral movement

mode change takes place only under the following conditions:

- vehicle stopped,
- axles, front/rear, aligned confirmed by the illumination of the warning lights



NOTICE

In the condition where the front and rear axles are misaligned, it is recommended to initially centre the rear axle by selecting the four-wheel mode; when the specific light **30** on the display comes on, activate the selection of the front steer axle only until alignment. Now select the desired mode.

Boom suspension



NOTICE

This function is available only if the specific equipment is present on the vehicle.

The telescopic boom suspension is designed for operating the vehicle on uneven ground with loads raised.

To use this function the following conditions must be respected:

- vehicle on wheels;
- telescopic boom height from the ground less than 3 metres;

To activate the function, press the dedicated button, which turns from grey to blue, and command a small upward movement to the telescopic boom.

This command is reminded by a specific visual signal on the multiple function display.

The boom suspension only works in the presence of the aforementioned conditions: if said requirements are not satisfied during a movement, the function is automatically disabled; if, with the vehicle moving, the parameters required fall within the envisaged limits, the boom suspension is automatically reactivated.

When the slewing variable-reach truck stops, the function is deactivated; to reactivate it repeat the procedure described above.

Winter mode



NOTICE

This function is available only if the specific equipment is present on the vehicle.

Winter Mode has been designed for vehicles working in particularly cold weather conditions: by activating it with the engine running, it causes the I.C. engine to increase its revs to facilitate the heating of the service hydraulic circuit and the heating of the cab itself; if the operator sits on the driver's seat, the engine revs are reset to the minimum speed.

Pick & Carry



This button enables the display of data summarising the movement of mounted equipment by road; specifically:

- point of load application,
- maximum travel speed,
- position of the telescopic boom
- maximum lifting angle of the telescopic boom;
- maximum height of the load from the ground
- maximum load capacity
- maximum permitted vehicle travel angles.

M ATTACHMENTS	PICK & CARRY	EN 1459 / AS 10896.1
MAX DEGREES	2815 mm 9' 3"	
	MAX SPEED	1,4 km/h
	BOOM STATUS	FULLY RETRACTED
	BOOM ANGLE	22 °
	H GROUND	500 mm
	MAX CAPACITY	2000 kg
Full info on the operator manual		

(example)

Stabilizers page

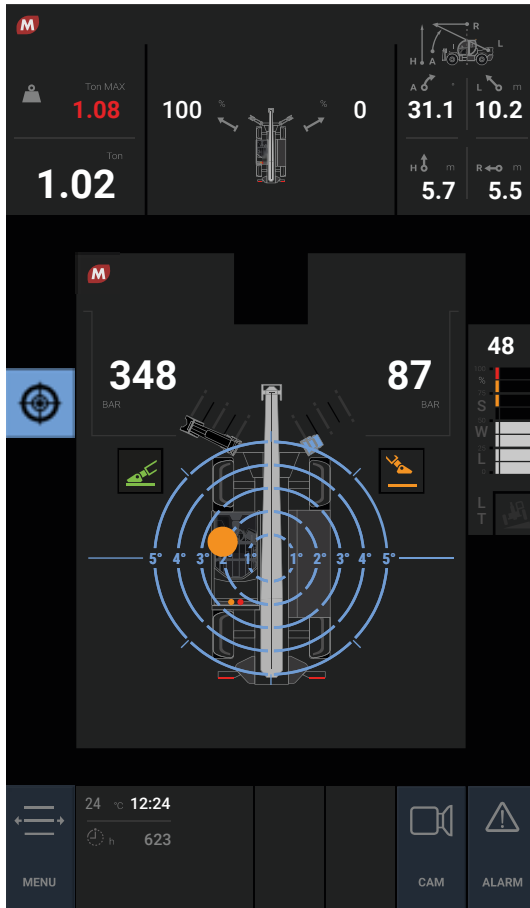

The **Stabilizers** page mainly contains general information on the activity status of the stabilisers.

Graduated indicators

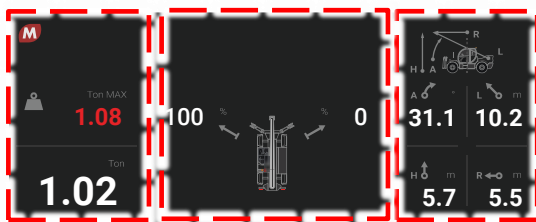

The upper portion of the page, which is also indicated on the Load page, described below, displays the nominal maximum capacity of the installed equipment and the capacity measured in real time on the left. The position of the stabilisers is displayed in the centre in percentage:

- 0% indicates stabiliser not on the ground;
- 100% indicates stabiliser on the ground.

On the right, the upper part of the display summarises the use status of the telescopic boom with four parameters:

- **A**: boom lift angle measured in relation to the ground from equipment hinge pin axis.
- **L**: extension length: to equipment hinge pin axis when not present or specific load application point for installed equipment;
- **H**: boom height measured from the ground to the equipment hinge pin axis when not present or specific load application point for installed equipment;
- **R**: the horizontal distance measured from the tangent of the front axle wheel perpendicular to the ground and the equipment hinge pin axis when not present or specific load application point for installed equipment.

In the central portion of the page, in addition to the graph depicting the levelling of the slewing variable-reach truck described above, there are the button to enable self-levelling (1), the indicator lights (2) that identify the position of the stabiliser with respect to the ground, and the pressure exerted by the hydraulic circuit on each stabiliser (3).

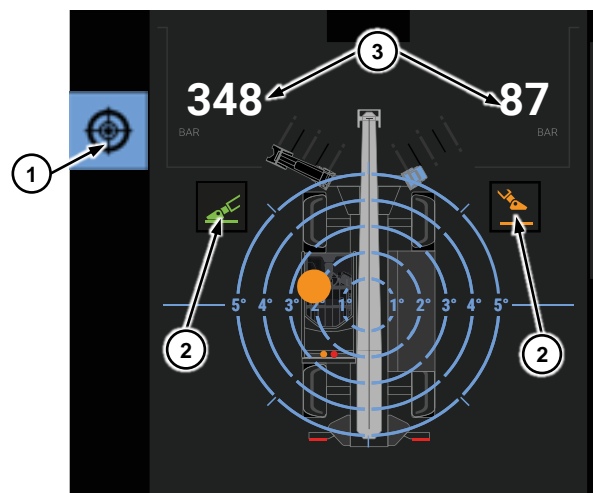



Self-levelling



With the light blue button on, the vehicle's self-levelling is enabled: as described, this enables the synchronous movement of the stabilisers, independently of the button selected on the dashboard to the right of the seat; this function independently manages the positioning of the stabilisers for levelling the vehicle.

The icons (2), according to their graphics, summarise the position of the stabiliser foot:

-  closed or without ground contact
-  moving (opening/closing)
-  resting on the ground

Limits page

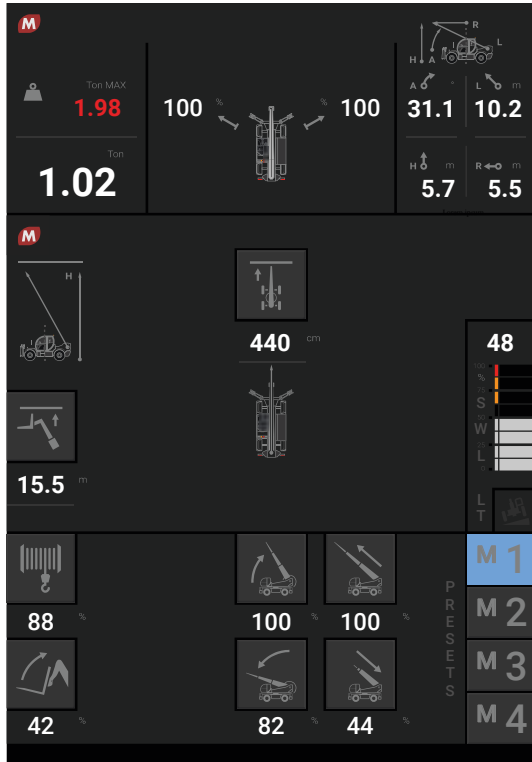

The **Limits** page is structured so that it is possible to set operational limitations to the vehicle's movements should it be necessary to operate more safely depending on the working context.

Limitation of telescopic boom extension

The upper portion of the page contains the same information as described in the section on the *Stabilizers* page.

The central portion is dedicated to the extension limitations of the telescopic boom.

In the presence of obstacles in the work area, such as pillars, walls, ceilings, vegetation or other, having defined the position of the vehicle within the work area, in order to limit the risk of impact and increase the operator's safety level, it is possible to set horizontal and vertical extension limitations to the telescopic boom. When the set size is reached, the vehicle stops movement, avoiding collisions with the obstacle previously considered.

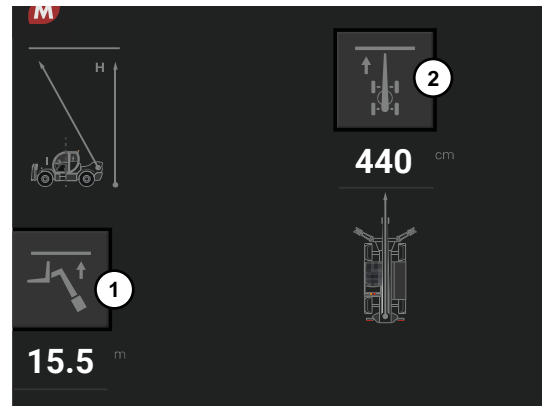

Buttons ① and ② enable respectively:

- ① Extension limitation in height,
- ② Left/right frontal extension limitation with respect to the axis of the vehicle chassis.

To set the limits, position the telescopic boom in the required direction and at the desired measurement, then press the button for 3 seconds in the direction for which you are setting the limit. At this point the software memorises the value corresponding to the measurement detected and displays it. When the function is active, recognisable by the light blue coloured button, the vehicle will stop when this value is reached; deselecting the button, (grey colour) cancels the desired limit.

NOTICE

In order to perform a correct limitation calibration, define the limit measurement with interchangeable equipment mounted at the head of the boom knowing the size of the load to be handled.



CAUTION

Extension limitations, once set, remain in memory; to change the value according to the new operational situation, repeat the setting and enabling procedure described above.

Hydraulic movements speed

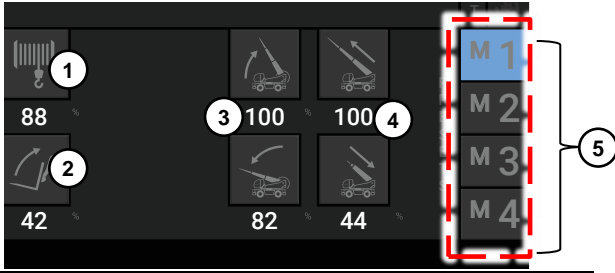

The lower portion of the display is dedicated to managing the hydraulic operating speeds of the vehicle and the installed equipment, the buttons manage:

- ① the hydraulic fluid flow rate at boom head - OPTIONAL use
- ② the speed of the swing command;
- ③ the telescopic boom up/down speed;
- ④ the telescopic boom extension/retraction speed.

The four buttons indicated by number ⑤ identify the four storable and independent configurations to manage the hydraulic speeds listed above.



CAUTION

The values below the buttons identifying the adjustment action indicate the movement speed as a percentage (%):

- 100: full movement speed as set by the factory,
- 0: no movement speed = vehicle locked.

so, setting decreasing values slows down the movement.

Setting the movement speed limits

To set hydraulic speed values different from the factory settings, first select one of the four programme buttons (**M1**, **M2**, **M3**, **M4**): the selection is highlighted by the colour of the chosen button changing from black (off) to blue (selected).



When one of the four programmes is selected, the buttons showing the functions with adjustable speed change colour from barred black (not selectable) to grey (selectable):



If the vehicle still has factory parameters, all six parameters are set at 0.

Select the movements concerned one by one and set the desired value:

- press the icon of the function to be set, e.g. ② (*swing speed*), with confirmation of selection identified by the colour changing to blue until the numerical setting keypad appears on the display.

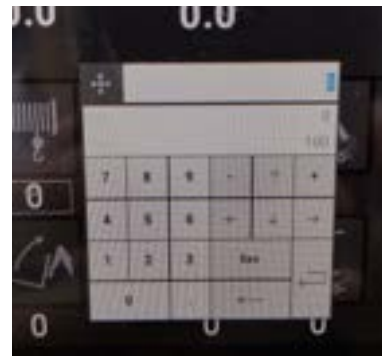
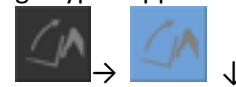

- enter the speed percentage value of the desired function and confirm by pressing the ENTER button on the same keypad to record the desired value.

Once this procedure is performed, the set value for the swing speed remains active until the previously selected programme button (in this case **M1**) is deactivated or the desired speed value is changed.

Load page

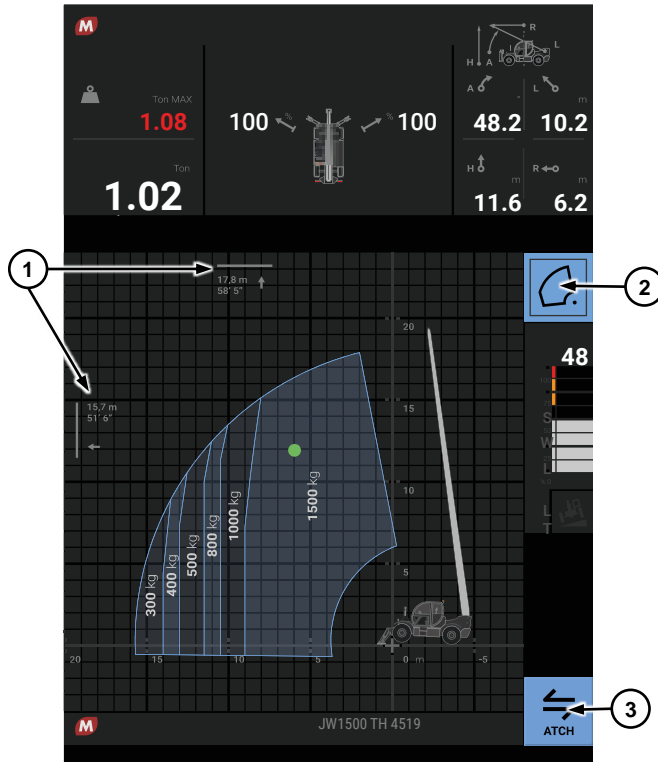

The upper portion of the page contains the same information as described in the section on the **Stabilizers** page.

The central portion displays the working area and the dedicated load diagram with an indication of the maximum permissible depth and height limits ①.

Graphically, the information that can be displayed by pressing ② are:

- static,
- dynamic with a side view,

Button ③, when pressed, temporarily displays the summary data of the interchangeable equipment coupled to the vehicle such as model name and load application points, as in the example below.

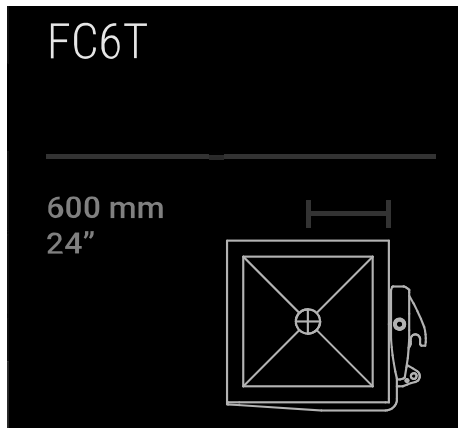

Flow rate diagram in static view



In this configuration, a green mark ① in the display identifies the position of the load application point within the overall working area divided into load ranges, each limited in depth and height according to the permissible load.

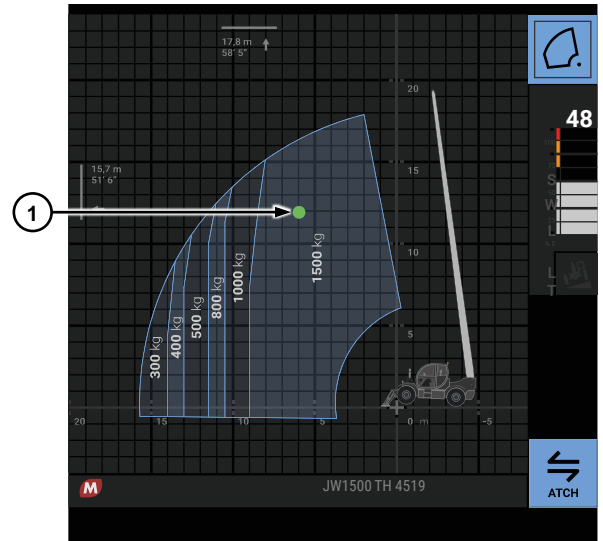

Flow rate diagram in dynamic view



In this configuration, the load diagram is self-compiled according to the position of the load application point detected as a function of the equipment installed at that particular stage of operation, each time displaying the height and depth limits allowed by the vehicle's safety system.

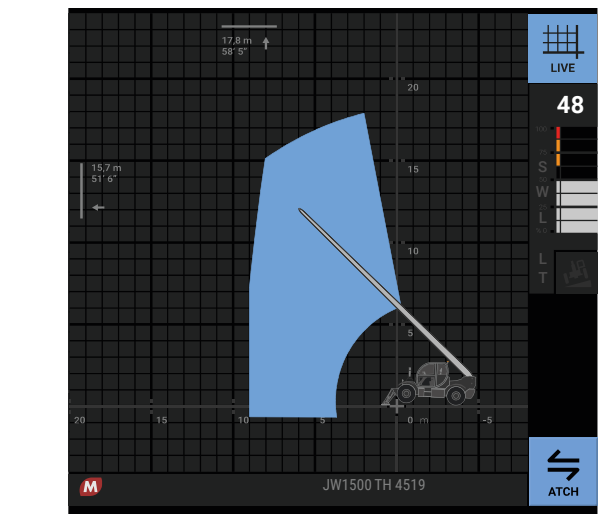

Commands page

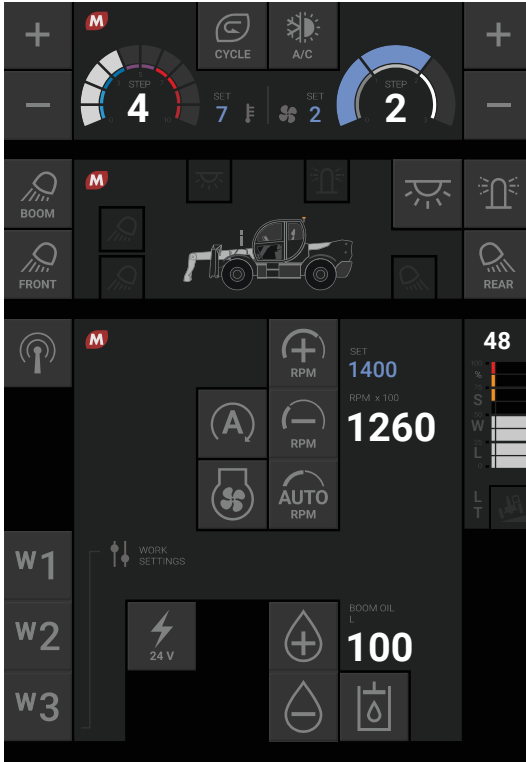

This page contains information and controls of the cab air-conditioning system, controls for activating the exterior working lights and cab reading lights, and buttons for activating accessory functions.

Air-conditioning system

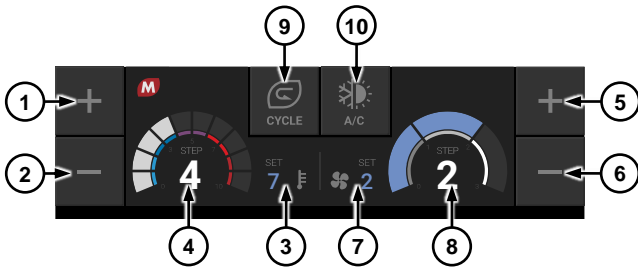

Buttons ① and ② adjust the cab air temperature on a graduated scale from 0 to 10: the selected value is displayed by the indicator ③, while the graduated scale ④ indicates the temperature status in relation to the selected value.

Buttons ⑤ and ⑥ adjust the air flow rate from the cab's interior air vents on a graduated scale from 0 to 3: the selected value is displayed by indicator ⑦, while the graduated scale ⑧ indicates the fan speed in relation to the selected value.

The ⑩ button activates the air-conditioning system with air conditioning.

Auxiliary lighting system

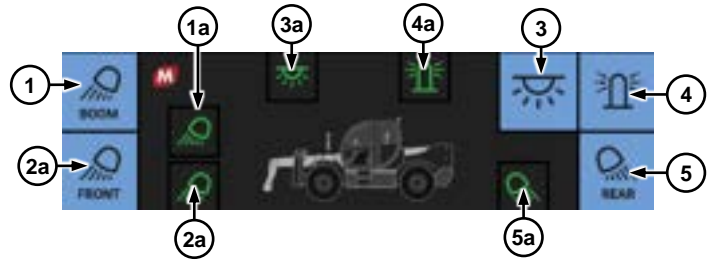

Button ① activates the work lights at the head of the telescopic boom; when activated, the corresponding indicator light 1a lights up.

Button ② activates the front work headlights placed on top of the driving cab; when activated, the corresponding indicator light 2a lights up.

Button ③ activates the work tail lights placed on top of the driving cab; when activated, the corresponding indicator light 3a lights up.

Button ④ activates the orange beacon placed on top of the driving cab; when activated, the corresponding indicator light 4a lights up.

Button ⑤ activates the reading light inside the driving cab over the operator's seat; the corresponding indicator light 5a lights up.

Ancillary functions

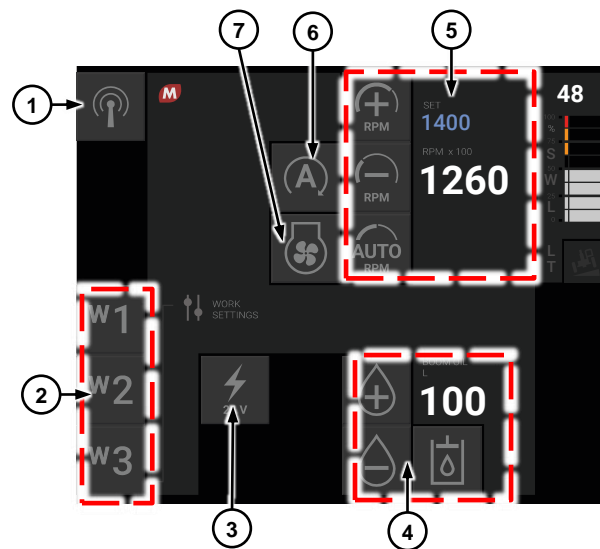

The central portion of the page enables additional functions described below:

- 1- radio control enabling,
- 2- working mode
- 3- 24V boom head
- 4- continuous hydraulic fluid,
- 5- idle speed/engine control,
- 6- Start & Stop
- 7- Fan reversal

NOTICE

This page may vary depending on the optional functions enabled on the vehicle.
Please contact Magni Telescopic Handlers Service in case of lack of adequate description.

Radio control connection



Pressing this button enables, when present (optional), the connection to the radio control to drive the vehicle from the outside for types of work requiring a different viewpoint.

Working mode



Buttons **W1**, **W2** and **W3**, identify 3 distinct modes of setting the vehicle's movement speeds: for certain operating phases or to move a specific type of equipment, the operator can select a specific setting:

W1: factory standard settings usable with all types of interchangeable equipment;

W2: slowed down hydraulic movement speed settings, can be used with all types of interchangeable equipment and recommended for handling suspended loads (hooks, ropes with hooks);

W3: setting of higher movement speeds selectable only with interchangeable equipment such as shovels or buckets.

NOTICE

Depending on the interchangeable equipment installed, the availability of working modes may vary: this condition is indicated by the specific non-enabled mode crossed out.

NOTICE

During the use of aerial work platforms, these modes are bypassed by specific safety settings.

24V electrical output at boom head



Press this button to enable the power socket (optional) present at the top of the boom for supplying current to the accessories that may be fitted.

Continuous hydraulic fluid

This function enables the flow of fluid to the outlets at the boom head for the use of specific equipment that needs the function: e.g. aggregate mixers.

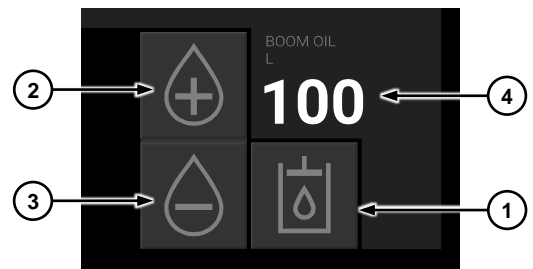

To enable it, press button ①; buttons ② and ③ adjust the flow speed indicated by the numerical value ④ representing the percentage of flow in relation to the maximum flow rate.

Idle speed/engine control

In this portion of the page, the minimum value of the I.C. engine can be selected.

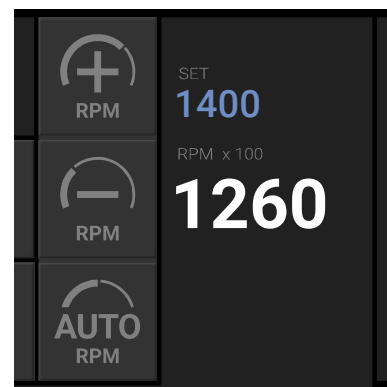

The **AUTO RPM** function enables the automatic increase of I.C. engine speed according to the demand for hydraulic service fluid: with the engine at idle (850rpm) at any hydraulic command given (stabilisers, telescopic boom, etc.) the engine increases the speed supporting the service pump in order to provide maximum efficiency.

The **RPM +/-** buttons allow you to set an idle speed value according to your needs: the set value will be indicated with **SET**; this information, once set, is also shown on the **DRIVE** page together with the tachometer's numerical graphic indicator.



Start & STOP



When enabled, this function allows the I.C. engine to be switched off 1 minute after the last command given to the vehicle.

To restart the engine, press the brake pedal.

Enabling of this function is indicated on the **DRIVE** page by a specific light:



: green indicates active function and function in stand-by with engine running



: orange indicates the function is active and operating with the engine off.



CAUTION

With the function active, when leaving the driver's seat, the engine restart by means of the ignition key is indicated on the display.



CAUTION

In low battery condition, the Start&Stop device is deactivated, allowing the engine to power the alternator and recharge the batteries.

Cooling fan rotation reversal



This function enables the program to reverse the direction of rotation of the cooling fan: this makes it possible to blow air outside the engine compartment to clean the aeration surfaces by removing accidental deposits of material potentially harmful for the equipment.

The inversion sequence involves two minutes of air suction and one minute of expulsion at cyclic intervals of 20 seconds of slowing down of the fan speed in order to protect its mechanism.

Password Pages

Pages protected by password give access to advanced information and/or settings.

NOTICE

The following descriptions on the Password pages may differ from vehicle model to vehicle model depending on the specific configuration.

To enable these pages please contact Magni Telescopic Handlers Service.

Level 1 password:

- clock and 12h/24h format setting,
- multiple function display brightness adjustment,
- cab reading light brightness adjustment,
- management of the automatic change of display pages on the multiple function display,
- management of the language of the texts displayed on the multiple function display,
- management of the value measurement system: metric/imperial,
- management of automatic rear camera signal activation when reverse gear is engaged,
- light/dark lighting management of the multiple function display,
- automatic steering function enabling,
- enabling of the automatic parking brake,
- LIMITS page display enabling,
- enabling of automatic levelling always operational.

Level 2 page:

In addition to the display of Level 1 page data,

- management of access passwords to the Level and Level 2 pages,
- maintenance hour meter management,
- optional TWIN POWER enabling, when present,
- continuous hydraulic fluid function enabling,
- LIMITS page display enabling,
- manual engine speed management enabling,
- stabiliser extension setup function enabling,
- optional WINTER MODE enabling, when present,
- enabling of compulsory closing of stabilisers during translation.

Level 3 page:

In addition to the display of Level 1 and 2 page data,

- calibration management of the vehicle's functional parameters.

System Info page



This page groups together the master data of the vehicle and its components, both hardware and software: here you can check the name of the vehicle model, its serial number, the type of engine installed, the type of transmission installed, the various versions of software installed to manage the control and diagnostic units.

Air vents

In the cab, there are air vents adjustable in orientation located in front of the driver to the right of the steering column on the hat rack located behind the seat, and at the base of the entry door pillar; they are all adjustable in air flow and temperature in the *Commands* page of the display, as described above.

There is also a windscreen-specific air diffuser located in the crossbar that incorporates the front windscreen wiper.

Service compartments for the vehicle driver

In the cab, there are service compartments to the right of the driver's seat:

- document pocket ①,
- mobile/tablet pocket ②,
- beverage holder ③.



Safety keys container

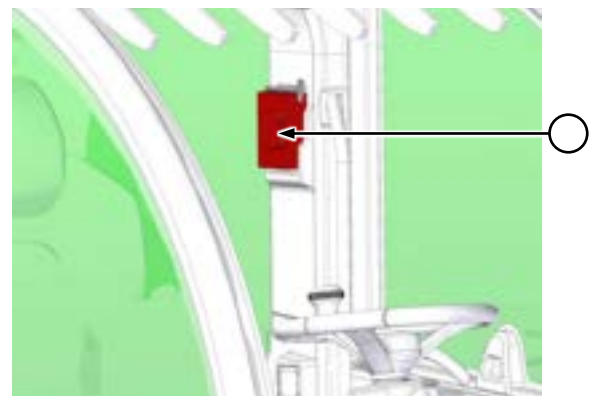

The container for the keys used for excluding the safety systems is fitted on the left jamb inside the driver's cab.

The container contains two keys:

- key for exclusion of the rollover protection safety systems, with metallic grip;
- key for exclusion of the lift platform safety systems (optional), with plastic grip.

Should it become necessary to use the keys enclosed inside, take the hammer located above the container and break the protective glass.

Once the safety procedure is complete, replace the key(s) and restore the protective glass.

Vehicle radio

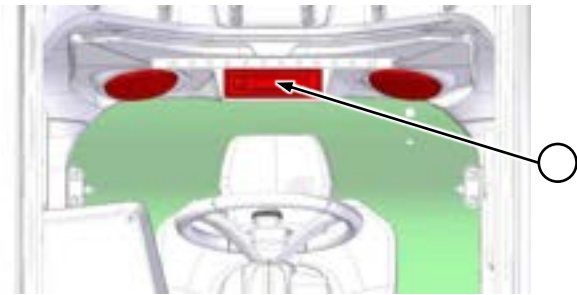

The vehicle radio is present on the rear covering of the cab behind the operator's head. The speakers are present between the driver's seat and the rear window. The radio is included in the standard vehicle supply. For operation of the radio installed, refer to the Instruction Manual included in the package delivered with the vehicle.

Reading light

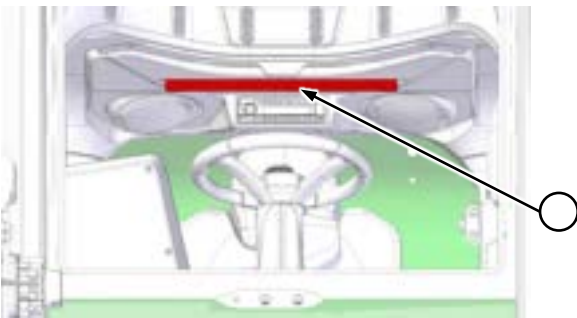

A ceiling light is located on the cab roof panel: this switches on automatically when the cab door is opened, and switches off when the engine is started.

It can be activated for document reading by means of the appropriate button on the *Commands* page described above and shown here.



Sunshade

Positioned above the driver's seat is the retractable sunshade ①: this, when grasped by the handle, can be pulled out of its seat and extended in two different stages, ② and ③, depending on the driver's needs.

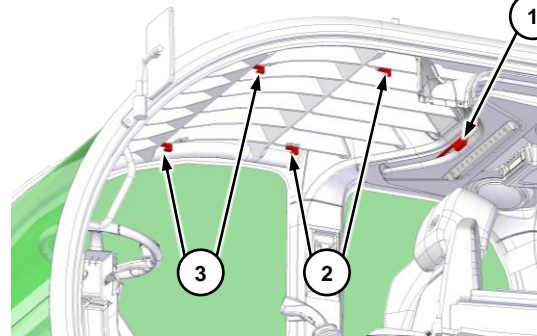

Radio control battery charger

In the lower portion of the left-hand pillar of the cab is the battery charger for the radio control (when present in the vehicle)

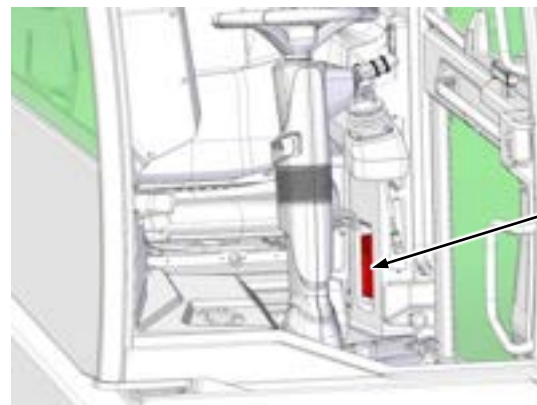

Radio control housing (Optional)

Behind the driver's seat there is a place to store the radio control when present and not in use.

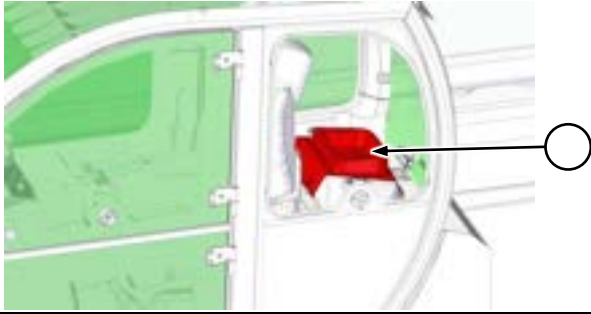

External elements

Work and emergency lights

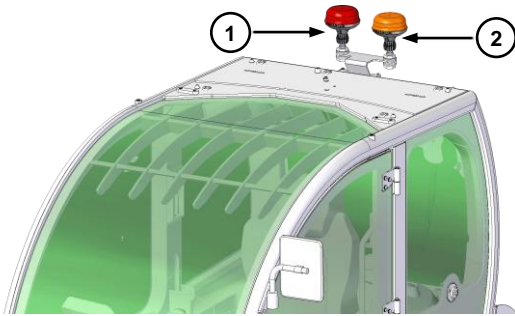

Above the cab there are:

- the red beacon ① which is activated when the limiting working conditions are reached and warns people outside of a possible dangerous situation,
- the orange beacon ② with the function of signalling a moving vehicle and activated from the multiple function display, as described above.

Rear view mirrors

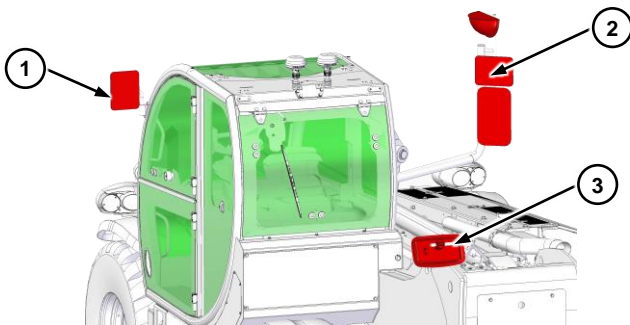

The vehicle is equipped as standard with five rear-view mirrors: one on the left ①, installed directly on the cab, three on the right ② installed on a support structure bolted to the right side of the vehicle chassis, and one installed on the rear ③ of the chassis to view the blind spot behind the vehicle.

The rear-view mirrors on the right make it possible to simultaneously display the rear area and the area of the ground adjacent to the side of the vehicle.



CAUTION

Adjust the rear view mirrors before operating the vehicle to give the operator maximum visibility of the area adjacent to the vehicle.

Headlights

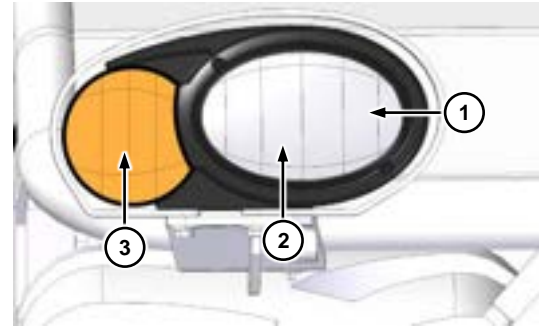

The headlights consist of the following lights:

- Position light ①,
- Low/high beam ②,
- Direction indicator ③.

Selection is controlled by means of the light switch lever on the steering column in the cab.

Tail lights

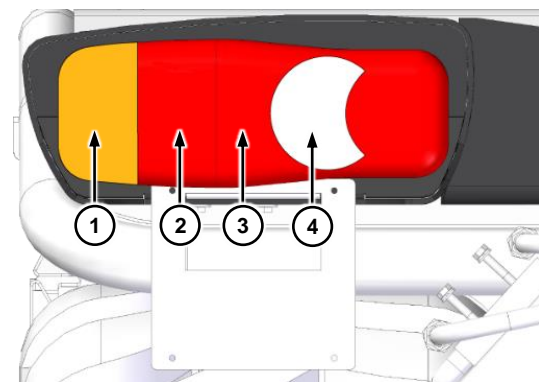

The taillights unit consists of the following lights:

- Direction indicator ①;
- Stop light ②;
- Position light ③; (+ licence plate light for left light cluster);
- Reversing light ④.

The selection for position lights and direction indicators is controlled by the light switch lever on the steering column in the cab. The STOP light is activated by pressing the brake pedal of the vehicle; the reverse light is activated by means of the FNR button on the right joystick in the cab.

For ease of operation at work and to limit the protruding parts of the vehicle, both of the rear light units can be turned upwards by removing the butterfly head screw ①, lifting the light unit towards the vehicle chassis, and then locking it with the previously removed butterfly head screw.

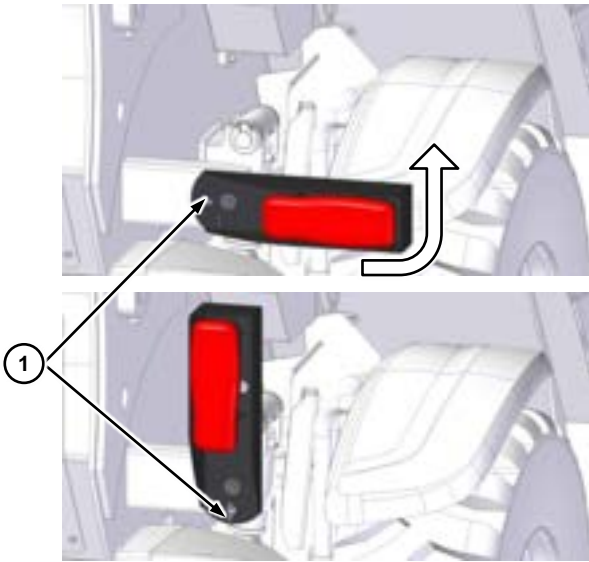

The vehicle can be equipped with additional LED work lights positioned at the end of the telescopic boom frame: these are managed on the *Commands* page as described above and shown here.

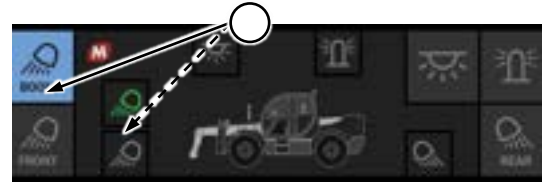

Additional cab work lights

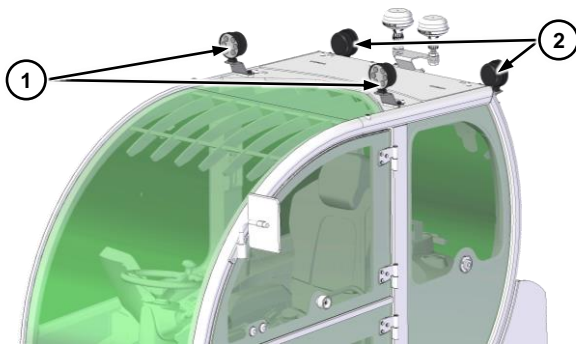

Shear pin housing for interchangeable equipment

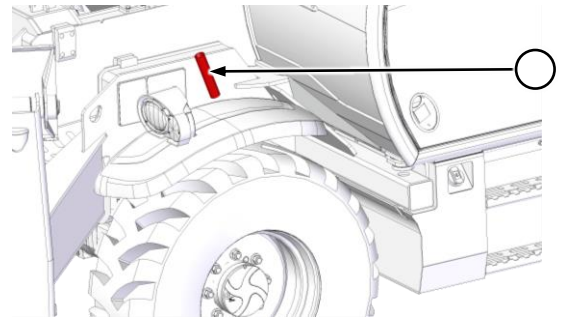

The vehicle can be fitted with additional LED work lights positioned above the cab: these, two at the front ① and two at the rear ②, are managed on the *Commands* page as described above and shown here.

The housing of the shear pin for the quick-fit coupling of the equipment is present in the front part of the vehicle chassis near the left mudguard, opposite the driver's cab.

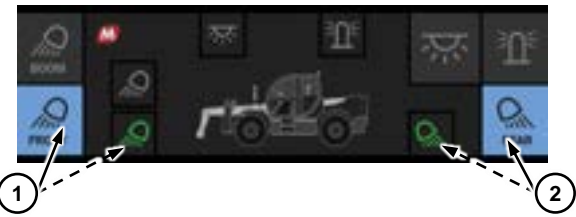

CAUTION

The shear pin must also be on the vehicle so as to be available when required.

Always fit the shear pin in its housing when not in use.

If placed in an unsuitable part, the shear pin may get jammed between the moving parts of the vehicle, causing serious problems.

Additional work lights on the telescopic boom (Optional)

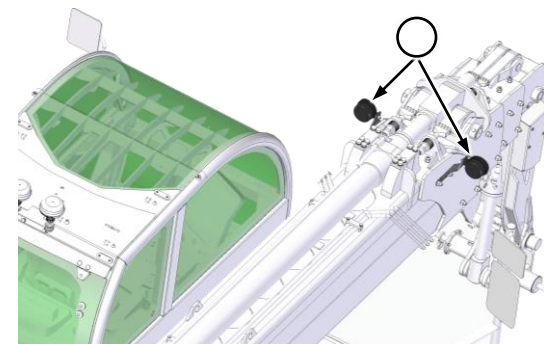

Anchoring points

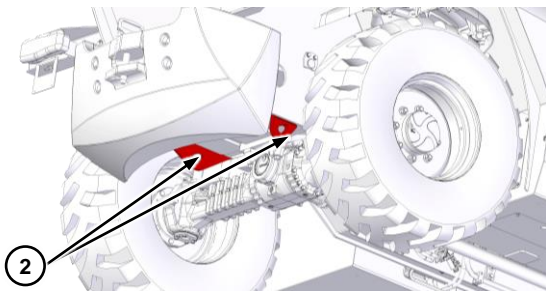
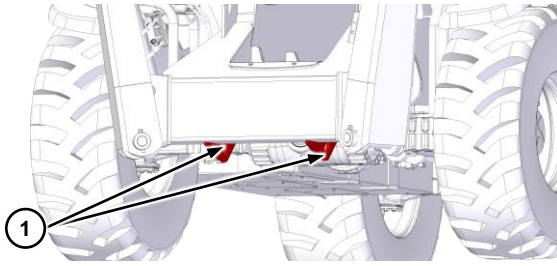

The vehicle is provided with four anchoring points, in the front part of the chassis ① and in the rear part ②, all marked by a specific sticker:

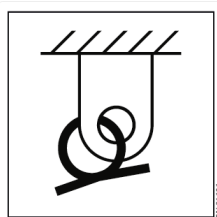

WARNING

Unless otherwise indicated in this Manual, never fix anchoring devices to other parts of the vehicle.

Tow hook

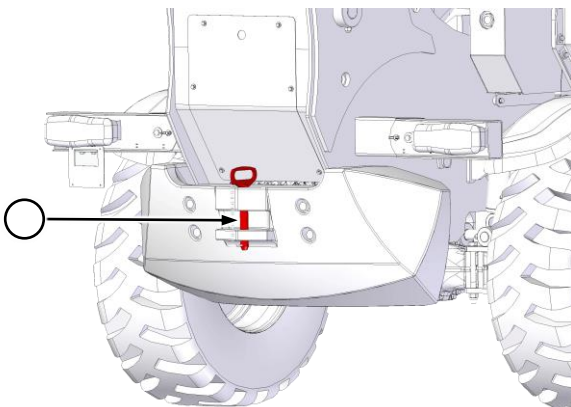

The vehicle is provided with a tow hook positioned in the rear part of the chassis.

When using the hook, ensure that the pin is properly secured by the attached steel chain-bound safety cotter pin.



CAUTION

Do not tow trailers with a mass greater than that indicated by the specific sticker on the hook for each vehicle model.

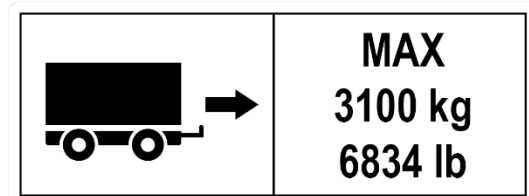

WARNING

Do not connect towing devices other than the tow hook as anchoring points to parts of the vehicle.



WARNING

The towing operations must always be carried out by personnel appropriately trained in compliance with the laws in force.

Quick-fit coupling for the equipment

The vehicle is equipped with an interface, hereafter referred to as a *quick-fit coupling*, to be combined with interchangeable equipment with specific functions: fork attachment plates, winches, lifting hooks, aerial work platforms, etc.

This quick-fit coupling, depending on the end customer's specifications, can be of two types: "I" or "U".

“I” and “U” couplings

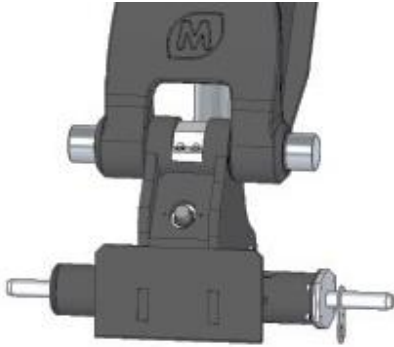

The “I” coupling (with Magni Telescopic Handlers patent) is designed to be more rigid, more compact, in comparison with those of competitors and is designed solely for equipment designed and produced by Magni Telescopic Handlers S.r.l. (or licensed) with similar coupling.

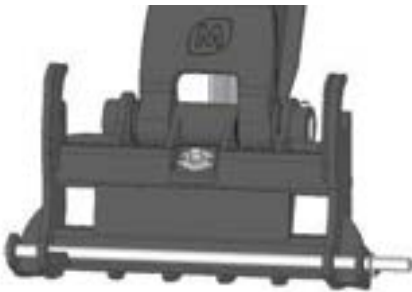

The “U” coupling is designed to be fitted with equipment designed and constructed by Magni Telescopic Handlers Srl with a similar coupling, just as it can also be fitted with equipment designed and constructed by other manufacturers (e.g. Manitou Costruzioni Industriali), subject to checking and approval of installation conformity by Magni Telescopic Handlers S.r.l.

OPERATING TECHNIQUES

Before using the vehicle

NOTICE

Take note of what is already contained in the "Correct Use" and "Reasonably Foreseeable Misuse" sections.



CAUTION

Operators using the vehicle must be trained and must be familiar with all its working aspects. The operator must obtain a licence or certificate if required by the regulatory standards in force. If the vehicle is used on public roads, a regular driving licence is required in accordance with the laws in force.

Always shut the cab door. Lock the windows and/or door open or closed. Clean all windows to ensure perfect visibility.

Check the condition of the seat belt and fixing points. Replace all visibly damaged and worn parts. Replace the entire safety belt after 3 years irrespective of wear. Do not use extensions.

Before starting the I.C. engine, check the level of all the fluids: engine oil, transmission oil, hydraulic fluid, coolant, fuel, urea (if present).

Check under the vehicle for oil, fuel or coolant leaks.

Make sure all the hoods are closed and all guards are installed correctly on the vehicle.

Adjust the seat so that the pedals can be pressed completely while sitting correctly. Adjust the steering column inclination to ensure a comfortable posture and easy access to all the controls.

Make sure the lighting on board is adequate for the working conditions, and that all the lights are working correctly.

Check to make sure the horn, signalling lights and all the alarm devices work correctly.

Adjust the orientation of the rear-view mirrors to best cover the visual area around the vehicle.

Check the state and wear of the tyres. If necessary, adjust the inflation pressure.

Work area



WARNING

Before each operational phase check that the ground where you are working is capable of supporting the weight of the vehicle and the maximum load-bearing capacity according to the equipment installed.



CAUTION

Check the specific manual of the interchangeable equipment in use for any special requirements.

Weather conditions

Always check the weather conditions before and during work phases: if visibility is poor, suspend work.

In the event of thunderstorms with lightning, suspend work.

Using the vehicle in windy conditions

The variation in wind speed can lead to many problems such as loss of vehicle stability, swinging load, reduced visibility due to rising earth, dust, leaves, etc.

Unfavourable factors for vehicle use are:

- Location of the site: the aerodynamic effect of buildings, trees and other structures can lead to an increase in wind speed.
- The height of the extended boom: the higher it extends vertically, the more the wind speed is perceived.
- The load area: the more area the load occupies, the more it is affected by the wind force.

Near gale

Magni telescopic handlers can be used up to a wind speed of 36 km/h equal to 10 m/s (5 on the Beaufort scale) measured on the ground.

Wind-Chill effect

At a temperature of 50°F (10°C), a wind speed of 32 km/h (8.9 m/s) makes the exposed parts of the body feel a temperature of 32°F (0°C).

The higher you climb, the more the wind speed increases and the more the feeling of a drop in temperature increases.



WARNING

In the presence of strong wind (5 on the Beaufort scale) never lift loads with a surface area of more than 1 m².

Below is a table of the Beaufort scale in order to be able to roughly determine the wind speed and assess the possible suspension of work

Climatic conditions of use

It is recommended to always take into account the climatic and atmospheric conditions of the place of vehicle use.

The vehicle is designed for use in different temperature, humidity and altitude conditions. However, it is still advisable to observe the values given in the technical tables (*Environmental Data*).

For use in extreme cold conditions, it is necessary to install a few additional devices to help with start-up (e.g. coolant, fuel, engine oil and/or hydraulic fluid heater, higher capacity batteries, etc.)

Contact your dealer or after-sales service for technical support in this regard.

Always take into account the climatic and atmospheric conditions of the place of use.

Using the vehicle in snowy conditions



WARNING

Be careful to use the vehicle and proceed with great caution in the event of snow falling and/or snow on the ground as it hides obstacles, buries objects, it can cover holes / excavations / ditches, etc.

It is strictly forbidden to operate if the amount of snow is such that the obstacles and dangers along the route cannot be clearly distinguished.

In case of snow be very careful not to move away from the roadside; anything buried along the edge of the road could cause the vehicle to overturn or damage some components.

Surfaces covered with snow or ice are extremely dangerous, operate with great caution and reduce the vehicle speed as much as possible.

In case of snow operate with great caution, if the vehicle sinks into the snow there is a risk that it may overturn or remain buried and/or trapped.

Be very careful when moving on icy ground; as the temperature increases, the base becomes loose and slippery.

BEAUFORT WIND SCALE					
force	speed (km/h)	speed (mi/h)	speed (m/s)	wind type	wind effects
0	0 - 1	0 - 1	> 0.3	calm	smoke rises vertically;
1	1 - 5	1 - 4	0.3 - 1.5	light air	wind causes smoke to drift;
2	6 - 11	5 - 7	1.6 - 3.3	light breeze	leaves rustle;
3	12 - 19	8 - 11	3.4 - 5.4	gentle breeze	leaves and twigs constantly agitated;
4	20 - 28	12 - 18	5.5 - 7.9	moderate breeze	the wind raises dust, dry leaves, small tree branches constantly moving;
5	29 - 38	19 - 24	8 - 10.7	fresh breeze	small trees in leaf begin to sway;
6	39 - 49	25 - 31	10.8 - 13.8	strong breeze	large branches constantly moving, hissing between the telegraph wires;
7	50 - 61	32 - 38	13.9 - 17.1	near gale	entire trees moving, difficulty in walking against the wind;
8	62 - 74	39 - 46	17.2 - 20.7	gale	broken branches, walking against the wind is impossible;
9	75 - 88	47 - 54	20.8 - 24.4	strong gale	shingles and tiles blown away;
10	89 - 102	55 - 63	24.5 - 28.4	storm	seldom experienced on land, trees uprooted, considerable damage to dwellings;
11	103 - 117	64 - 73	28.5 - 32.6	violent storm	rare, severe devastation;
12	beyond 118	74 +	32.7 +	hurricane	destruction of buildings, constructions etc.;

Road circulation



WARNING

Check, before proceeding on public roads open to traffic, that the vehicle is properly approved for the country in which it is to be used.

The circulation on the road with accessory mounted in the head of the boom is allowed only if expressly indicated in the technical attachment of the road approval.

Contact Magi Telescopic Handlers Service for more information.



WARNING

In the event of regular type approval, check that the vehicle in use has all the specifications set out in the relevant registration certificate and is operated in accordance with the prescriptions therein.

While travelling on roads, only use the mode with two steering wheels.

Travel with the telescopic boom completely retracted and lowered as far as possible.

Make sure that the quick-fit coupling is high enough from the ground.

Parking the vehicle

Always park the vehicle on a flat surface.

Always apply the parking brake.

Set the reversing switch to neutral N,

Position the vehicle on stabilisers or, when on wheels, place suitable wheel chocks.

Switch the engine off.

Do not leave loads suspended.

Do not park the vehicle with a load hanging from the equipment.

If the vehicle is to remain parked for a long period, protect it from atmospheric agents.

Before stopping the engine let it run at minimum for a few minutes. Immediately stopping the engine after it has been working under load can cause overheating and premature wear of some of the components.

Retract the telescopic boom and lower it.

Before leaving the vehicle, check all the locks:

- engine compartment;
- fuel cap;
- cab door;
- additional lockable equipment.

For long-term stops, turn the battery cut-off switch in the engine compartment to switch off the main circuit. This will prevent a short circuit and damage to the batteries and will preserve the charge from abnormal power draws.

NOTICE

For engines meeting Stage V anti-pollution standards, wait at least 5 minutes after the engine is switched off before disconnecting the main electrical circuit.

This compliance preserves the after-treatment system operating with the urea-based additive (AdBlue®).

Install a waterproof covering to protect the vehicle from atmospheric agents if it is to remain unused for a long period.

Interchangeable equipment installation



WARNING

If fitted incorrectly, an attachment can suddenly detach from the vehicle during operation. This can cause injury or even death.

Do not operate the vehicle without the shear pin fitted in the quick-fit coupling.

Position the attachment on a stable level surface. Make sure there is sufficient space for operation. Check the attachment to make sure it is clean and intact before fitting it.

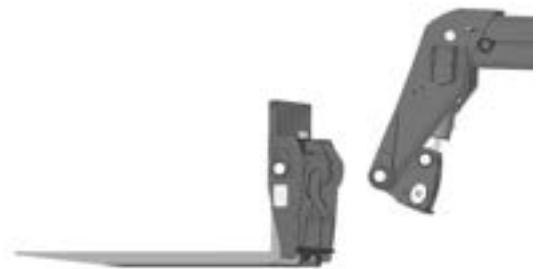

Bring the vehicle perpendicular to the equipment with the boom completely retracted and lowered. Retract the slewing cylinder to make hooking easier. Stop the vehicle with the quick-fit coupling about a metre away from the equipment. Move the reverse gear lever to the neutral position and apply the parking brake.



Extend the telescopic boom slowly, checking the alignment until the quick-fit coupling is engaged, then raise it to fit the accessory. Raise the equipment by a few centimetres off the ground to ensure the elements fit in perfectly.



Rotate the quick-fit coupling until fully coupled with the accessory.

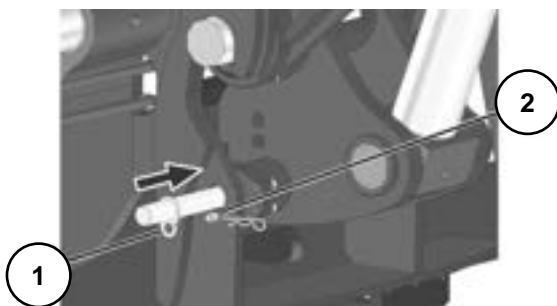

Take the shear pin ① from its housing on the vehicle chassis and insert it in all the way, taking care to align the hole. Complete the procedure by inserting the cotter pin ② in the hole to prevent the shear pin from coming loose accidentally.



DANGER

It is forbidden to operate without the locking pin secured with interchangeable equipment installed.



DANGER

In the event of problems during coupling due to deformations of the equipment structures or the shear pin, it is strictly forbidden to proceed with the use of the vehicle and the equipment itself until the problem is resolved.

In the case of interchangeable equipment requiring hydraulic and/or electrical functions, connect the respective connectors to those at the head of the telescopic boom.



WARNING

The hydraulic connections are marked with metal labels: respect the couplings. Incorrect coupling can cause malfunctioning of the equipment by reversing the commands given.

Equipment confirmation

Magni Telescopic Handlers are equipped with an RFID (Radio Frequency Identification) equipment recognition sensor installed in the centre of the quick-fit coupling: this system allows the vehicle's software to recognise, at the instant of coupling, the type and model of equipment present at the head of the boom.

Correct recognition enables in-cab a specific load diagram with relevant working areas and operating limits.

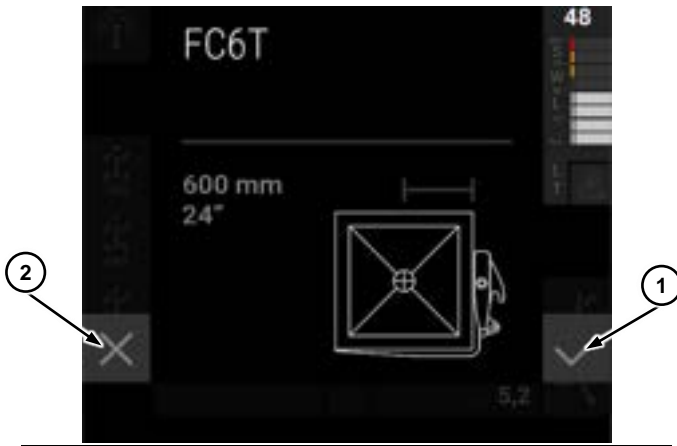

Confirmation of the equipment is done via a request on the display by means of an active banner: the example above shows the recognition of a fork attachment plate with a capacity of 6t; if the equipment on the boom head is correct, the pairing must be confirmed by pressing button ① ✓.

CAUTION

In the event of non-recognition or incorrect recognition, press button ② X: in this condition the vehicle is operational with limited functions (NO TOOLS) for the handling of unrecognised equipment in the construction site area only.

Check the condition of the RFID sensor at the head of the boom and the respective tag mounted on the unrecognised equipment.

DANGER

It is strictly forbidden to work with equipment that is not recognised by the vehicle software while operating with the limit disabling key active.

Removing the equipment

Position the vehicle on a stable level surface. Make sure there is sufficient space for operation. Move the reverse gear lever to the neutral position and apply the parking brake.

Remove the cotter pin and remove the shear pin. Fit the shear pin in its housing on the vehicle chassis.

Lower the telescopic boom and rest the equipment gently on the ground. Rotate the quick-fit coupling downwards to make it easy to detach the equipment.

Lower the telescopic boom to separate the slewing variable-reach truck from the accessory. Retract the

boom completely to separate the quick-fit coupling from the equipment.

Clean the equipment thoroughly. Grease all the pins and movable parts to protect them from corrosion and wear. Remove excess grease to prevent accumulation of dirt.

Always keep the equipment protected from atmospheric agents. Rest the equipment on a support raised off the ground and protect it with a waterproof cover if necessary.

Hydraulic shear pin

With this configuration, a hydraulic jack inside the quick-fit coupling locks the interchangeable equipment. This operation can be managed from the cab without getting off for manual safety pin insertion.

For vehicles equipped with hydraulic safety pin, regardless of “I” or “U” model, a specific actuation button with dedicated graphics is available on the dashboard to the right of the seat.



To lock the equipment, when quick-fit coupling and interchangeable equipment have been correctly coupled, press the dedicated button on the dashboard and operate the joystick hydraulic command by rotating the roller forward.

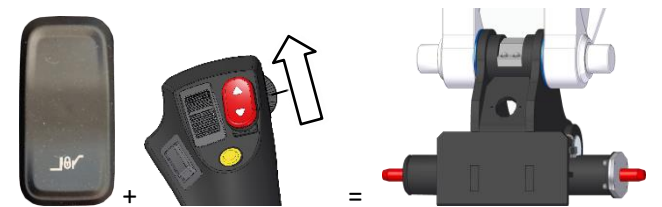

Pin open → equipment locked

To unlock the equipment, press the dedicated button on the dashboard and operate the joystick hydraulic command by rotating the roller backward.

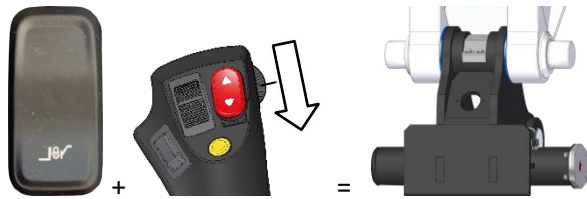

Pin closed → equipment unlocked

List of compatible accessories

- Winch
- Bucket (e.g. for concrete)
- Jib
- Lattice boom with winch
- Hook
- Waste buckets
- People carrier aerial work platform
- Clamp (with different applications)
- Fork attachment plate
- Branch cutter

These accessories are approved for use on the telescopic handler models mentioned in this manual. Do not use accessories that are not approved by the manufacturer. Contact your dealer for more information on approved accessories.

NOTICE

The list of compatible equipment is subject to change without notice.

Approved equipment



WARNING

The use of interchangeable equipment not approved on the vehicle by Magni Telescopic Handlers S.r.l. may result in injury or death.

Before installing interchangeable equipment on the vehicle, make sure it has been approved by Magni Telescopic Handlers S.r.l., and that the corresponding load charts are present in the vehicle management software.

The code of the interchangeable equipment manufactured by Magni Telescopic Handlers S.r.l. is stamped on its identification plate. To establish whether interchangeable equipment is approved, contact the dealer or the Support Service directly.

Some interchangeable equipment produced by companies other than Magni Telescopic Handlers S.r.l. can be adapted for fitting on the vehicles described in this Manual. Contact your dealer to know if your interchangeable equipment can be adapted for assembly on your vehicle.

If the interchangeable equipment is suitable and before proceeding, the equipment and the vehicle must be sent to the dealer for the required modifications and tests. A document confirming proof of the combination will be issued at the end of the procedure.



CAUTION

It is forbidden to use interchangeable equipment without the EC Declaration of Conformity and the Use and Maintenance Manual. It is also forbidden to use any interchangeable equipment on your vehicle if the EC Declaration of Conformity does not confirm its compatibility.

Handling of loads

During load handling operations always display the load control page to keep the percentage indicator and load chart under control.



DANGER

If the load status indicator is in alarm, make only the unloading movements in the following order:

- retract the telescopic boom as far as possible;
- lift the telescopic boom if necessary;
- lower the boom to deposit the load.
- never try to extend the telescopic boom when the load indicator shows an alarm signal.

Centre of gravity of the load

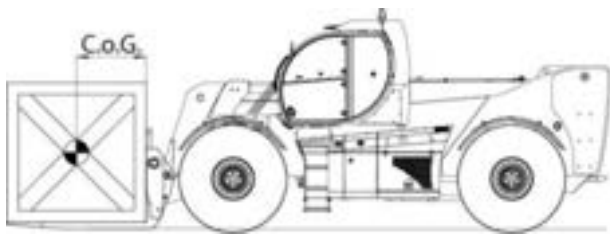

Never try to lift loads heavier than the rated capacity of the vehicle.

Before lifting a load, it is necessary to know its weight and the relative centre of gravity position. The longitudinal position of the centre of gravity varies according to the type of interchangeable equipment attached to the vehicle.

Refer to the technical specifications in the interchangeable equipment's user manual to know the centre of gravity used.

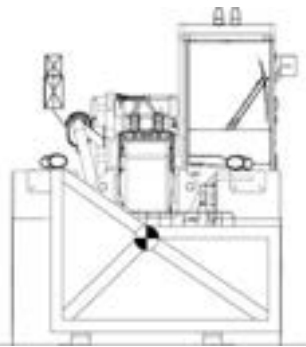

In case of irregular loads, determine the centre of gravity in the transverse direction to the vehicle before making any movement.

For loads with mobile centre of gravity, such as tanks containing liquids, it is necessary to take into account

the load oscillations and take utmost caution in handling to avoid excessive shifting of the centre of gravity.

Picking up a load from the ground with fork attachment plate



DANGER

During manual adjustment of the forks or other parts of the interchangeable equipment there is a crushing hazard for the limbs. This can lead to serious injuries.

Take the utmost care while handling the load.

Position the vehicle perpendicular to the designated load.

Manually adjust the width of the forks so that these can be inserted in the openings in the pallet at the base of the load. If there is no pallet, assess the width of the blades to give the load maximum stability.

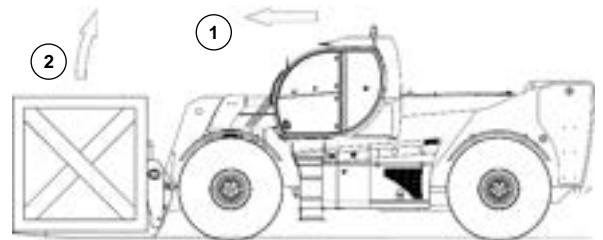

Incline the quick-fit coupling ① so that the forks are not in the horizontal position. Approach the load ② slowly with the boom lowered and insert the forks under it.

Apply the parking brake and set the reverse gear lever in the neutral position.

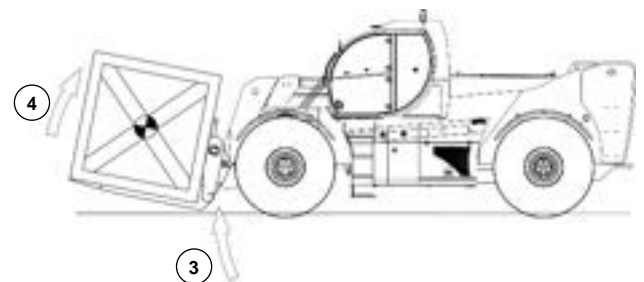

Lift the load slightly ③ and incline the quick-fit coupling upwards ④ to make the load stable. Take care to avoid modifying the load balance negatively (tipping forward).

Taking a load from a height with the vehicle on tyres with fork attachment plate

Put the vehicle perpendicular to the designated load. Make sure the forks pass under the load and are properly adjusted to the load.

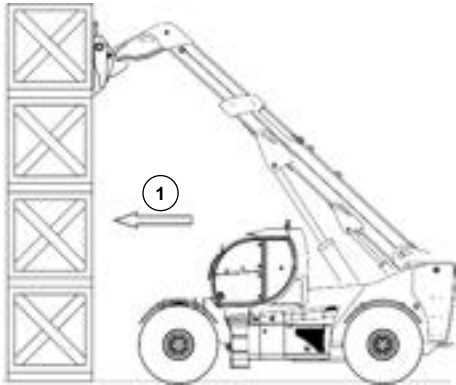

Bring the vehicle near the load **1** slowly with the forks in the horizontal position. Move carefully to insert the forks under the load.

The forks must enter the pockets of the pallet all the way with precision. Take care to avoid knocking against the load.

Apply the parking brake and set the reverse gear lever in the neutral position.

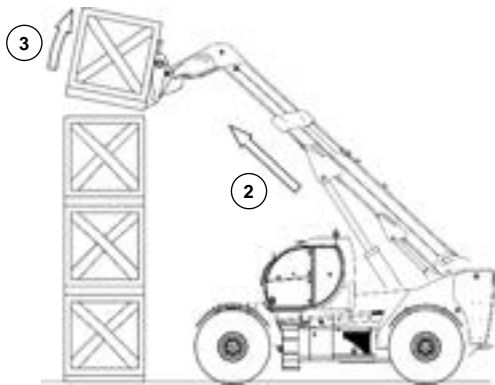

Lift the load **2** slightly and incline the quick-fit coupling upwards **3** to make the load stable, taking care to avoid modifying the balance negatively.

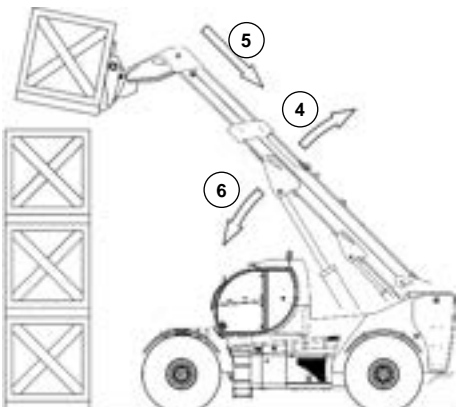

If possible, lower the load without moving the slewing variable-reach truck. Lift the boom to move the load away **4**, retract the telescopic boom **5** and lower it to bring the load to the transport position **6**.

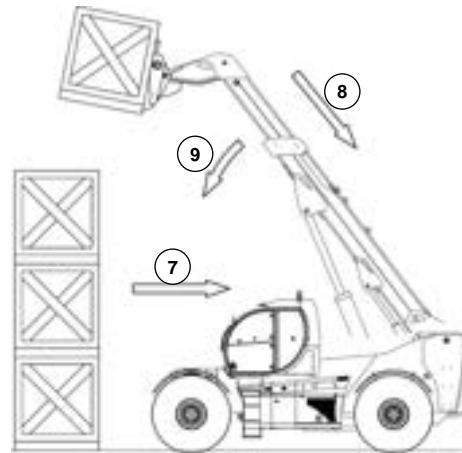

If the load cannot be lowered without shifting the vehicle, move gently in reverse **7** and with utmost care to move the load away. Retract the telescopic boom **8** and lower it **9** to bring the load to the transport position.

Bring the load to the transport position

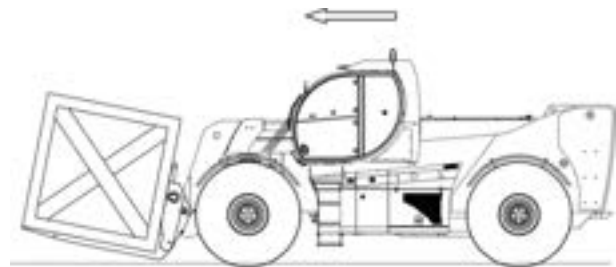

Every time reference is made to the “transport position” in this Manual, it means the configuration of the vehicle is as described below:

- Outriggers lifted;
- Telescopic boom completely retracted;
- Quick-fit coupling rotated slightly upwards;
- Telescopic boom lowered in such a way as to keep the load approx. 300 mm off the ground.

For specific cases, the transport configuration is indicated in the “Pick & Carry” chart in the relevant section of the interchangeable equipment’s Use and Maintenance Manual.

Placing a load at a height with the vehicle on tyres

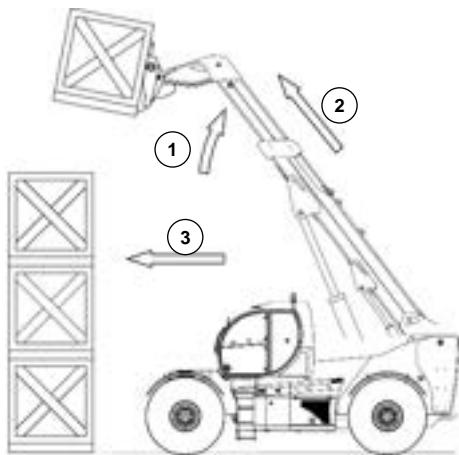

After picking up the load, lift ① and extend ② the telescopic boom to position the load above the area in which it is to be deposited. Move the telescopic handler close to the area where it is to be deposited ③.

Apply the parking brake and set the reverse gear lever in the neutral position.

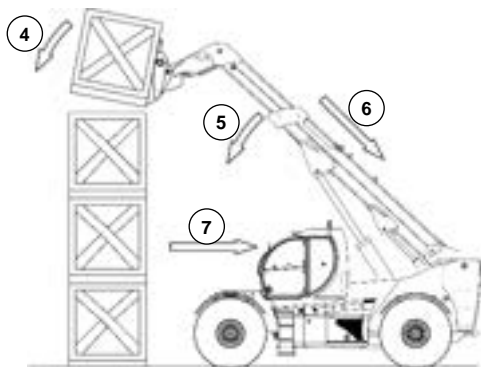

Rotate the quick-fit coupling downwards ④ to position the load horizontally. Lower ⑤ and retract ⑥ the boom with slow movements to release the load in its place.

Release the parking brake and set the reverse gear lever in reverse. Release the forks lowering the telescopic boom slightly and moving slowly in reverse ⑦.

Picking up a cylindrical load without pallet with fork attachment plate

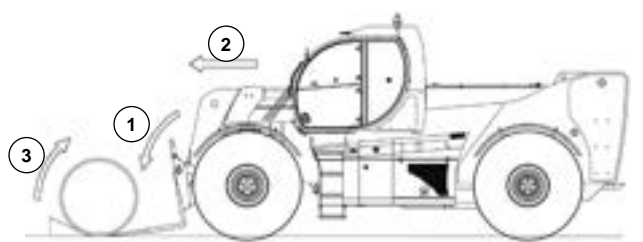

Position the vehicle at right angles to the load. Approach the load with the telescopic boom completely lowered and retracted. Apply the parking brake and set the reverse gear lever in neutral. Incline the quick-fit coupling downwards ①. Extend the telescopic boom slowly ② and at the same time rotate the quick-fit coupling upwards to insert the forks under the load ③.

If the operation is found to be difficult, insert a chock behind the load, to prevent it from shifting while the forks are being inserted.

Moving the centre of gravity

Before picking up a load, it is necessary to know its mass and centre of gravity.

The position of the centre of gravity is indicated on the dimensional drawings and on the load charts in the Use and Maintenance Manuals of the individual accessories.

During operation, the slewing variable-reach truck is subjected to a number of stresses that can affect its stability and therefore its safety.

The objective of greater operational safety is achieved by complying with the balancing principle, which entails operating without compromising the longitudinal and transverse balance of the slewing variable-reach truck, in order to prevent the causes that may cause it to overturn.

For loads with a movable centre of gravity (e.g. liquids), possible variations in the centre of gravity must be taken into account to determine the load volume to be handled.



DANGER

It is forbidden to handle a load exceeding the actual capacity specified on the corresponding load chart in the Use and Maintenance Manual of the individual accessory used.

Operate with the utmost caution and care to limit such variations as much as possible.

Visibility

When driving the vehicle, it is mandatory to remain particularly vigilant especially in its immediate vicinity due to the possible presence of people, animals, obstacles, etc.

Here are a few useful recommendations to have, and maintain, good visibility around the vehicle:

- Make sure you always have a good view from the cab (clean windows, sufficient lighting, rear view mirror adjusted, etc.).
- Always try to have a good view of the route, with direct vision and indirect vision (using the panoramic rear view mirrors) to check for the possible presence of people, animals, holes, obstacles, changes in slope, etc.
- Visibility, on the right side, may be reduced when raising the boom, so make sure you have a good view of the route before raising the boom and proceeding with operations.
- If visibility while driving is insufficient, ask for the support of a person on the ground to provide signals
- The slewing variable-reach truck's signalling systems and lights must be suitable for its conditions of use. The vehicle's standard lighting might not be enough for use in environments that are poorly lit or at night.

Traversing over sloping ground



WARNING

Working with the vehicle on sloping ground can cause overturning or slipping. Move forward and brake gently taking the necessary precautions.

Always move in a straight line to climb up or down a slope.

Always use the parking brake when placing or lifting a load on a slope.



DANGER

Do not move crosswise or horizontally along the slope: risk of tipping over.

When travelling on sloping routes, whether uphill or downhill, turn the lifting accessory downstream for empty movements and upstream for movements with a load.

It is strictly forbidden to move with the load facing downstream on a downhill slope, because it would seriously compromise the stability of the load and the slewing variable-reach truck.

If you must go down the slope with a load, do so in reverse gear with the load positioned upstream.

If you must go up the slope with a load, do so in forward gear with the load positioned upstream.

Please contact your dealer or the Magni Telescopic Handlers Service Department for technical support.

INFORMATION REGARDING TRANSPORT

Shipping the vehicle

Make sure the total weight of the vehicle and transport vehicle comply with the standards and regulations in force in the countries along the route.

Ensure that the road chosen has vertical and horizontal margins suitable for the transport vehicle with the vehicle loaded on it.

Before loading the vehicle, remove all slippery material from the transport vehicle, railway carriage or loading ramp.

Before loading the vehicle, always block the wheels of the transport vehicle or railway carriage with chocks.

The boom must be completely retracted and lowered, until the quick-fit coupling or equipment come to rest on the transport vehicle.

The dimensions and weights for shipping a standard vehicle are shown in this Use and Maintenance Manual in the technical specifications.

Lifting the vehicle



DANGER

Always check the condition of lifting elements such as ropes and chains.

Check that the lifting equipment has adequate capacity to lift the vehicle.

The weight and dimensions of the vehicle can be found in the specific section *“Technical Data”*

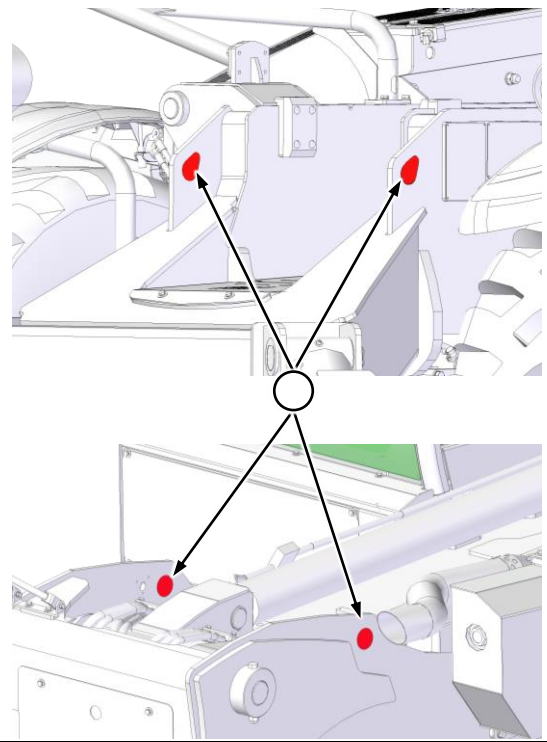
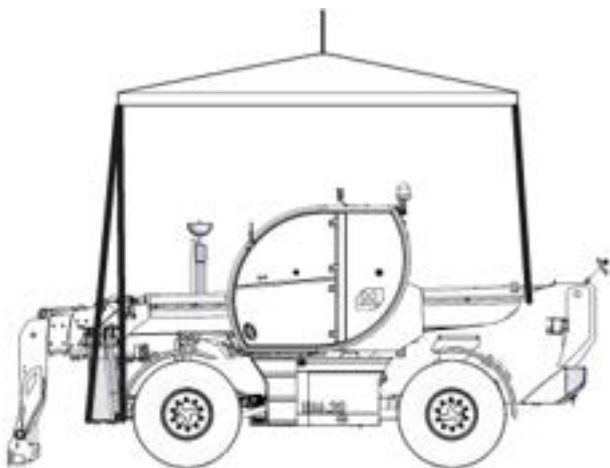

The configuration of the lifting devices must be such as to avoid damage to the vehicle. Insert the lifting hooks into the points ① (front) and ② (rear) as indicated above. The four designated points are marked with the following symbol.

NOTICE

These instructions are referred to on the vehicle with a special warning sticker placed on all stabilisers.

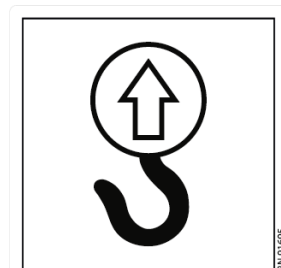

Anchoring the vehicle for transportation



DANGER

Always check the condition of anchoring elements such as ropes and chains.

Check that the transport equipment has adequate capacity to transport the vehicle.

The weight and dimensions of the vehicle can be found in the specific section "Technical Data".

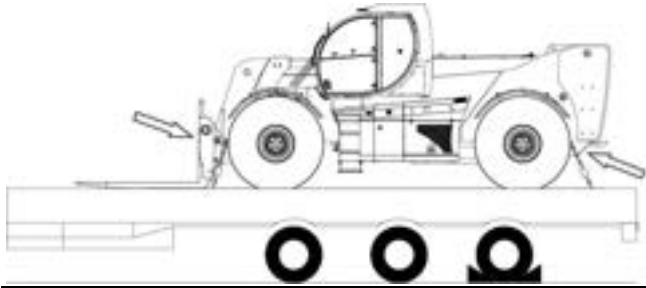

Install anchoring devices approved for the weight of the vehicle with equipment. Fix the anchoring devices at the four points indicated.

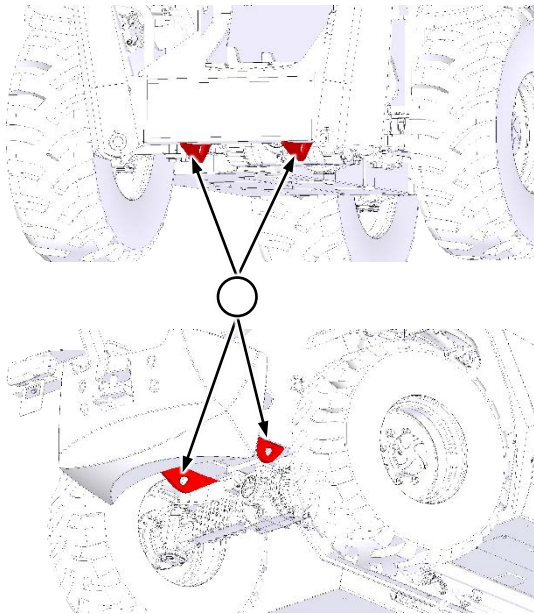

Block the front and rear wheels of the vehicle with chocks. Insert the wedges from both sides of each tyre.

Apply the parking brake and set the reverse gear lever in neutral.

Make sure the boom is completely retracted. Make sure the boom is lowered and the equipment rests on the surface of the transport vehicle.

Stop the engine and remove the ignition key from the switch. Get out of the vehicle and close all windows, doors and compartments.

If in doubt, contact your dealer for information and assistance.

NOTICE

The vehicle's anchorage points are marked on the vehicle by special warning stickers.

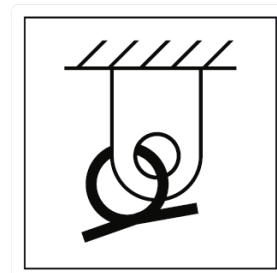

Towing the vehicle



DANGER

Towing the vehicle is a very delicate manoeuvre that can create high risks for the operators involved in the operation.

We recommend performing repairs on site.



WARNING

Towing the vehicle with an incorrect procedure can cause accidents, even very serious ones.

Follow the instructions given below to tow the vehicle correctly.

Before disengaging the negative brake manually, block the vehicle to prevent its movement.

Tow a vehicle only for short distances and in any case not exceeding 1640 ft (500 m) at speed not higher than 3.1 mph (5 km/h). If the vehicle is to be transported for longer distances and at higher speeds, use a suitable transport vehicle.

Before towing the vehicle, retract and lower the telescopic boom completely and remove the load.

Do not use chains or cables for towing the vehicle.

It is mandatory to tow the vehicle using a rigid towing bar compatible with the mass to be towed.

Make sure the rigid towing bar is in good condition and has a nominal carrying capacity 1.5 times the weight of the vehicle to be towed.

Switch on the hazard lights.

Mechanical brake release

Below are the instructions for mechanical release of the braking system following a hydraulic fault.



WARNING

Before carrying out any operation on brake release, it is mandatory to place chocks under the vehicle's wheels to prevent its accidental movements.

Go under the vehicle near the front axle. Completely loosen the lock nut ① then screw in the adjusting screw ② fully home to disengage the negative control brake. Repeat the procedure on all the four screws on the axle.

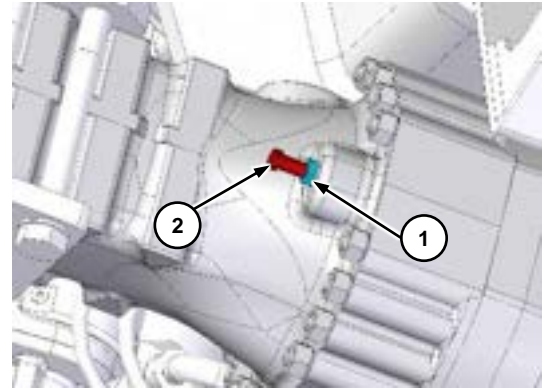

DANGER

When this operation has been carried out, the machine is no longer braked.

Pay attention!

Manual positioning of the reverse gear in neutral

Below are the instructions for mechanical release of the reverse gear following a hydraulic fault.



WARNING

Before putting the gear into Neutral, it is mandatory to place chocks under the vehicle's wheels to prevent their accidental movements.

Move under the vehicle near the front axle from the right side of the cardan shaft.

Identify the hydrostatic transmission and hydraulic actuator of the reverse gear ①.

Disconnect the fittings ② and ③ from the actuator and plug the end of the pipes with two suitably sized screw caps.

Move the rod of the actuator ① using a tool, and insert it into the proper slot to gain leverage.

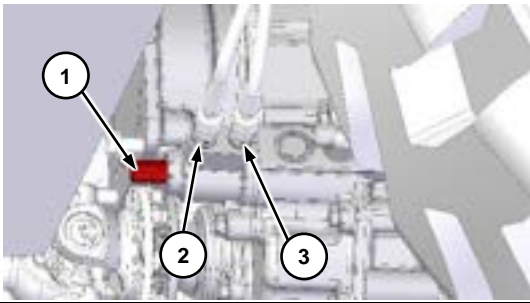

You will hear a click when moving from fully open to fully closed: this position identifies the engagement of the reverse gear in Neutral.

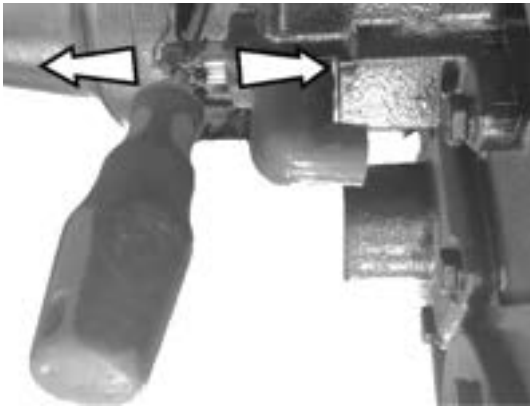

DANGER

When this operation has been carried out, the transmission is disengaged.

Pay attention!

MAINTENANCE

General information

Vehicle in maintenance position

Before carrying out any maintenance operations, follow the instructions below:

- Park the vehicle on level, non-yielding ground.
- Apply the parking brake.
- Remove connected equipment and handling loads.
- Lower and retract the telescopic boom.
- If it is necessary to work with the boom raised, secure it with suitable securing systems.
- Switch off the engine and remove the ignition key from the control panel.
- Disconnect the electrical circuit by means of the battery cut-off switch.
- Let all thermal components cool down
- Apply the "Maintenance in progress" sign.

Tightening torques



CAUTION

Unsuitable bolts or those of incorrect size can cause damage, faults and injuries.

Take care to avoid mixing metric nuts and bolts with nuts and bolts in inches.

The tightening torques shown in the following tables are meant as general reference. Exceptions are indicated on a case by case basis.

Before fitting any component, make sure it is as good as new. Bolts and threads must not be worn or damaged. The threads must not have burrs or be chipped.

The components must not be rusty or corroded. Clean the components with a non corrosive detergent. Do not grease the threads of the bolts unless otherwise specified.

Metric nuts and bolts

Size	Tightening torque		
	8.8	10.9	12.9
M5	6 Nm	8,5 Nm	10 Nm
M6	10 Nm	14 Nm	17 Nm
M8	25 Nm	35 Nm	41 Nm
M10	49 Nm	69 Nm	83 Nm
M12	86 Nm	120 Nm	145 Nm
M14	135 Nm	190 Nm	230 Nm
M16	210 Nm	295 Nm	355 Nm
M20	410 Nm	580 Nm	690 Nm
M22	550 Nm	780 Nm	930 Nm
M24	710 Nm	1000 Nm	1200 Nm
M27	1050 Nm	1500 Nm	1800 Nm
M30	1450 Nm	2000 Nm	2400 Nm
M33	1950 Nm	2700 Nm	3300 Nm
M36	2500 Nm	3500 Nm	4200 Nm



WARNING

In particular conditions that involve repeated replacement of screws and/or bolts, check the state of the threads with special "go - no- go" pads.

Pipe clamps

For first assembly on a new pipe:

Width	Tightening torque
0.31 in (7.9 mm)	0.9 ± 0.2 Nm
0.53 in (13.5 mm)	4.5 ± 0.5 Nm
0.62 in (15.9 mm)	7.5 ± 0.5 Nm

For a second assembly:

Width	Tightening torque
0.31 in (7.9 mm)	0.7 ± 0.2 Nm
0.53 in (13.5 mm)	3.0 ± 0.5 Nm
0.62 in (15.9 mm)	4.5 ± 0.5 Nm

Tyres

NOTICE

Only use tyres approved by Magni Telescopic Handlers S.r.l.



CAUTION

Use a quick-fit coupling and keep behind the tread when inflating the tyres.

Appropriate equipment and training are necessary to avoid excessive inflation.

Inadequate procedures can cause a tyre to burst or breakage of a rim.

Before inflating a tyre, install it on the vehicle or on a device to hold it steady.

Standard inflation pressures

The inflation pressures given in the Technical Product Information section are those for cold inflation and standard shipment of MAGNI vehicles, and may vary depending on the conditions of use. For more information, contact the tyres supplier.

Do not fill tyres with foam. Tyres filled with foam can damage certain components of the vehicle. Using tyres filled with foam can invalidate the warranty.

Sealing liquid can be inserted into the tyres, if the maximum weight of the vehicle is not exceeded. If the maximum weight of the vehicle is exceeded the warranty and the certification of certain components and structures may be cancelled.

Tyres inflated in the workshop (approx. 64.4°F (18°C) to 70°F (21°C)) will be deflated if the vehicle works at temperatures below zero. Adjust the pressure of the tyres in case of environmental temperatures less than 32°F (0°C).



CAUTION

Periodically check that the inflation value is correct, also according to sensitive climatic variations and/or working environments, as given in this manual, on the sticker applied near each wheel under the mudguard or, if it is missing, contact Magni Telescopic Handlers S.r.l. Support Service.

Inflation with air

Adjust the tyre inflation apparatus regulator to not more than 0.5 bar more than the inflation pressure.

NOTICE

In case of doubt regarding the inflation pressure for fitted tyres, contact your dealer.

Inflation with nitrogen



WARNING

Special equipment and training are necessary for inflating tyres with nitrogen. Non-conforming procedures can lead to bursting of a tyre or breakage of a rim, with serious consequences, sometimes even mortal.

The pressure inside a filled nitrogen cylinder is about 150 bar. If not used correctly, the inflation equipment can explode causing serious injuries or even death.

It is advisable to use dry nitrogen for inflating tyres and adjusting pressures. Nitrogen is an inert gas and reduces risk of explosion.

Nitrogen reduces rusting of the wheel, deterioration, and rusting of the rims. Adjust the tyre inflation apparatus regulator to not more than 1.4 bar more than the inflation pressure. Use the same inflation pressure as that with air.

Replacing the wheels

NOTICE

Only use tyres approved by Magni Telescopic Handlers.



CAUTION

Make sure that the surface of the work area is compact and of sufficient consistency to withstand the load placed on it.

If working in an area with loose soil, place plates under the handlers and winch supports to prevent them from sinking.

Park the vehicle on a flat surface, apply the parking brake, to change wheels on the front axle lower the stabilisers to lift it off the ground and turn the engine off.

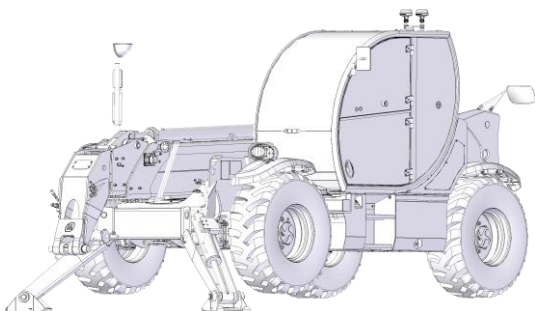

When changing wheels on the rear axle, use a lifting jack and secure the vehicle on suitable stands adequately dimensioned for the load to be borne

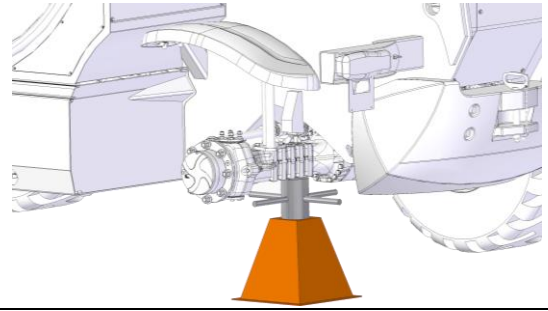

With the vehicle raised, remove the nuts and replace the affected wheel.



WARNING

Movement or falling of the vehicle placed on winch supports can result in serious injury or even death.



WARNING

Pay the utmost attention to movement of the wheel after unfastening the nuts: accidental falling of the wheel can cause serious injuries to the person carrying out this maintenance.

To facilitate handling and replacement, we recommend the use of a slewing variable-reach truck (or one equipped with a wheel clamp) to support the weight of the wheel and prevent it from accidentally falling off the axle.

Refasten the nuts removed earlier and tighten them in a criss-cross pattern using the tightening torque indicated in this manual and marked on the vehicle near the axles.

When done, lift the vehicle off the winch support, remove it and lower the vehicle to the ground.

Washing



CAUTION

When cleaning the vehicle, avoid the direct use of high-pressure water jets on all visible main electrical and hydraulic elements. (E.g. under the cab, on the telescopic boom head, inside the rear cab compartment, on the back of the vehicle, on the valve transducers and on all microswitches in general, etc.).



Liquids, lubricants and spare parts

List of liquids and lubricants recommended for routine maintenance

Compartment	Type	Strength	Operating temperature (min/max)	Quantity
<i>Cooling circuit</i>	List of liquids recommended by DEUTZ specifications "DQC CA-14"	50%/50%*	-41.8°F -41°C	5.28 U.S. gal 20 l
		35%/65%*	-7.6°F -22°C	
<i>Fuel tank</i>	Diesel			52.8 U.S. gal 200 l
<i>AdBlue® tank (only for D7 engines [Stage V])</i>	AdBlue®	ISO 22241-1		2.65 U.S. gal 10 l
<i>Engine sump</i>	Recommended oil list according to DEUTZ specification "DQC III LA" / "DCQ IV LA"	SAE 5W30	-16.6°F/+86°F -27°C/+30°C	2.37 U.S. gal 9 l
		SAE 10W40	-4°F/+104°F -20°C/+40°C	
<i>Front axle gear</i>	Oil	SAE 85W90	-4°F/170.6°F -27°C/+77°C	0.74 U.S. gal 2.8 l
<i>Front/rear axles differentials</i>	Oil	SAE 85W90	-4°F/170.6°F -27°C/+77°C	2.9 U.S. gal 11 l
<i>Wheel reduction gears</i>	Oil	SAE 85W90	-4°F/170.6°F -27°C/+77°C	0.42 U.S. gal 1.6 l
<i>Hydraulic fluid tank</i>	Oil	ISO 46	5°F/266°F -15°C/+130°C	23.7 U.S. gal 90 l
<i>Greasing points</i>	Grease	NGLI 2	-22°F/248°F -30°C/+120°C	as requ.
<i>Boom sliding</i>	Grease	PTFE NLGI 2	-4°F/+302°F -20°C/+150°C	as requ.

* The percentages correspond, in the order, to the composition of the antifreeze+distilled water mixture:

- 50%/50% means a mixture in equal parts;

- 35%/65% corresponds to a mixture of 35% antifreeze and 65% distilled water.

List of spare parts for routine maintenance

<i>Type of spare part</i>	<i>Description</i>	<i>Quantity</i>	<i>Magni Code</i>	
			<i>Stage IIIA</i>	<i>Stage V</i>
<i>External cab air filter</i>	Filter cartridge	1		09371
<i>Internal cab air filter</i>	Filter cartridge	1		88120
<i>Engine air filter</i>	Primary filter cartridge	1		79919
<i>Engine air filter</i>	Safety filter cartridge	1		79920
<i>Hydraulic fluid tank bleed</i>	Bleed cap	1		31480
<i>Alternator drive belt</i>	Belt	1		77450
<i>Water drive belt</i>	Belt	1		77449
<i>Compressor transmission belt</i>	Belt	1		87333*
<i>Fuel filter</i>	Filter cartridge	1		24309
<i>Fuel pre-filter</i>	Filter cartridge	1		24293
<i>Engine oil filter</i>	Filter cartridge	1		24289
<i>AdBlue pump filter</i>	Filter cartridge	1	/	33204**
<i>AdBlue tank filter</i>	Filter cartridge	1	/	99018**
<i>Hydraulic transmission fluid filter (delivery/suction)</i>	Filter cartridge	1		23094

* Only for models with air conditioning kit installed.

** Only for Stage V engines equipped with SCR catalytic converter.

NOTE: Always check the codes of listed spare parts with your Magni Telescopic Handlers dealer.

Maintenance Schedule



CAUTION

Read and understand all the warnings and instructions before starting any maintenance operation.

Before carrying out any maintenance operation, make sure all the scheduled actions have been carried out as planned.

In cases where the vehicle operates in particularly harsh environmental conditions (e.g.: quarries, desert areas, dusty and / or sandy areas) plan to halve the maintenance intervals indicated below.

As required

Transmission belt - replacement
 AdBlue® filter
 Fuel tank - refuelling
 Windscreen washer liquid tank – filling

Every 10 hours of operation or daily

Engine oil - check
 Coolant - check
 Telescopic boom sliding blocks – check
 Liquid leaks – check
 Emergency hydraulic pump - operation test
 Wheels - check the tyre pressure

Every 50 hours of operation or every 2 weeks

Transmission shaft –
 lubrication of universal joints
 Hydraulic fluid – check
 Telescopic boom sliding blocks – lubrication
 Telescopic boom pins – lubrication
 Fuel prefilter – discharge water
 Wheels – check tightness of nuts

Every 250 hours of operation or every 3 months

Transmission belt - check
 Differentials oil - check
 Two-speed reduction gear oil – check
 Wheel reduction gear oil – check
 Steering elements – lubrication

Every 500 hours of operation or every 6 months

Hydraulic fluid filter – replacement (suction)
 Hydraulic fluid filter – replacement (drainage)
 Engine oil and filter – replacement
 Engine radiator – cleaning
 Engine pipes - inspection

Every 1000 hours of operation or every year

Fuel filter – replacement
 AdBlue® filter – replacement
 Air filter – replacement of primary cartridge
 Fuel prefilter – replacement
 Differentials oil - change
 Two-speed reduction gear oil – change
 Wheel reduction gears oil – change
 Telescopic boom sliding blocks – adjust the play
 Fuel tank – clean

Every 1500 hours of operation

Fuel filter –
 clean mesh element
 Fuel prefilter – replacement

Every 2000 hours of operation or every 2 years

Hydraulic fluid – change
 Air filter – replacement of safety cartridge
 Coolant - change

Maintenance operations

Safety information

Before carrying out any maintenance, please read the Safety and Warnings section in this manual in detail.

A summary of the symbols used with a brief description is given again:



GENERIC DANGER



DANGER OF BURNS



DANGER OF CRUSHING



DANGER FROM HANGING LOAD



ELECTRICITY



RISK OF INTOXICATION



BATTERIES



FLAMMABLE MATERIAL



PRESSURISED FLUIDS



MOVING PARTS



RISK OF SLIPPING



RISK OF FALLING, TRIPPING



NO SMOKING OR LIGHTING UP ANY KIND OF NAKED FLAME

All maintenance must be carried out by personnel who have been instructed, trained and have the necessary technical skills to work safely.



DANGER

Maintenance carried out by untrained operators without the appropriate technical skills can lead to serious health risks and even death.

Battery disconnect switch

Before starting any maintenance operations, switch the engine off and disconnect electric voltage by turning the battery disconnect switch in the engine compartment.

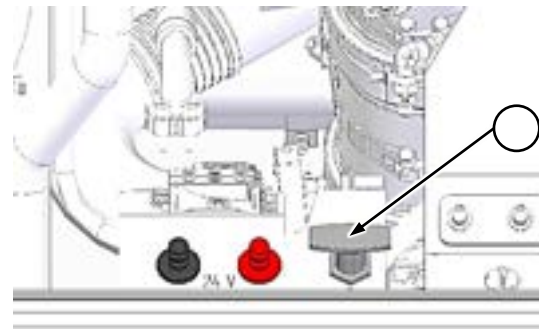

Maintenance operations under the telescopic boom

The vehicle is equipped with a mechanical safety device (yellow) to be applied to the lifting cylinder rod that prevents its closing if maintenance needs to be carried out under the telescopic boom.

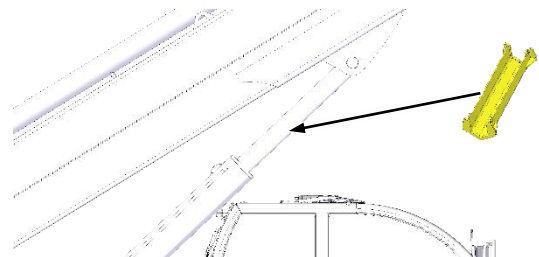

It is also possible to secure the telescopic boom to the overhead crane using the 4 eyebolts on its structure.

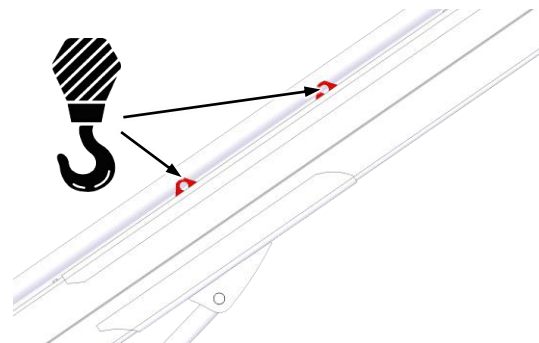

Maintenance operations in areas not accessible from the ground

For maintenance on areas/parts of the vehicle that are not accessible from the ground, it is recommended not to climb on it but to use alternative systems such as ladders with platforms (EN 131-7)



DANGER

The maintenance item carried out on areas/parts of the vehicle that are not accessible from the ground without the use of appropriate safety devices and equipment can lead to serious health risks and even death.

Hydraulic hoses

Inspection

Check the condition of the hydraulic hoses on the vehicle for a visual inspection and ensure that there are no leaks from the connectors ①, fittings ② or along the hose ③.

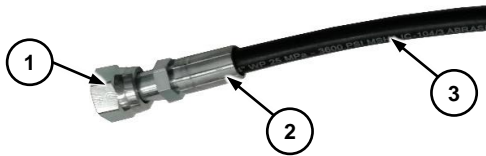

If a fault is found in any of the points indicated above, replace the hose and check the condition of the seals on the part the hose screws onto (connector, valve, hose).

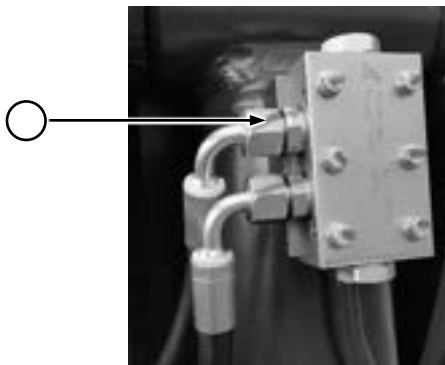

Differentials oil

Maintenance for the axle differentials (front and rear) is as follows.

Check every 500 hours

Set the vehicle on a flat surface in the parking position. Make sure no one approaches the work area.

Go to the front axle.

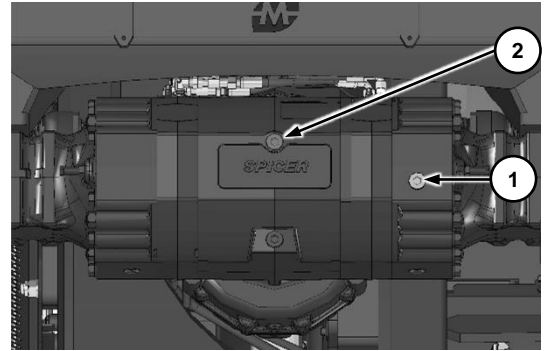

Remove the level plug ①. The oil must flow out through the opening.

If necessary, remove the filler cap ②. Add oil to the correct level. Close level cap ①, and then filler cap ②. Clean the axle surfaces.

Replacement every 1000 hours

Set the vehicle on a flat surface in the parking position. Make sure no one approaches the work area.

Place suitably sized containers under the front axle.

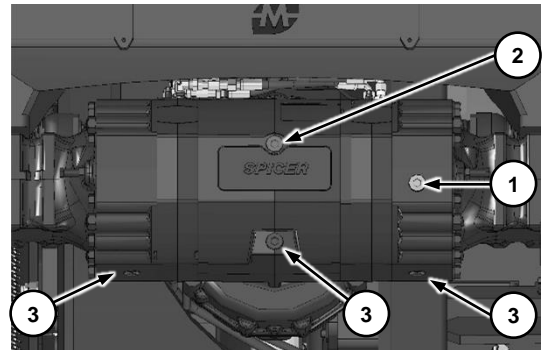

Remove the three drainage caps of the differential ③. Wait for the oil to drain completely out of the differential. To speed up the operation, remove filler cap ②.



WARNING

Do not dispose of used oil in the environment but take it to the appropriate storage and disposal sites.

Refit caps ③ and tighten adequately. Remove the level plug ①.

Pour fresh oil of the correct type (refer to the Liquids and Lubricants table in this manual) through hole ②. Fill in stages and check the flow of oil through level hole ①.

When the correct level is reached, refit level cap ① and filler cap ②.

Repeat the above operations for the rear axle too.

Wheel reduction gears oil

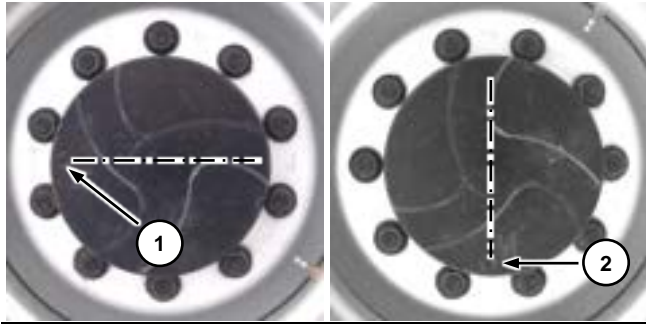

Check every 250 hours

Set the vehicle on a flat surface in the parking position. Turn the reduction gear cap in the horizontal position ①. Remove the cap. The oil level is correct when the oil flows out through the filler hole. If necessary, top up with oil to the correct level. Refit the cap. Repeat this operation for each wheel.

Replacement every 1000 hours

Set the vehicle on a flat surface in the parking position. Place a suitably sized container under the reduction gear. Turn the reduction gear cap in position ②. Remove the cap and wait for the oil to drain out completely.

Turn the reduction gear cap in position ①.

Pour oil through the hole to the correct level.

Refit the cap.

Repeat this operation for each wheel.



WARNING

Do not dispose of used oil in the environment but take it to the appropriate storage and disposal sites.

Transmission shaft

Lubrication of universal joints

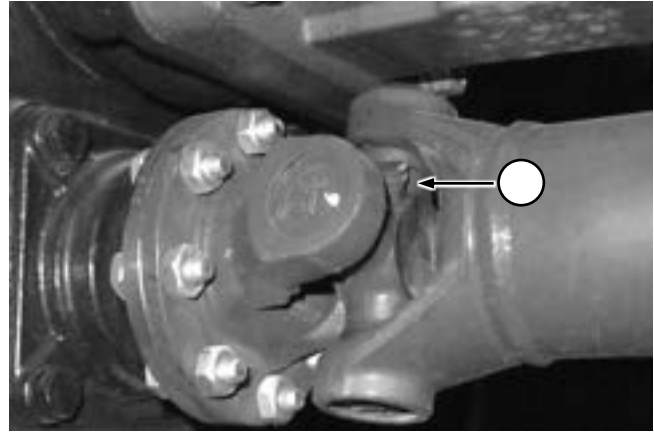

Set the vehicle on a flat surface in the parking position. Make sure no one approaches the work area. Lubricate the universal joints by injecting grease into the grease nipples. Repeat for all the transmission shaft joints. Remove the excess grease.

Steering elements

Lubrication

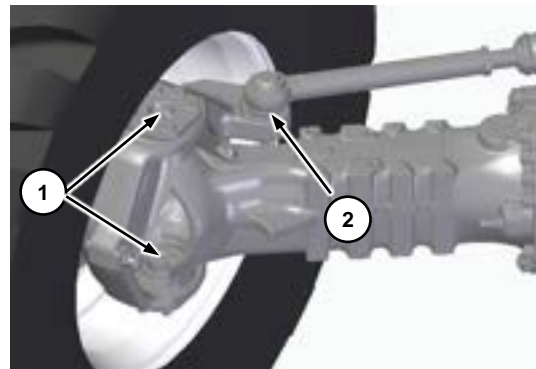

Lubricate the wheels rotation pins ① by injecting grease in the grease nipples provided for the purpose. Remove the excess grease. Lubricate the ball joint ② injecting grease in the grease nipples provided for the purpose. Remove the excess grease.

Repeat the operations for each wheel.

Axles

Lubrication of oscillation bushes



Set the vehicle in the parking position. Make sure no one approaches the work area. Stand near the front axle oscillation bushes. Inject grease in the grease nipples present on both sides of the axle (front and rear).

Repeat the lubrication for the rear axle.

Transmission belt



CAUTION

Work on the transmission belt only with the engine stopped! After repairs, make sure all the protection devices have been refitted and that no tool has been forgotten on the engine.

Checking the belt tension

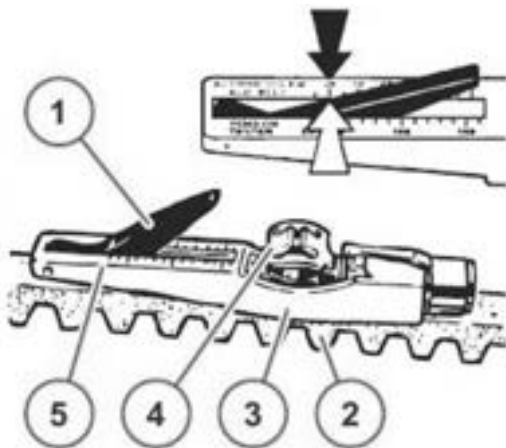

To check the tension of the belts, lower the boom of indicator ① in the tester.

Place the guide ③ between two pulleys on the V-belt ②. At this point, the stop must be on the side.

Press button ④ in the right corner with respect to V-belt ② uniformly until the spring clicks audibly.

Lift the tester gently, without modifying the position of the indicator arm ①.

Read the value measured on the intersection point (arrow), scale ⑤ and indicator arm ①.

Correct the tension if necessary and repeat the measurement.

The belt tension tester can be ordered through the Customer Service.

Replacement

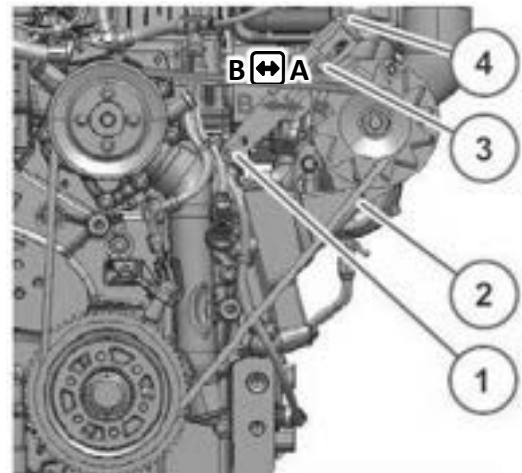

① screw - ② screw - ③ screw - ④ adjuster wrench.

To replace the transmission belt: unscrew the screw and lock nut, move the generator above the adjuster wrench in direction (B) until the belt slackens, remove the belts and fit the new ones, reposition the generator above the adjuster wrench in direction (A) until the belt tension is correct, check the belt tension:

- pre-tensioning 650 ± 50 Nm
- correct tension 400 ± 50 Nm

tighten the screw and lock nut.

Tightening torque:	screw (1)	30 Nm
	screw (2)	42 Nm
	screw (3)	30 Nm

Engine oil



WARNING

Do not operate with the engine running!

Do not smoke or use naked flames!

Danger of burns!



Replace every 500 hours.

During operations on the lubricant oil system, ensure utmost cleanliness. Thoroughly clean the area around the components involved from time to time.

Dry the damp parts with air jets. For handling lubricant oils follow the safety directives and specific local standards.

Dispose of the leaked lubricant oil and the filter elements. Do not let the used lubricant oil spread in the ground. Run a test cycle after every intervention.

At the same time, ensure sealing and pressure of the lubricant oil and then check its level.

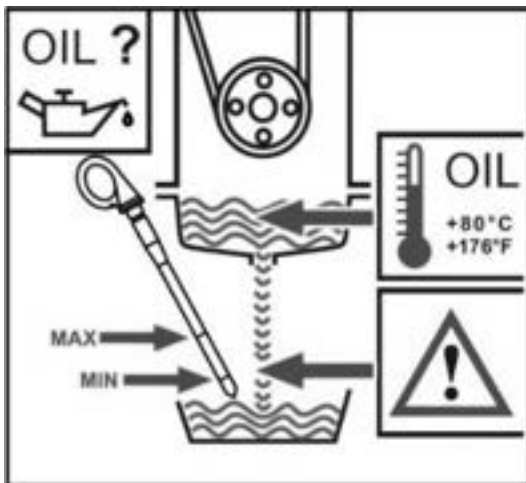

An insufficient and/or excessive lubricant oil level can damage the engine. Check the oil level only with the engine horizontal and stopped. Check the lubricant oil level only while it is warm, 5 minutes after the engine is switched off. Do not remove the oil level rod with the engine running. Danger of burns.

Checking the engine oil level

Remove the rod and wipe it clean with a cloth, do not leave fibres.

Insert the oil rod up to the stop then remove it and read the lubricant oil level.

The level must always be between the MIN and MAX notches. Top up to the MAX notch if necessary.

Changing the engine oil

Replace every 500 hours or at the same time as engine oil replacement.

Heat the engine until the oil temperature reaches $> 176^{\circ}\text{F}$ (80°C).

Park the vehicle on a horizontal surface and stop the engine.

Place a container under the drain screw, unscrew the latter and drain out the lubricant oil.



WARNING

Do not dispose of used oil in the environment, but take it to the appropriate storage and disposal sites.

After draining, reposition the screw with a new sealing ring and tighten by applying a 55 Nm torque.

Pour lubricant oil, warm the engine to a temperature $> 176^{\circ}\text{F}$ (80°C) and check the lubricant oil level.

Top up, if necessary.

Replacing the lubrication oil cartridge



Loosen the filter using the tool and unscrew it.

Collect the lubricant oil that flows out.

Wipe the surface of the filter-holder with a clean cloth that does not leave lint.

Oil the original DEUTZ filter cartridge seal slightly.

Manually screw the new filter tightening it by applying a 10-12 Nm torque.

Fuel prefilter



WARNING



FLAMMABLE MATERIAL

Fuel is flammable and can cause severe burns and death.

Do not smoke or use naked flames while working on the fuel line.

Clean the engine parts and engine compartment to remove all traces of fuel to prevent risk of fire.

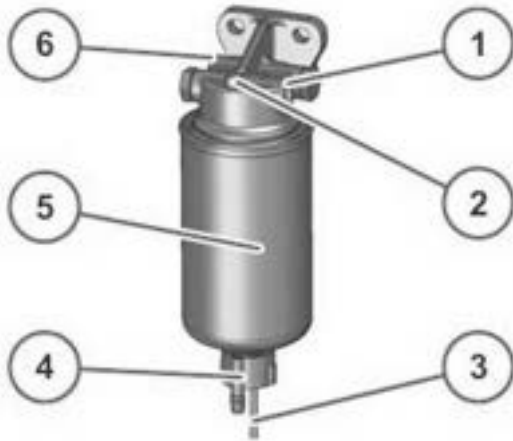

① pump fuel supply - ② bleed screw - ③ electric connection for the water level sensor - ④ drainage cap - ⑤ filter cartridge - ⑥ fuel tank inlet

Replace every 1000 hours

Emptying the water container

Stop the engine.

Place a suitable container.

Electrical connection.

Disconnect the cables.

Loosen the drainage screw.

Drain the liquid until the pure diesel fuel starts flowing out.

Fit the drainage cap by applying a tightening torque of 1.6 ± 0.3 Nm.

Connect the cables.

Replacing the fuel filter cartridge

Stop the engine.

Block the fuel intake to the engine (if the tank is positioned at the top).

Place a suitable container.

Electrical connection.

Disconnect the cables.

Unscrew the drainage cap and drain out the liquid.

Remove the filter element.

Wipe the surface of the new filter cartridge and the opposite side of the filter head to remove dirt.

Slightly dampen the surfaces of the filter cartridge with fuel and re-screw the filter head clockwise (17-18 Nm).

Fit the drainage cap by applying a tightening torque of 1.6 ± 0.3 Nm.

Connect the cables.

Open the fuel cock and bleed the system (see "Bleeding the fuel system").

Fuel filter

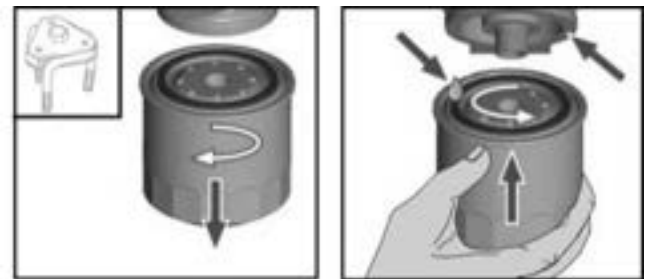
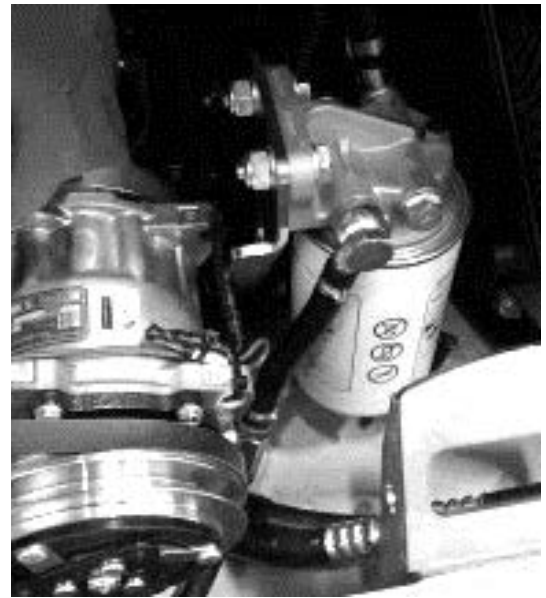

Replace every 1000 hours

Loosen the filter using the tool and unscrew it.

Collect the fuel that flows out.

Wipe the surface of the filter-holder with a clean cloth that does not leave lint.

Oil the original DEUTZ filter cartridge seal slightly.

Manually screw the new filter tight.

Tighten the clamps of the anti-twisting safety (optional).

Bleed the fuel supply system.

Bleed the fuel supply system

The fuel supply system is bled by means of the fuel delivery electric pump.

To make sure fault messages are not generated, try not to start up during the bleeding process.

This process is carried out as follows.

Switched on.

The fuel delivery electronic pump is activated for 20 seconds to bleed the fuel supply system and generate the necessary fuel pressure. Wait for the fuel delivery electric pump to be deactivated from the control unit.

Switched off.

Repeat the process at least twice until the fuel supply system bleeding is complete.

AdBlue® filter



RISK OF INTOXICATION

The ammonia in AdBlue® is highly toxic and corrosive, and in contact with tissues can cause serious burns or even death.

Wear protective clothing and goggles to avoid contact with the tissues. In case of contact with tissues, rinse thoroughly with plenty of water and get medical care.

Before working on the AdBlue® supply system, read the safety information given in the section "information regarding AdBlue®".

Replacement

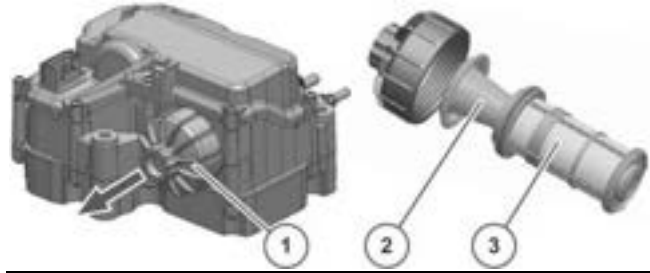

① cover, ② compensator, ③ filter cartridge.

Replace every 1000 hours

Proceed with replacement of the filter cartridge of the AdBlue® supply pump by following the indications given:

- switch the engine off,
- disconnect the electric terminals,
- place a suitably sized container under the pump and filter to hold the liquid flowing out,
- remove the cover using a 27 mm hex head wrench,
- remove the compensator and filter element completely,
- replace the filter element and refit it together with the compensator,
- fit the cover by applying a 22 ± 2.5 Nm tightening torque,
- reconnect the electrical system,
- start the engine.

NOTICE

For drive units satisfying the Stage V anti-pollution standards, in order to protect the AdBlue® purification system, wait at least 5 minutes after the I.C. engine is switched off, before acting on the main electric circuit to disconnect it.

Fuel tank

Refuelling

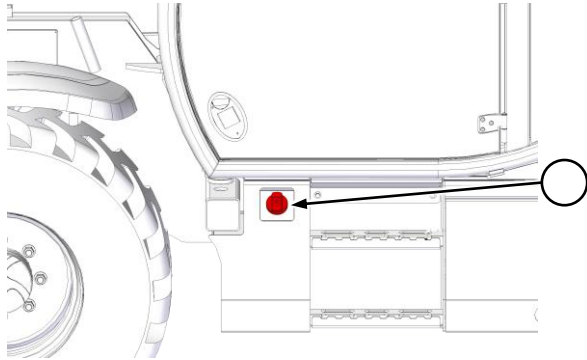

Set the vehicle in the parking position. Switch the engine off.

Unlock the fuel filler cap located on the left side of the vehicle slewing variable-reach truck, using the appropriate key. Unscrew the tank cap by turning it anticlockwise.

Refuel using suitable fuel. Screw the fuel cap in and lock using a wrench.



CAUTION

For drive units complying to Stage V regulatory standards use only fuels with low sulphur content, as indicated on the label positioned on the side of the tank filler opening.

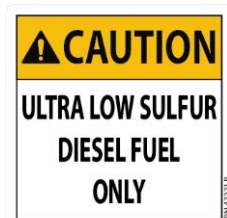

Cleaning

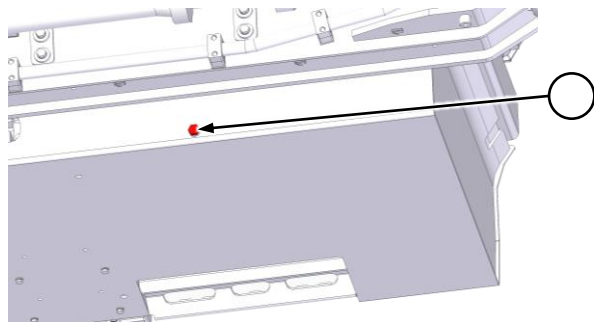

To facilitate the operation, park the vehicle on a flat surface and switch it off.

Place a suitable sized container under the fuel tank near drainage cap, then remove the filler cap

Unscrew the drainage cap and drain out the tank completely.

Pour 10 litres of clean fuel into the tank to rinse out impurities that may be present at the bottom by draining it out.

Close and tighten the drainage cap. Fill the tank with clean fuel. Check to make sure there are no leaks.

Coolant



WARNING

The coolant is pressurised and at high temperature with the engine switched on. When the cap is removed, the liquid may flow out violently and cause serious burns.

Make sure the engine is cold before working on the cooling system

Inspection

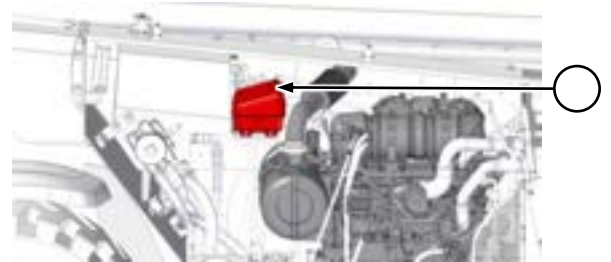

Set the vehicle in the parking position.

Check the level in the expansion tank placed inside the engine compartment. The level is correct when it is half-way on the inspection window.

Open the tank, check the coolant additive concentration ratio using the instrument concerned (e.g. hydrometer, refractometer)

If necessary, top up with a suitable mixture depending on the use.

Refit the cap and make sure it is tightened properly. Run the engine to bring it to the required temperature. Switch off the engine and check for leaks in the circuit.

Bleeding the cooling system

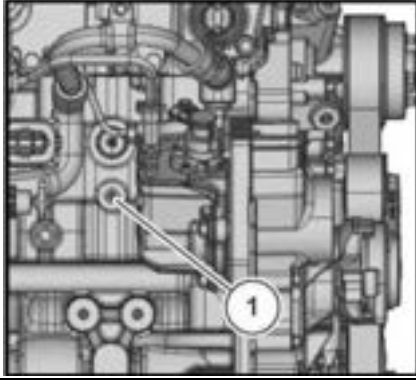

Replace the coolant every 2 years to eliminate any corrosion of cooling components.

Set the vehicle in the parking position.

Remove the radiator cap carefully to release the residual pressure.

Place a suitably sized container under the drainage cap to collect the coolant flowing out.

Remove screw **1** and drain out the coolant. If the screw is not accessible, drain through the engine oil radiator (coolant duct).

Refit the screw by applying mastic.

Refit the radiator cap.

Engine radiator

Cleaning

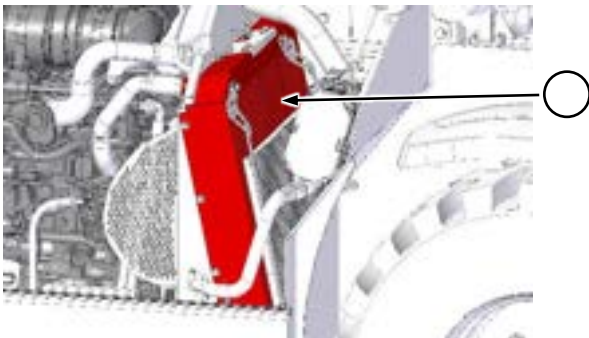

To remove dust and debris from the radiator mass, compressed air, pressurised water or steam can be used. However, it is preferable to use compressed air.

NOTICE

When using pressurised water, keep the high pressure jet cleaning nozzles at a distance of at least 19,7 in (50 cm) from the radiator mass. Bringing the nozzle too close to the radiator mass can lead to risk of damaging the radiator.

Hydraulic fluid

Inspection

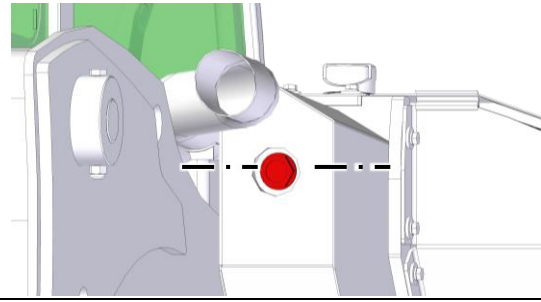

The hydraulic fluid tank is on the rear left side of the vehicle. Check the hydraulic fluid level through the inspection window present on the tank.

The oil level is correct if it is halfway on the window, as shown by the dashes in the figure.

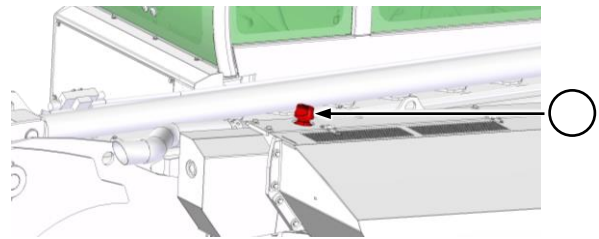

If necessary, add oil by accessing the cap at the top of the tank. Pour oil of suitable strength up to the correct level. Refit the cap and tighten it manually.

Replacement

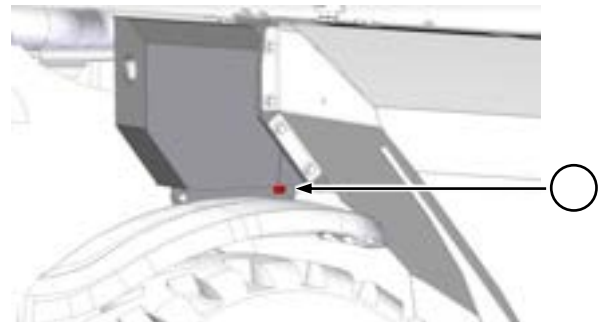

To facilitate the operation, park the vehicle on a flat surface and switch it off.

Place a suitably sized container under the bleed valve **1**. Unscrew the cap and drain out the oil. To speed up the operation, also unscrew the filler cap.

Refit drainage cap **1**, and fill the tank with fresh fluid. Close the filler cap.

Start the engine. Check to make sure there is space to extend the telescopic boom completely. Raise and lower the boom a number of times. Extend and retract the boom a number of times.

With the boom in the transport position, drive the vehicle carefully forwards. Steer the vehicle to the right and left.

Park the vehicle and check the oil level. Add oil if necessary.

Hydraulic fluid filter



CAUTION

The vehicles use a single filter for hydraulic fluid: the filter placed on the inside of the hydraulic tank has the combined function for oil at the suction as well as return.

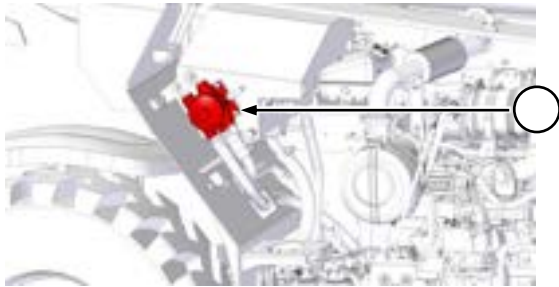

The hydraulic fluid filter is located inside the engine compartment; park the vehicle on level ground and switch off the engine; open the bonnet and clean the filter housing and surrounding areas to prevent dirt from entering the circuit. Unscrew the cap.

Replacement of the filter cartridge does not necessary involve drainage of the tank: the filter housing has a special closure system. When it is being removed, the oil present inside the filter normally flows out.

Remove the filter cartridge and dispose of according to the regulatory standards in force. Insert a new filter cartridge of the same type.

Refit the filter cover. Start up the engine and check for leaks.

Check for a drop in the oil level through the window present on the tank: if required, top up with the quantity necessary to reach the correct level.

Two-speed reduction gear oil

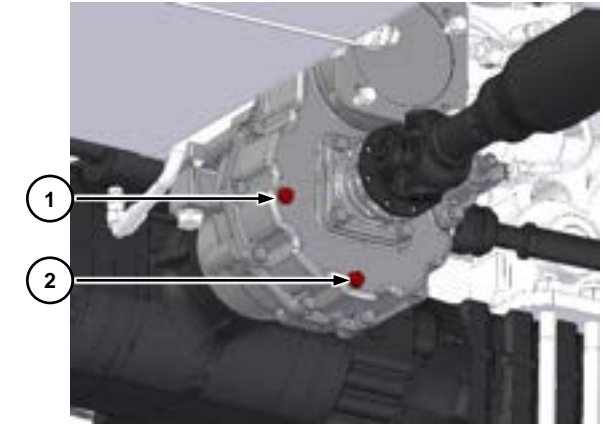

Inspection

Set the vehicle in the parking position. Make sure no one approaches the work area.

Remove the cap ①. Check the oil level: the level is correct if it reaches the base of the hole. Add oil if necessary.

Refit and tighten cap ①.

Replacement

Place a suitably sized container under the two-speed reduction gear.

Remove the cap ①. Remove the magnetic drainage cap ②. Wait for the oil to drain out completely.

Clean the magnetic cap ② to remove iron filings, then refit and tighten it.

Fill the reduction gear with oil through hole ① up to the prescribed level. Refit and tighten cap ①.

Engine air filter

The efficiency and life of the engine depend greatly on the quality of air taken in. A dirty or damaged air filter can seriously affect the correct working of the engine and increase the possibility of a failure.

Replace the air filters strictly according to the schedule indicated in this Manual. Do not try to wash dirty filters.

If the vehicle is expected to be used in environments with a lot of dust or high concentrations of contaminating or polluting agents in the air, halve the time interval between one filter replacement and the next.

Replacing the primary cartridge

To access the filter box, open the engine compartment and locate the air filter cartridge, which is on the right as shown in the image.

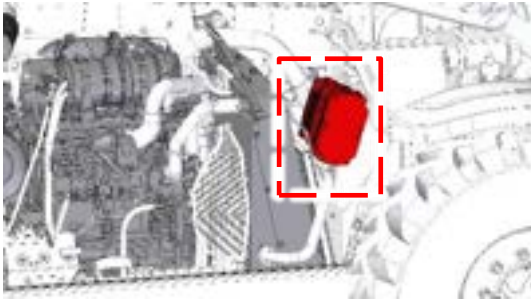

Release the 4 cover retainers and loosen the sleeve closing clamp underneath to facilitate removal and remove the front filter cover.

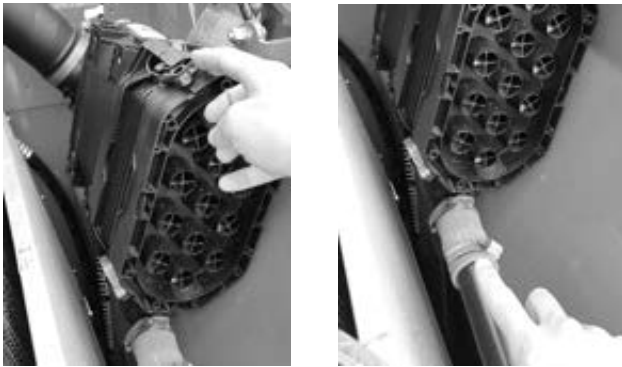

Grip the filter housing and remove it from its seat.



Wipe thoroughly inside the filter housing with a damp cloth. Avoid the use of aggressive solvents or products as these can damage the safety filter or the filter housing.

Install a new filter element. Make sure the filter element is inserted properly in its seat. If installation is difficult, grease the rubber gasket slightly with silicone grease.

Replacing the safety cartridge

Carry out the primary filter removal procedure described earlier.



Hold the filter element with two fingers in the holes and pull to separate it from its seat.

Wipe thoroughly inside the filter housing with a damp cloth. Avoid the use of aggressive solvents or chemicals as they can damage safety of the filter housing.

Install a new filter element. Lightly grease the outer gasket of the new filter element with silicone grease.

Cab air filter

Replacement

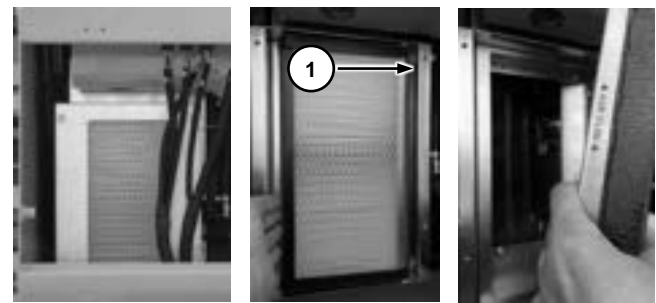

Open the compartment in the rear part of the cab to access the filter housing.

Unscrew the four screws ① and remove the filter holder frame.

Remove the air filter and replace it with a new one of the same type.

For reassembly repeat the above operations in reverse order. Check the correct direction of assembly before fitting the holder frame.

Telescopic boom sliding blocks

Inspection

Set the vehicle in the parking position. Extend the telescopic boom completely.

Check to make sure the boom movement is smooth. Ensure that there are no abnormal vibrations, unusual noises, and no part of the boom gets heated due to friction during the movement.

Check for the presence of a sufficient layer of grease on the sliding surfaces and on the sliding blocks.

Lubrication

Position the vehicle on a flat surface in a large enough area. Put the telescopic boom in the horizontal position and extend it fully.

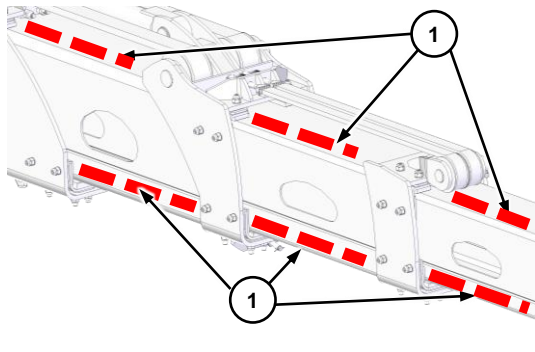

Thoroughly clean all the sliding surfaces ① in contact with the sliding blocks.

Using a brush or roller, apply a thin layer of grease on the sliding surfaces of the sliding blocks ① on all four sides of the extensions. Repeat this operation for each extension.

Retract and extend the telescopic boom a number of times to distribute the grease uniformly.

Remove excess grease to prevent accumulation of dirt.

Adjusting the play

Position the vehicle on a flat surface in a large enough area. Remove any equipment from the quick-fit coupling and move the telescopic boom into the horizontal position. Retract the telescopic boom almost completely.

Move to the front of the boom, and identify the sliding blocks as shown below.

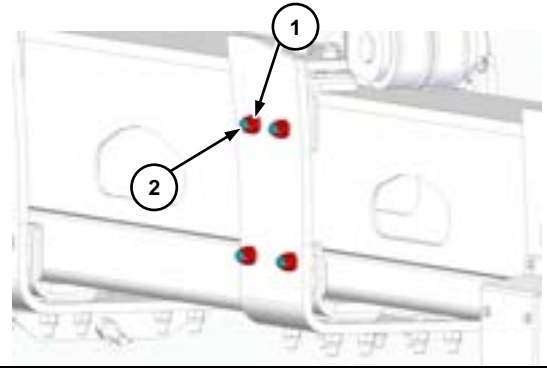

Loosen the lock nuts ① of the upper and side sliding blocks at the top of the boom. Screw all the grub screws ② all the way without tightening them, then unscrew them all by half a turn.

Repeat the adjustment operation for the lower and side sliding blocks at the bottom of the boom.

Tighten each lock nut holding the relative screw firm. Tightening torque: **100 Nm**.

Try to adjust the sliding blocks in such a way that all the screws ② protrude to the same extent.

Always try to adjust the sliding blocks symmetrically, to facilitate boom extension centring.

After completing the operations try to extend and retract the boom to check the boom movement is smooth.

If the movement of the boom is not smooth, repeat the adjustments, unscrewing the screws ② by one complete turn instead of by half a turn.

Contact your dealer for any clarification or for assistance if the sliding blocks are worn and need to be replaced.

Telescopic boom pins

Lubricate the pins of the movable parts of the telescopic boom at regular intervals. Lack of lubrication can cause seizure of the pins in their seats.

Wipe excess grease to prevent accumulation of dirt.

Lubrication of boom pin

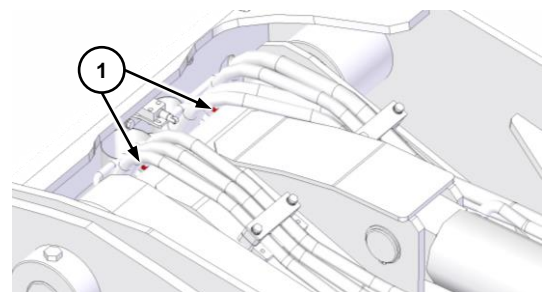

Lubricate the hinge pin by injecting grease in both grease nipples ① present on the telescopic boom.

Lubrication of lift cylinder pins

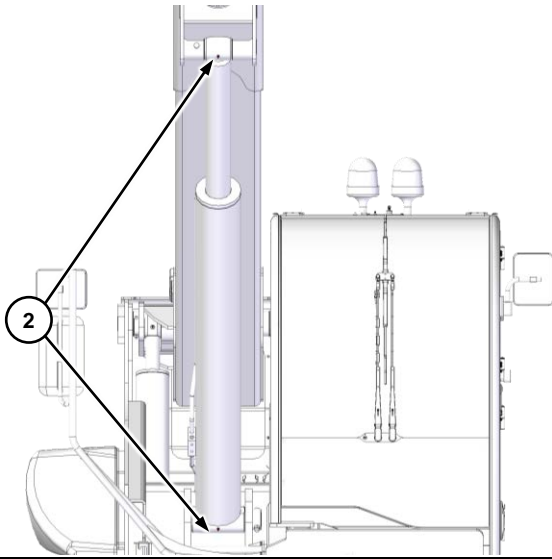

Lubricate pins ② of the lift cylinder. To make access to the grease nipples easier, lift the telescopic boom completely.

Lubrication of compensation cylinder pins

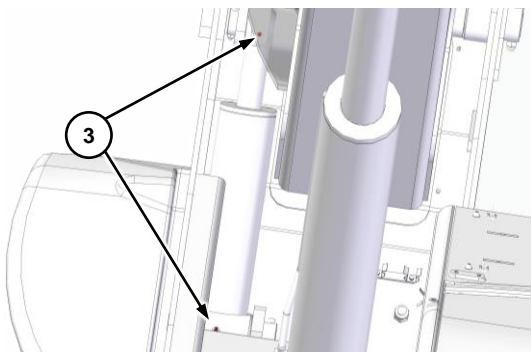

Lubricate pins ③ of the compensation cylinder. To make access to the grease nipples easier, lift the telescopic boom completely.

Lubrication of quick-fit coupling pin

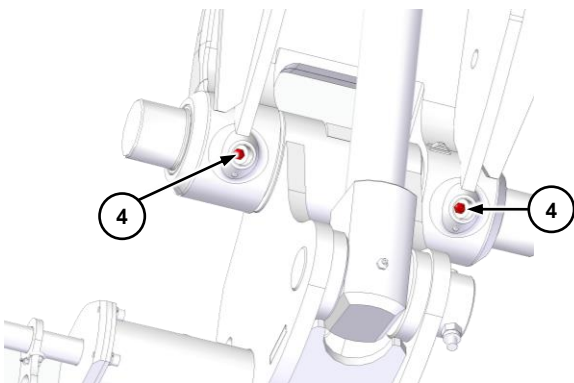

Lubricate the pin of quick-fit coupling ④ through the grease nipples.

Lubrication of slewing cylinder pins

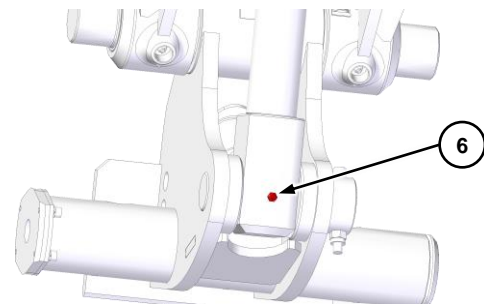
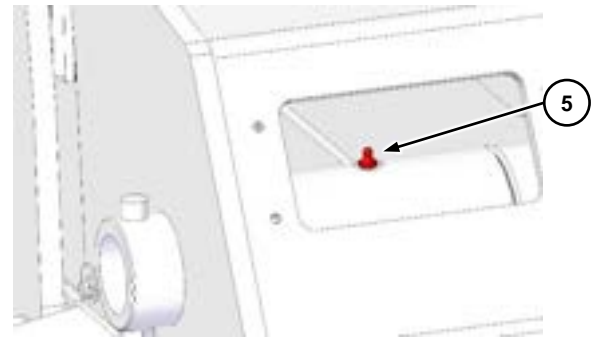

Lubricate pivots ⑤ and ⑥ of the swing cylinder using the grease nipples on the top and base of the swing cylinder: for the top grease nipple, remove the cover at the top of the last extension at the top of the telescopic boom.

Telescopic boom chains

Checking and lubrication

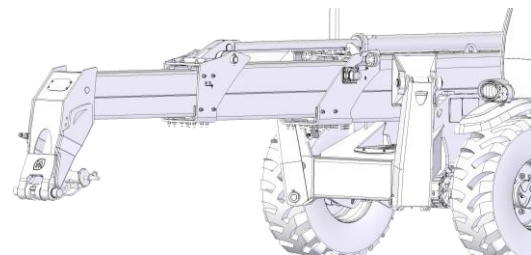

Park the vehicle in parking position and fully extend the telescopic boom horizontally.

Clean the chains and inspect carefully for signs of wear. Brush thoroughly to remove impurities. For maximum efficiency use a hard nylon brush and clean fuel.

Blow on the chains with compressed air. Lubricate with a brush soaked in oil. Wipe excess oil using a clean cloth.

Lubricate the pins of the rotation pulleys by injecting grease in the grease nipples provided for the purpose. Repeat the operations for all the outer chains and for all the pulleys of each extension of the telescopic boom.

Adjustment

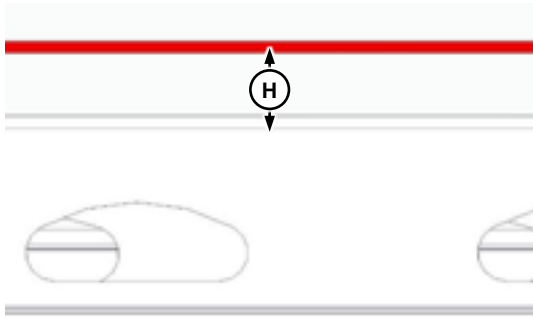

The services of an operator and an inspector are required to check the chains to see if they require adjustment.

Extend the telescopic boom in the horizontal position. Provide a rapid pulse to retract the boom and observe the oscillation of the chains. If, during oscillation, distance **H** from the upper surfaces of the extensions is less than 4 cm, the chain must be adjusted.

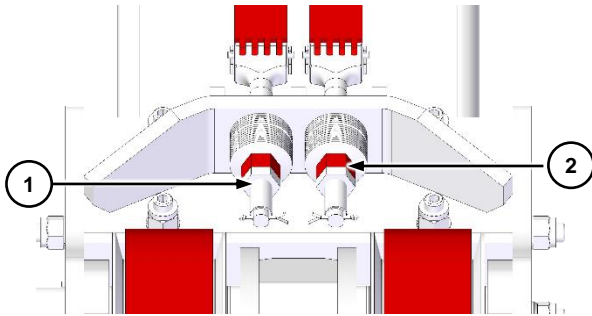

To adjust the chain, first slacken the chain tensioner lock nut ①, then turn nut ② clockwise to increase the chain tension, or anti-clockwise to decrease it.

Measure the distance between the chain axis and the surface of the boom. The reference values are:

- first extension: min. 3.34 in, max. 3.93 in (min. 85 mm, max. 100 mm);
- second extension: min. 2.56 in, max. 3.15 in (min. 65 mm, max. 80 mm);
- third extension: min. 2.75 in, max. 3.15 in (min. 70 mm, max. 80 mm).



WARNING

Take special care to avoid tightening the chains excessively. Breakage of a chain following incorrect adjustment without the dealer's assistance can lead to serious damage.

Checking for wear

To check the chains for wear, the main structural dimensions of the chains of each extension must be known. Take measurements of a new chain or contact your dealer for this information.

Position the vehicle on stabilisers.

Centre the turret and extend the telescopic boom completely in the horizontal position.

Take the measurements on chain sections with 15-18 links. Use the heads of the pins as reference, as shown.

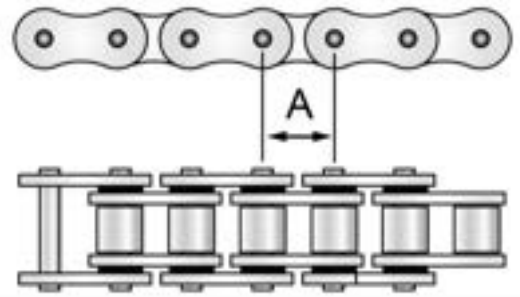

Fleyer chains	Pitch A (mm)	Pitch inch
AL4	12.7	0.5
AL5	15.87	0.6
AL6	19.05	0.7
AL8	25.4	1
AL10	31.75	1.2

NOTICE

If the lengthening of any of the sections is found to be greater than 2% the chain must be replaced.

Repeat the measurements for all the chains. For each chain, take a number of measurements on a number of sections to check non uniform wear. Always take the most worn area as reference.

For replacement of one or more chains, contact your dealer for assistance.

Stabilisers

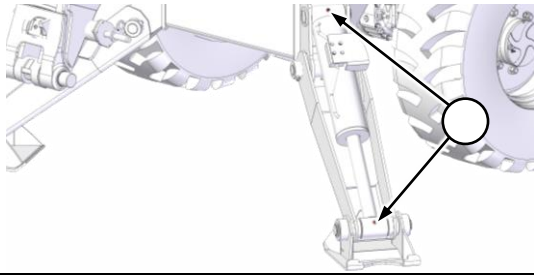

Set the vehicle in the parking position. Lower the stabilisers completely to the ground for easier access to the areas to be lubricated.

Lubricate all the rotation pins of the stabilisers, including the pins of the hydraulic cylinders. Lubricate by injecting grease in the grease nipples present on each pin. Wipe excess grease to prevent accumulation of dirt.

Operate the hydraulic movement of the stabilisers a number of times to distribute the grease uniformly. Make sure the stabiliser foot oscillates freely. Increase the lubrication frequency of the base support pin if necessary.

Batteries

The batteries are located in the central part of the vehicle chassis and protected by casing; to access them, fully raise the telescopic arm, lock it in position as described at the beginning of this section, and remove the casing.



DANGER

Batteries contain acid and corrosive substances and must be handled with care.

Wear protective equipment, such as gloves and goggles.

In case of contact with the eyes and/or skin, immediately rinse the affected body part and seek medical attention.



DANGER

Batteries contain highly polluting substances that must not be disposed of into the environment.

For used or damaged batteries, it is mandatory to follow the correct disposal procedures.



DANGER

Do not charge damaged batteries.

Do not place sources of sparks or open flames near batteries: high risk of flammability and explosion.

Do not charge batteries when hot.

- Handle batteries with care: do not overturn or tilt them to avoid leakage of the liquids they contain.
- Use a voltmeter or densimeter to check their status of charge.
- Do not generate sparks with the cable terminals during charge.
- Check that the plugs are correctly fitted and tightened.
- In conditions of low use resulting in their total discharge, they must be charged with a suitable instrument or replaced. Do not attempt to charge them with the car alternator.
- Before any work, activate the battery disconnect switch to cut off power supply to the vehicle.

NOTICE

For a quick restart of the vehicle in low battery voltage conditions, it is possible to use the two (positive and negative) poles located near the battery disconnect switch inside the engine compartment without directly accessing the battery compartment.

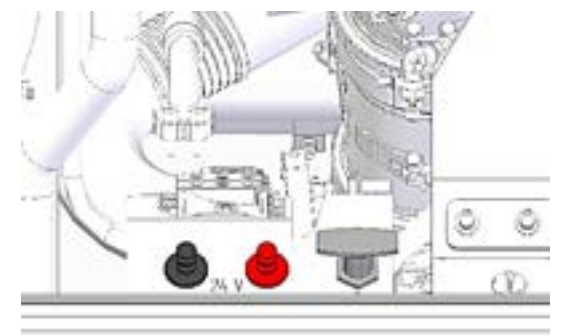

Windscreen washer liquid tank

Filling

Open the service compartment door, located on the left-hand side of the vehicle underneath the cab, by turning the handle (ensure that the cab door is closed in order to carry out this operation).

Open the windscreen washer liquid tank, located on the right-hand side of the service compartment, and unscrew the cap ① turning it anticlockwise. Fill the tank with windscreen washer liquid, leaving about 1 cm between the liquid level and the edge.

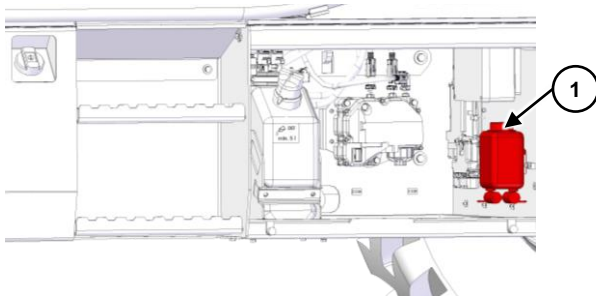

Screw the cap back on clockwise and tighten it.

Close the service compartment door turning and locking the handle.

FUSE SECTION

Relay/fuse box for the wagon line 84960.B

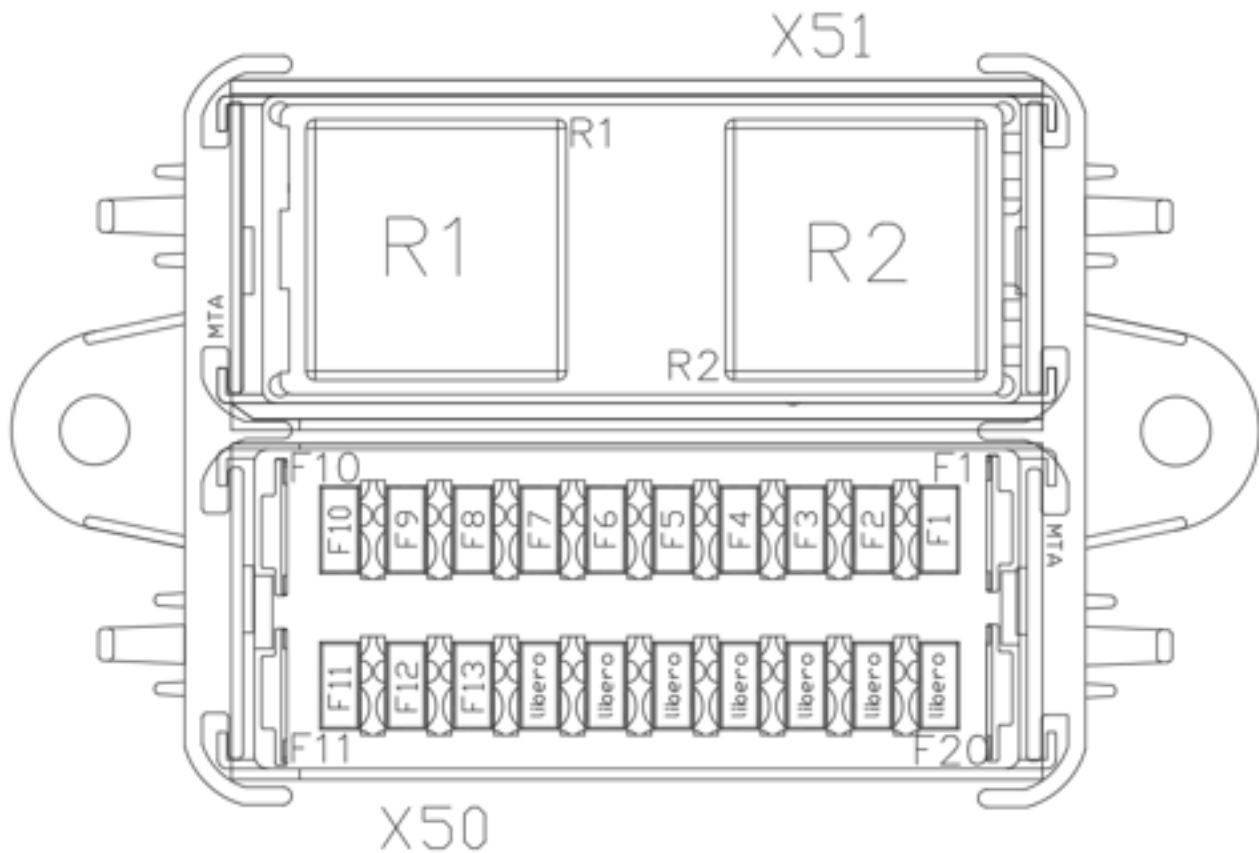

<i>MTA Modules</i>	<i>Component</i>	<i>Characteristics</i>	<i>Function</i>
X50 (20-way mini-fuse holder module)			
X50/F1	MINI	7.5A	+15 Front and cab side camera
X50/F2	MINI	5A	+15 Axle alignment proximity
X50/F3	MINI	5A	+15 Axle block proximity
X50/F4	MINI	7.5A	+15 Auxiliaries
X50/F5	MINI	5A	+15 Trinaries
X50/F6	MINI	5A	+15 Case back transducers
X50/F7	MINI	5A	+15 Stem transducers
X50/F8	MINI	5A	+15 Switch on Bosch Rexroth
X50/F9	MINI	5A	+15 X39/17 Deutz engine stage V
X50/F10	MINI	5A	+15 Alternator
X50/F11	MINI	5A	+15 Cassette preparation power supply

<i>MTA Modules</i>	<i>Component</i>	<i>Characteristics</i>	<i>Function</i>
X50/F12	MINI	5A	+15 Emergency mushroom signal for control units
X50/F13	MINI	20A	+30 Bosch Rexroth control unit power supply
X50/F14		-	-
X50/F15		-	-
X50/F16		-	-
X50/F17		-	-
X50/F18		-	-
X50/F19		-	-
X50/F20		-	-
X51 (2 maxi-relay module)			
X51/R1		24V	Emergency button pressed N.C. positive
X51/R2		24V	+15 Power from Key

Cabin internal wiring 81789.C

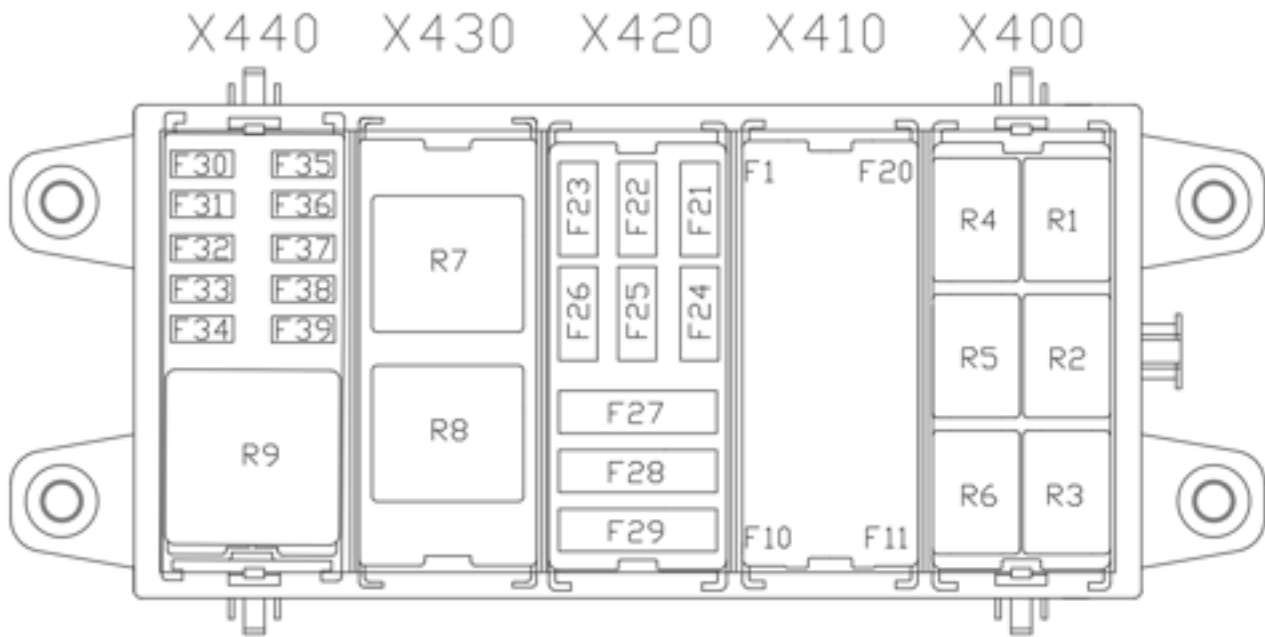

<i>MTA Modules</i>	<i>Component</i>	<i>Characteristics</i>	<i>Function</i>
X400 (Module carrying 6 microrelays)			
X400/R1		24V	Starting from Trackunit TU501-1
X400/R2		24V	Front wiper motor control
X400/R3		24V	Front wiper motor control
X400/R4		24V	Upper wiper return
X400/R5		24V	Rear wiper control
X400/R6		24V	Emergency button pressed N.C. pos.
X410 (20-way mini-fuse holder module)			
X410/F1	MINI	15A	Front wiper power supply
X410/F2	MINI	15A	Upper wiper power supply
X410/F3	MINI	15A	Rear wiper power supply
X410/F4	MINI	7.5A	+15 Front wiper intermittent
X410/F5	MINI	5A	+30 LED cabin lights
X410/F6	MINI	7.5A	Seat power supply
X410/F7	MINI	5A	+15 Cabin auxiliaries (USB & LIGHTS)
X410/F8	MINI	5A	+15 Emergency mushroom feedback
X410/F9	MINI	7.5A	+15 Switches, dials and buttons
X410/F10	MINI	7.5A	+15 Joystick Sauer Danfoss / +15 Joystick Power Grayhill

<i>MTA Modules</i>	<i>Component</i>	<i>Characteristics</i>	<i>Function</i>
X410/F11	MINI	10A	Common central output EXT tower
X410/F12	MINI	7.5A	+30 Cabin display power
X410/F13	MINI	7.5A	+30 Emergency indicator switch
X410/F14	MINI	7.5A	+30 Car radio
X410/F15	MINI	5A	+15 TUV power supply/+15 Basket guide transducer
X410/F16	MINI	7.5A	+30 Gateway interface power supply/ +30 Trackunit TU501-1 and Magni Diagnostics
X410/F17	MINI	7.5A	+15 Trackunit and Gateway
X410/F18	MINI	5A	+30 Trackunit Relay TU501-1
X410/F19	MINI	7.5A	Power supply from key +15 J1A
X410/F20	MINI	10A	Power supply from key +30 J1A
X420 (9-way fuse module (3maxi+6uni))			
X420/F21	ATO	25A	+15 Power VP1-VP4
X420/F22	ATO	25A	+15 Power VP2-VP5
X420/F23	ATO	25A	+30 Power VP3-VP6
X420/F24	ATO	7.5A	+15 Rear EXT control unit power supply. tower
X420/F25	ATO	10A	Outputs Power Supply EXT
X420/F26	ATO	7.5A	Sectioned power supply +15 optional
X420/F27	MAXI	40A	+30 direct from battery
X420/F28	MAXI	40A	Battery powered 15 key relay
X420/F29	MAXI	40A	Battery powered relay 15 isolated
X430 (Module carries 1 Maxirelay + 1 minirelay)			
X430/R7		24V	+15 Startup panel
X430/R8		24V	Emergency arrow warning light
X440 (Module carries 10 minifuses + 1 maxirelay)			
X440/F30	MINI	7.5A	+15 Sauer Danfoss distributor feed
X440/F31	MINI	5A	+15 Lifting transducer power supply
X440/F32	MINI	5A	+15 Compensation transducer power supply
X440/F33	MINI	7.5A	+15 Arm strain gauge supply
X440/F34	MINI	5A	+15 Turret inclinometer power supply
X440/F35	MINI	15A	+15 Car radio
X440/F36	MINI	10A	+15 Arm head functions

<i>MTA Modules</i>	<i>Component</i>	<i>Characteristics</i>	<i>Function</i>
X440/F37	MINI	5A	+15 Rotation encoder power supply
X440/F38	MINI	5A	+15 Rear video camera power supply/ Positive "15" predisposition
X440/F39	MINI	7.5A	+15 Light/wiper/horn switch power
X440/R9		24V	Emergency button pressed N.C. pos.

Smart power box 82305

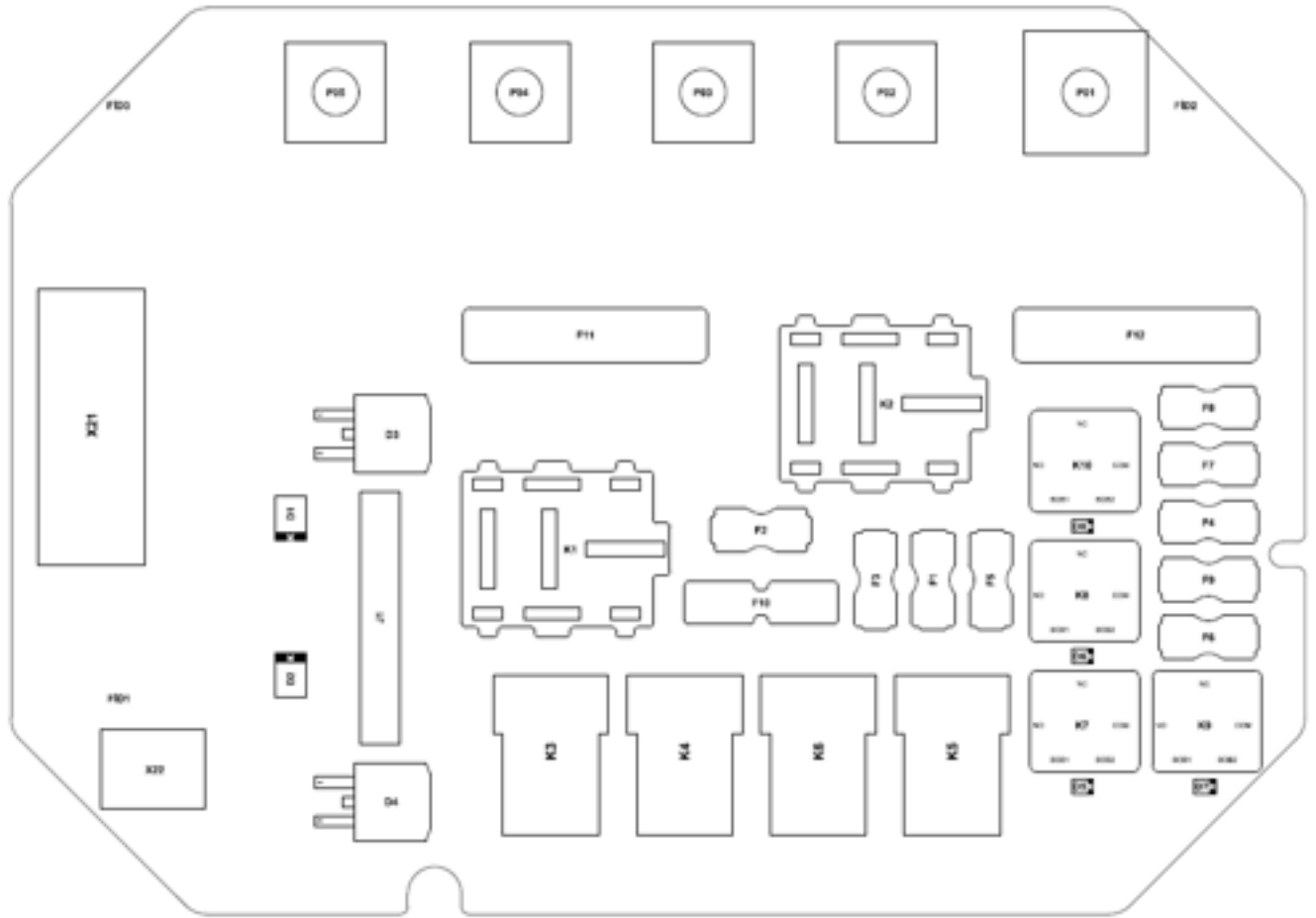

Fuse/relay	Component	Characteristics	Function
F1	MINI	5A	+15 UREA quality, level and temperature sensor
F2	MINI	15A	+15 Nox Sensor
F3	MINI	5A	+15 DC-DC Converter 24-12
F4	MINI	5A	+30 Emergency pump relay
F5	MINI	2A	+15 CAN device module (P.Box)
F6	MINI	5A	+30 Reverse relay
F7	MINI	5A	+30 A/C compressor relay
F8	MINI	2A	+30 CAN device module (P.Box)
F9	MINI	7.5A	+30 Brake light relay
F10	ATO	10A	+15 Diesel Pump
F11	MAXI	30A	+30 Bosch engine control unit power supply
F12	MAXI	30A	+30 Urea Heaters
K1		24V	Diesel pump positive
K2		24V	Urea heaters positive
K3		24V	Urea module power supply

<i>Fuse/relay</i>	<i>Component</i>	<i>Characteristics</i>	<i>Function</i>
K4		24V	Urea heater pressure line (tank delivery)
K5		24V	Urea heater suction line (injector delivery)
K6		24V	Urea heater return line (tank return)
K7		24V	Stop lights
K8		24V	Emergency pump relay
K9		24V	Reverse relay
K10		24V	A/C compressor relay

TROUBLESHOOTING

Using the emergency hydraulic pump (if any).

NOTICE

On models fitted with a manual emergency pump, in the event of a failure in the hydraulic system, the aerial platform or suspended load must be **expressly** recovered from the ground by working directly on the hydraulic distributor located at the rear of the vehicle.



ATTENTION

The following procedures are to be carried out only and exclusively in the event of technical faults: they are not in any way intended to bypass safety operation lockouts such as overload warnings, absence of shear pin when using the aerial platform, etc.



WARNING

In the event of unexamined problems or problems of a greater extent than those given in this manual, contact your local dealer or the Magni Telescopic Handlers Assistance Service.



DANGER

The following procedures **MUST** only be carried out by operators trained on how to use the vehicle correctly and the potential risks involved.

In order to safely recover the aerial platform or suspended loads, always proceed with alternating boom retraction and boom descent movements so as to stay within the working area shown in the load chart.

This procedure is the best possible procedure under ideal conditions. If, however, situations should arise in which there are obstacles (buildings, bridges, branches, etc.), the operator can change this procedure according to his experience and compatible with the context in which he finds himself, but at his own risk.



DANGER

In conditions of ascertained danger or operational incapacity, first contact the local emergency services.



ATTENTION

Two operators described below require the presence of two operators on the ground.

In the event the vehicle has shut down (no engine power and failure of the electrical system), the hydraulic circuit must be activated manually: after taking the rear cover off the vehicle and pulling out the actuation lever located inside the chassis ①, the first operator on the ground must insert it in its seat, as illustrated below ②, and start pumping in order to pressurise the circuit ③

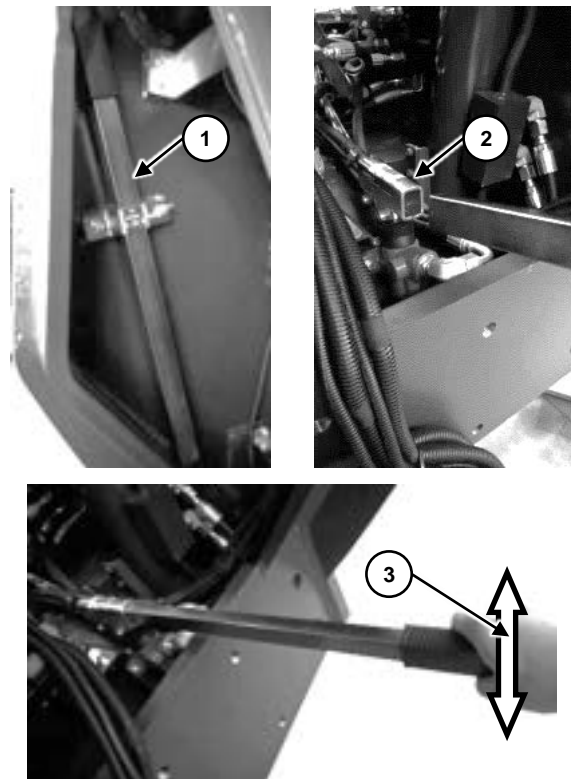

While continuing to keep the circuit under pressure ③ under pressure, a second operator must use 9 mm spanners on the spools of the hydraulic distributor, as shown in the diagram below.

In order to enable the hydraulic flow in the distributor, turn the nut ④ of the first spool on the left and hold it in position; with a second spanner, engage the nut on the spool of the fifth element ⑤, starting from the left, which operates the boom extension return control; lastly, when the boom is closed, act on the third spool again from the left, engaging and turning the nut ⑥ that operates the boom descent control.

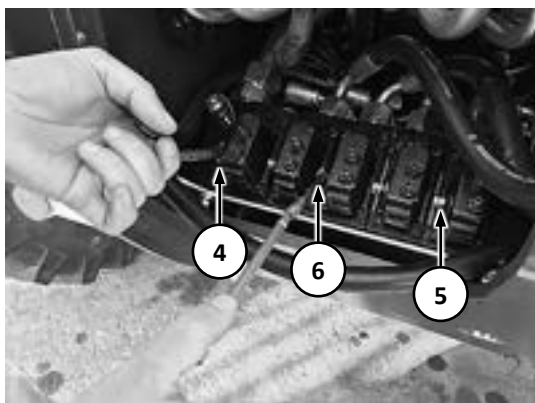

NOTICE

Given the emergency condition, the return and lowering movements of the telescopic boom are particularly slow.

Once the procedure for returning the aerial platform or suspended load to the ground is complete, take the vehicle out of service and have it checked by an authorised assistance centre.

DIAGNOSING PROBLEMS

Engine – does not switch on or switching on is difficult (no fumes at exhaust)

Cause	Solution
No fuel in tank	Refuel.
Ignition switch defective	Check the opening and closing of the electric connection.
Fuel filter clogged	Bleed the water separator or replace the filter.
Fuel priming pump defective	Check to make sure the pump provides the flow rate suitable for the high pressure pump. Check the electrical connections.
Air in the fuel	Check the absence of air returning to the circuit.
Fuel dirty or non conforming	SWITCH THE ENGINE OFF. Replace the fuel filters. Run the engine with correct fuel.
Suction or discharge system obstructed	Visually inspect the suction and discharge, and remove any obstructions present. Replace the air filter if necessary.
Fuel return line blocked	Check to make sure the line is clear and connected to the upper part of the tank.
Fault in one or more injectors	Check the electrical connections.
ECU or sensors fault	Check the electrical connections.

Engine – does not turn when started up or moves slowly

Cause	Solution
Electrical circuit elements loose or worn	Clean and carry out the necessary maintenance.
Battery flat	Check the voltage using a multimeter. Check the working of the alternator.
Solenoid or starter motor fault	Replace the starter motor.
Starter motor working but the engine does not rotate	Remove the starter motor and check the state of the gears and spring.

Engine – starts up but switches off immediately

Cause	Solution
No fuel in tank	Refuel.
Starter motor charged	Check the presence of external loads due to faulty auxiliaries.

Cause	Solution
Suction or discharge system obstructed	Visually inspect the suction and discharge, and remove any obstructions present. Replace the air filter if necessary.
Fuel priming pump defective	Check to make sure the pump provides the flow rate suitable for the high pressure pump. Check the electrical connections.
Fuel frozen	Use fuels suitable for low temperatures.
Air in the fuel	Check the absence of air returning to the circuit.
Fuel dirty or non conforming	SWITCH THE ENGINE OFF. Replace the fuel filters. Run the engine with correct fuel.
Fuel supply obstructed	Check for blockage along the line. Check the state of the filters and replace if necessary.
Fuel return line blocked	Check to make sure the line is clear and connected to the upper part of the tank.
ECU or sensors fault	Check the electrical connections.

Engine – irregular operation

Cause	Solution
Engine cold, or coolant temperature sensor fault	Check the sensor electrical connection. Check the working of the sensor.
Leakage in fuel circuit	Replace the defective connections. DO NOT try to carry out repairs.
Air in the fuel	Check the absence of air returning to the circuit.
Fuel priming pump defective	Check to make sure the pump provides the flow rate suitable for the high pressure pump. Check the electrical connections.
Fuel supply obstructed	Check for blockage along the line. Check the state of the filters and replace if necessary.
Fuel dirty or non conforming	SWITCH THE ENGINE OFF. Replace the fuel filters. Run the engine with correct fuel.
Incorrect adjustment of valve play	Correct the adjustment.
Compression not good in one or more cylinders	Check the compression ratio.
ECU or sensors fault	Check the electrical connections.

Engine – excessive noise

Cause	Solution
Slipping of transmission belt, tension insufficient or excessive	Check the belt tensioner and inspect the belt. Make sure the pulley rotation is not hindered.
Coolant temperature sensor fault	Check the sensor electrical connection. Check the working of the sensor.
Fuel dirty or non conforming	SWITCH THE ENGINE OFF. Replace the fuel filters. Run the engine with correct fuel.
Incorrect adjustment of valve play	Correct the adjustment. Make sure the rod and equaliser mechanism is not damaged or worn.
Noise coming from engine block	Contact your dealer urgently.

Engine – reduced power

Cause	Solution
No fuel in tank	Refuel.
Oil level not correct	Check the level.
Engine overload	Check the presence of overloads due to faulty auxiliary parts.
Fuel dirty or non conforming	SWITCH THE ENGINE OFF. Replace the fuel filters. Run the engine with correct fuel.
Fault in turbocompressor	Contact your dealer.
Leakage in fuel circuit	Replace the defective connections. DO NOT try to carry out repairs.
Fuel supply obstructed	Check for blockage along the line. Check the state of the filters and replace if necessary.
Air in the fuel	Check the absence of air returning to the circuit.
Fuel priming pump defective	Check to make sure the pump provides the flow rate suitable for the high pressure pump. Check the electrical connections.
Suction or discharge system obstructed	Visually inspect the suction and discharge, and remove any obstructions present. Replace the air filter if necessary.
Fault in one or more injectors	Check the electrical connections.
Leaks in manifolds or in turbocompressor	Check and correct leaks in the manifolds.
Too many sealing washers installed under the injectors	Remove the excess sealing washers.
Incorrect adjustment of valve play	Correct the adjustment.
Compression not good in one or more cylinders	Check the compression ratio.

Engine – does not reach the maximum rpm

Cause	Solution
Speedometer defective	Check the engine speed using a manual speedometer. Correct if necessary.
Engine overload	Check the presence of overloads due to faulty auxiliary parts.
Fuel dirty or non conforming	SWITCH THE ENGINE OFF. Replace the fuel filters. Run the engine with correct fuel.
Wastegate valve actuator diaphragm cracked	Repair or replace the turbocompressor.
Leakage in fuel circuit	Replace the defective connections. DO NOT try to carry out repairs.
Fuel supply obstructed	Check for blockage along the line. Check the state of the filters and replace if necessary.
Fuel priming pump defective	Check to make sure the pump provides the flow rate suitable for the high pressure pump. Check the electrical connections.
Fault in one or more injectors	Check the electrical connections.
Fuel high pressure pump fault	Contact your dealer.

Engine – excessive vibrations

Cause	Solution
Oil level excessive	Check the level.
Fan damaged or auxiliaries fault	Replace the defective components.
Fan hub damaged	Check and replace the hub.
Engine supports loose or damaged	Tighten the loose supports and replace those that are damaged.
Incorrect adjustment of valve play	Correct the adjustment.
Compression not good in one or more cylinders	Check the compression ratio.
Alternator bearing worn	Check/replace the alternator.

Engine – black fumes at the exhaust

Cause	Solution
Suction or discharge system obstructed	Visually inspect the suction and discharge, and remove any obstructions present. Replace the air filter if necessary.
Leaks between the turbocompressor and suction manifold	Inspect and repair the leaks.
Intercooler defective	Check the radiator mass.
Leaks from discharge manifolds or from turbocompressor	Repair the leaks from the gaskets. Check for cracks in the connections.
Wastegate valve fault	Replace the valve.
Turbocompressor fault	Replace.
Fault in one or more injectors	Check the electrical connections.
Compression not good in one or more cylinders, fumes with load mainly at average and low speeds	Contact your dealer.

Engine - white fumes at the exhaust

Cause	Solution
Fuel dirty or non conforming	SWITCH THE ENGINE OFF. Replace the fuel filters. Run the engine with correct fuel.
Oil level not correct	Check the level.
Diesel and hydraulic fluid in engine casing	If the oil is contaminated, check the gaskets at the power take-offs. Drain oil, clean and refill with fresh oil.
Leaks from seals in the valve seats – evident after long periods at minimum speed followed by sudden acceleration	Contact your dealer.
Fault in one or more injectors	Check the electrical connections.
Piston belts not sealed – blue fumes at all speeds	Contact your dealer.

Fuel – excessive consumption

Cause	Solution
Additional loads on the engine	Check/repair the auxiliaries and equipment of the telehandler.

Cause	Solution
Fuel leaks	Check for leaks near the tank, fuel line, filters and priming pump. DO NOT try to repair the defective piping.
Control unit defective	Contact your dealer.
Fault in one or more injectors	Check the electrical connections.
Incorrect adjustment of valve play	Correct the adjustment.

Fuel/oil – leaks from the drainage

Cause	Solution
Turbocompressor lubrication line obstructed	Check and clean the piping.
Leaks from discharge manifolds or from turbocompressor	Repair the leaks from the gaskets. Check for cracks in the connections.
Leaks from the valve guides	Contact your dealer.
Control unit defective	Contact your dealer.
Fault in one or more injectors	Check the electrical connections.

Lubricant – excessive consumption

Cause	Solution
Oil leaks	Check the engine for leaks.
Lubricant specifications unsuitable	Make sure a suitable lubricant is used. Check contamination by fuel.
Leaks in cooling system	Check for the presence of lubricating oil in the coolant.
Leaks from turbocompressor in the suction or discharge system	Check for leaks.
Leaks from the valve guides	Contact your dealer.
Cylinders worn or damaged	Contact your dealer.

Lubricant - contamination

Cause	Solution
Oily deposit in lubricant	Change the oil and filters. If operating in particularly heavy duty conditions, increase the maintenance frequency. Make sure a suitable lubricant is used.
Fuel in lubricant oil, engine temperature very low	Avoid leaving the engine running at low speed for too long.

Lubricant - pressure excessively low

Cause	Solution
Oil level not correct	Check the level.
Lubricant specifications unsuitable	Make sure a suitable lubricant is used. Check contamination by fuel.
Pressure gauge fault	Check for correct operation.
Oil filter clogged	Change the oil and filters. If operating in particularly heavy duty conditions, increase the maintenance frequency. Make sure a suitable lubricant is used.
The oil priming pump pressure limiter valve is blocked in the open position	Contact your dealer.
The oil pump pressure limiter valve is blocked in the open position	Contact your dealer.
Oil pump worn	Contact your dealer.

Lubricant – excessive pressure

Cause	Solution
Lubricant specifications unsuitable	Make sure a suitable lubricant is used. Check contamination by fuel.
Pressure gauge fault	Check for correct operation.
The oil pump pressure limiter valve is blocked in the closed position	Contact your dealer.

Coolant - leaks

Cause	Solution
Coolant level not correct	Check the level.
Liquid leaks from radiator	Check the radiator, hoses and piping for leaks.
Liquid leaks from engine	Check the engine for leaks from gaskets, pipes or unions. Make sure all the clamps are tightened properly and in good condition.
Leaks from the head gasket	Contact your dealer.
Engine head cracked or shows porosity	Contact your dealer.
Leaks from lubricant passages in the base	Contact your dealer.

Coolant - overheating

Cause	Solution
Coolant level not correct (low)	Check the level.
Radiator grille obstructed	Clean the radiator grille.
Air flow to radiator insufficient or obstructed	Check/repair the fan.
Belt tension insufficient	Check the tension.
Radiator pipe crushed, obstructed or cracked	Check/replace the defective pipe.
Oil level not correct (high)	Check the level.
Radiator cap defective	Replace the radiator cap.
Excessive concentration of antifreeze	Drain part of the circuit and fill with distilled water.
Temperature sensor defective	Check the accuracy of the sensor.
Thermostat faulty or missing	Check/replace the thermostat.
Coolant pump faulty	Check/replace the pump.
Passage of liquid through the radiator, head or engine block obstructed	Wash the plant with distilled water and fill with fresh coolant.

Coolant – not at required temperature

Cause	Solution
Temperature sensor defective	Check the accuracy of the sensor.
Thermostat defective (blocked open)	Check/replace the thermostat.
Liquid not circulating near the temperature sensor	Check/clean the liquid passages.

VEHICLE STORAGE

Leaving the vehicle unused for long periods

If the vehicle is to be left unused for more than 30 days, carry out certain operations to keep it in good condition and maintain a high level of service.

Leaving the vehicle unused for less than 12 months

Park the vehicle in a well ventilated area, free of humidity and protected from atmospheric agents. Make sure the environmental temperature in the area does not fall below 50°F (-10°C).

Clean the vehicle thoroughly. Remove all traces of rust or corrosion. Touch up the paint layer in the areas concerned.

Change the engine oil and the filter if the oil is more than 12 months old or after 300 hours of service after the last change.

Charge the batteries. Check the level of electrolyte before and after charging. Disconnect the negative pole after the charging.

Check the coolant level and top up if necessary.

Check the pressure in the AdBlue® circuit pressure accumulator.

Drain water from the fuel prefilter with water/fuel separator.

Close the drainage pipe and the air intake in the filter casing with rags soaked in oil.

Loosen the belt tensioner device in the transmission belt. Do not dismantle the transmission belt completely.

Leaving the vehicle unused for less than 36 months

If the vehicle is to be left unused for more than 12 months and less than 36 months, certain protective measures must be adopted in addition to those required for leaving the vehicle unused for less than 12 months.

Fill the fuel tank completely. Run the engine for 15 – 30 minutes at not more than 900 rpm.

Disconnect the suction manifolds from the top of the engine. Press the start button present on each engine briefly and at the same time pour about 15 cc of oil in each cylinder.

Pour about 5cc of oil in the volumetric compressor on the suction side.

Refit all the components and tighten the fixing screws applying the correct tightening torque.

Reusing the vehicle

Clean the fuel tank. Refuel.

Replace the fuel prefilter and filter.

Check the coolant level. If topping up is necessary, take a sample of the liquid and check the composition. Add distilled water or pure liquid to adjust the composition.

Check the battery charge. Charge if necessary. Check the level of electrolyte before and after charging. Again connect the negative pole to the batteries. Check the electrical system to make sure it is working correctly.

Check the condition of the transmission belt. Replace if necessary. Restore the working of the belt tensioner device.

Start up the engine and let it run for 15 – 30 minutes at not more than 900 rpm. Keep the oil pressure, water temperature and oil temperature indicators under observation.

Check the oil level in the axles, in the wheel reduction gears and in the gearbox.

Dismantling and disposal of the vehicle

By the time the vehicle is taken out of service, the reference standards will have changed. The procedures for dismantling and scrapping the vehicle vary according to the regulatory standards in force in the country in which it is used. For information regarding dismantling and scrapping the vehicle, contact your dealer for updates regarding the directives in force.



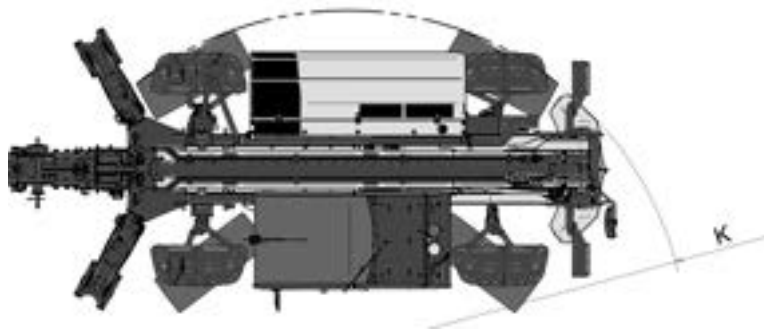
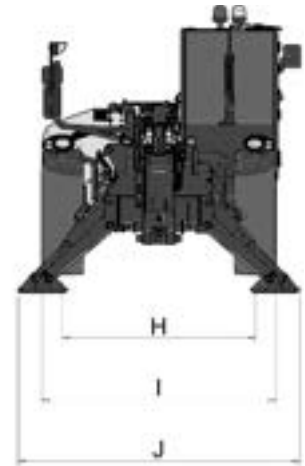
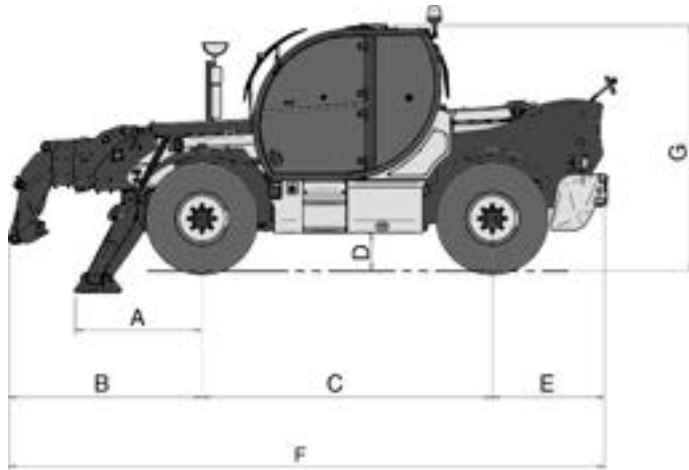

DIMENSIONS



	TH 4,5.15 / TH 4,5.15P	TH 4,5.19 / TH 4,5.19P
A	53.15" (1350 mm)	53.15" (1350 mm)
B	81.42" (2068 mm)	81.02" (2058 mm)
C	121.61" (3089 mm)	121.61" (3089 mm)
D	15.75" (400 mm)	15.75" (400 mm)
E	46.97" (1193 mm)	46.97" (1193 mm)
F	250" (6350 mm)	250" (6350 mm)
G	102.91" (2614 mm)	102.91" (2614 mm)
H	80.71" (2050 mm)	80.71" (2050 mm)
I	98.03" (2490 mm)	98.03" (2490 mm)
J	118.11" (3000 mm)	118.11" (3000 mm)
K	R 142.52" (3620 mm)	R 142.52" (3620 mm)

TECHNICAL DATA

Performances

Model	TH 4,5.15		TH 4,5.19	
	55.4 kW -D5/D -D5/A	74.4 kW -D7/D -D7/A	55.4 kW -D5/D -D5/A	74.4 kW -D7/D -D7/A
MAXIMUM SPEED	16 mph 25 Km/h	21 mph 35 Km/h	16 mph 25 Km/h	21 mph 35 Km/h
STANDARD LIFTING HEIGHT (*)	49.2 ft (15 m)		62.3 ft (19 m)	
GRADEABILITY	59%		58%	
MAXIMUM RATED CAPACITY (**)	10,000 lb (4.500 kg)		10,000 lb (4.500 kg)	
MASS IN RUNNING ORDER (without accessory)	26,900 lb (12.200 Kg)		28,000 lb (12.700 Kg)	
MASS DISTRIBUTION ON FRONT AXLE	11,700 lb (5.300 Kg)		12,350 lb (5.600 Kg)	
MASS DISTRIBUTION ON REAR AXLE	15,200 lb (6.900 Kg)		7.100 Kg (15,650 lb)	
MAXIMUM GROUND LOAD ON OUTRIGGERS 	22,000 lb (10.000 kg)		22,000 lb (10.000 kg)	
MAXIMUM GROUND PRESSURE ON STABILISERS 	9 kgf / cm ² (128 psi)		9 kgf / cm ² (128 psi)	
MAXIMUM GROUND LOAD ON TYRES (***) 	17,200 lb (7,800 kg)		17,200 lb (7,800 kg)	
MAXIMUM GROUND PRESSURE ON TYRES (***) 	5,5 kg / cm ² (78.23 psi)		5,5 kgf / cm ² (78.23 psi)	

(*) **With interchangeable fork carriage equipment**

(**) **To find out the actual load capacity according to the conditions of use of the vehicle, refer to the specific use and maintenance manual of the connected equipment.**

(***) **data referring to tyres supplied as standard by the manufacturer and with vehicle at maximum load**

ENGINE: DEUTZ (STAGE IIIA / STAGE V)

<i>Model</i>	TH 4,5.15 / TH 4,5.19	
	55.4 kW -D5/D -D5/A	74.4 kW -D7/D -D7/A
<i>ENGINE SERIES</i>	DEUTZ TCD 3.6 L4 /A Stage IIIA (Tier III)– /D Stage V	
<i>THERMODYNAMIC CYCLE</i>	Diesel 4 strokes	
<i>ARCHITECTURE</i>	4 in-line cylinders	
<i>VALVES</i>	16 valves	
<i>POWER SUPPLY</i>	Turbocompressed with intercooler	
<i>DISPLACEMENT</i>	3,620 cc	
<i>COOLING</i>	With liquid	
<i>MAXIMUM POWER</i>	55.4 kW (74.3 HP) at 2200 rpm	74.4 kW (99.8 HP) at 2200 rpm
<i>MAXIMUM TORQUE</i>	405 Nm at 1300 rpm	410 Nm at 1600 rpm
<i>RATED SPEED AT MINIMUM</i>	900 rpm	900 rpm

Transmission

<i>TH Model</i>	TH 4,5.15 / TH 4,5.19 55.4 kW (-D5/D, -D5/A) — 74.4 kW (-D7/D, -D7/A)
<i>TYPE</i>	Hydrostatic with Rexroth electronic control
<i>MAXIMUM PRESSURE</i>	480 bar
<i>NO. OF FORWARD GEARS</i>	2
<i>NO. OF REVERSE GEARS</i>	2
<i>REVERSE GEAR</i>	Electro-hydraulic

Hydraulic System

<i>Model</i>	TH 4,5.15 / TH 4,5.19 55.4 kW (-D5/D, -D5/A) — 74.4 kW (-D7/D, -D7/A)
<i>PUMP</i>	with variable displacement pistons
<i>FLOW RATE at 2200 rpm</i>	95 l/min
<i>PRESSURE</i>	350 bar

Electrical System

Model	TH 4,5.15 / TH 4,5.19 55.4 kW (-D5/D, -D5/A) — 74.4 kW (-D7/D, -D7/A)
<i>MASS</i>	Negative
<i>BATTERIES</i>	2 12 V – 150 A batteries
<i>ALTERNATOR</i>	28V – 80A
<i>START-UP</i>	24 V

Braking System

Model	TH 4,5.15 / TH 4,5.19 55.4 kW (-D5/D, -D5/A) — 74.4 kW (-D7/D, -D7/A)
<i>TYPE</i>	Multiple disc in oil bath
<i>SERVICE BRAKE</i>	Pedal-operated servo-assisted, action on front and rear wheels
<i>PARKING BRAKE</i>	Hydraulic negative action on front axle

Axles

Model	TH 4,5.15 / TH 4,5.19 55.4 kW (-D5/D, -D5/A) — 74.4 kW (-D7/D, -D7/A)
<i>FRONT AXLE</i>	Steering and levelling
<i>REAR AXLE</i>	Steering and tilting (locking)
<i>WHEEL HUB REDUCERS</i>	Epicyclic
<i>TYRES</i>	18 R 22.5

Tyres

Measurement	Characteristics	Make	Inflation pressure	Rim size
18 R 22.5 (445/65 R 22,5)	AGP23 169F	Aeolus	8.30 bar (0.83 Mpa) (120 psi)	14.00 x 22.5

Environmental data

Parameter		Values	
OPERATING TEMPERATURE		-4°F to +113°F (-20°C to +45°C)	
STORAGE TEMPERATURE		-13°F to +122°F (-25°C to +50°C)	
HUMIDITY		from 20% to 95%	
ALTITUDE		< 8200 ft (< 2500 m)	
ENVIRONMENTAL NOISE EMISSION - SOUND PRESSURE VALUES IN THE CAB HAND-ARM VIBRATION VALUES			
Emitted sound power level (guaranteed) In compliance with: Directive 2000/14/EC - L _{wa}	TH 4,5.15-D5/D (TH4,5.15) – 55.4 kW TH 4,5.19-D5/D (TH4,5.19) – 55.4 kW	104 dB	
	TH 4,5.15-D7/D (TH4,5.15 P) – 74.4 kW TH 4,5.19-D7/D (TH4,5.19 P) – 74.4 kW	106 dB	
Sound pressure level to the operator’s ear ^[L_{SEP}] in compliance with: UNI EN ISO 11201	TH 4,5.15-D5/D (TH4,5.15) – 55.4 kW TH 4,5.19-D5/D (TH4,5.19) – 55.4 kW	78 dB (*)	
	TH 4,5.15-D7/D (TH4,5.15 P) – 74.4 kW TH 4,5.19-D7/D (TH4,5.19 P) – 74.4 kW	/ (***)	
Operator’s vibration level ^[L_{SEP}] in compliance with: UNI EN ISO 13059	Body [UNI ISO 2631-1]	TH 4,5.15-D5/D (TH4,5.15) – 55.4 kW TH 4,5.19-D5/D (TH4,5.19) – 55.4 kW	0.55 m/s ² (**)
		TH 4,5.15-D7/D (TH4,5.15 P) – 74.4 kW TH 4,5.19-D7/D (TH4,5.19 P) – 74.4 kW	/ (***)
	Hand-arm [UNI EN ISO 5349-1]	TH 4,5.15-D5/D (TH4,5.15) – 55.4 kW TH 4,5.19-D5/D (TH4,5.19) – 55.4 kW	0.61 m/s ² (**)
		TH 4,5.15-D7/D (TH4,5.15 P) – 74.4 kW TH 4,5.19-D7/D (TH4,5.19 P) – 74.4 kW	/ (***)

(*) ± 1.0 dB uncertainty for Class I equipment according to the ISO 11200 family standard

(**) 0.5a uncertainty for Class I equipment according to BS EN 12096

(***) data not available at the date of issue of this use and maintenance manual

REFERENCE INFORMATION

Telehandler serial number:

Engine serial number:

Year of production:

Notes:

.....

.....

.....

.....

Dealer name Magni Telescopic Handlers S.r.l.:

Dealer's address:

Attach your business card or enter your dealer information here

Reference person of sales department (Name)

(Telephone)

(E-mail)

Reference person for rental (Name)

(Telephone)

(E-mail)

Service Contact (Name)

(Telephone)

(E-mail)

Contact for spare parts (Name)

(Telephone)

(E-mail)

REGISTER OF CHANGE OF OWNERSHIP

Registration of change of ownership

on _____

The ownership of the vehicle identified in this Register has been transferred to:

Company _____

with headquarters in street/no. _____

Postcode/City/Town _____, Province _____

represented by Mr. _____

It is hereby declared that, at the time of preparation of this document, the technical, dimensional and functional features of the vehicle described in this Register are in line with those indicated at the beginning by the Manufacturer and that changes, if any, have been recorded.

Furthermore, we declare that the transfer has been reported to the relevant Bodies (local INAIL).

The Dealer _____

The buyer _____

Registration of change of ownership

on _____

The ownership of the vehicle identified in this Register has been transferred to:

Company _____

with headquarters in street/no. _____

Postcode/City/Town _____, Province _____

represented by Mr. _____

It is hereby declared that, at the time of preparation of this document, the technical, dimensional and functional features of the vehicle described in this Register are in line with those indicated at the beginning by the Manufacturer and that changes, if any, have been recorded.

Furthermore, we declare that the transfer has been reported to the relevant Bodies (local INAIL).

The Dealer _____

The buyer _____

Registration of change of ownership

on _____

The ownership of the vehicle identified in this Register has been transferred to:

Company _____

with headquarters in street/no. _____

Postcode/City/Town _____, Province _____

represented by Mr. _____

It is hereby declared that, at the time of preparation of this document, the technical, dimensional and functional features of the vehicle described in this Register are in line with those indicated at the beginning by the Manufacturer and that changes, if any, have been recorded.

Furthermore, we declare that the transfer has been reported to the relevant Bodies (local INAIL).

The Dealer _____

The buyer _____

Registration of change of ownership

on _____

The ownership of the vehicle identified in this Register has been transferred to:

Company _____

with headquarters in street/no. _____

Postcode/City/Town _____, Province _____

represented by Mr. _____

It is hereby declared that, at the time of preparation of this document, the technical, dimensional and functional features of the vehicle described in this Register are in line with those indicated at the beginning by the Manufacturer and that changes, if any, have been recorded.

Furthermore, we declare that the transfer has been reported to the relevant Bodies (local INAIL).

The Dealer _____

The buyer _____